

ROBOTICS

Product manual

DressPack IRB 8700



Trace back information:
Workspace 24D version a11
Checked in 2024-12-20
Skribenta version 5.6.018

Product manual
DressPack IRB 8700
IRC5, OmniCore

Document ID: 3HAC055802-001

Revision: H

The information in this manual is subject to change without notice and should not be construed as a commitment by ABB. ABB assumes no responsibility for any errors that may appear in this manual.

Except as may be expressly stated anywhere in this manual, nothing herein shall be construed as any kind of guarantee or warranty by ABB for losses, damage to persons or property, fitness for a specific purpose or the like.

In no event shall ABB be liable for incidental or consequential damages arising from use of this manual and products described herein.

This manual and parts thereof must not be reproduced or copied without ABB's written permission.

Keep for future reference.

Additional copies of this manual may be obtained from ABB.

Original instructions.

© Copyright 2015-2024 ABB. All rights reserved.
Specifications subject to change without notice.

Table of contents

Overview of this manual	7
Product documentation	9
How to read the product manual	11
Product name principles	12
1 Safety	15
1.1 Safety information	15
1.1.1 Limitation of liability	15
1.1.2 Requirements on personnel	16
1.2 Safety signals and symbols	17
1.2.1 Safety signals in the manual	17
1.2.2 Safety symbols on manipulator labels	18
1.3 Robot stopping functions	24
1.4 Safety during installation and commissioning	25
1.5 Safety during operation	27
1.6 Safety during maintenance and repair	28
1.6.1 Safety during maintenance and repair	28
1.7 Safety during troubleshooting	31
1.8 Safety during decommissioning	32
2 Installation	33
2.1 Introduction	33
2.2 Overview	34
2.3 Fitting the process turning disc	35
2.4 DressPack cable package	39
2.4.1 Overview	39
2.4.2 Installation of IRBDP MH LI	40
2.4.2.1 Fitting the cable package IRBDP MH LI	40
2.4.3 Installation of IRBDP MH3 UI	49
2.4.3.1 Fitting attachments of the IRBDP MH3 UI	49
2.4.3.2 Fitting the cable package IRBDP MH3 UI	54
2.4.4 Installation of IRBDP SW6 LI, LeanID	60
2.4.4.1 Fitting attachments of the IRBDP SW6 LI, Lean ID	60
2.4.4.2 Fitting the cable package IRBDP SW6 LI, Lean ID	65
2.4.5 Installation of IRBDP MH6 UI and IRBDP SW6 UI, LeanID	74
2.4.5.1 Fitting attachments of the IRBDP MH6 UI and IRBDP SW6 UI, Lean ID ...	74
2.4.5.2 Fitting the cable packages IRBDP MH6 UI and IRBDP SW6 UI, Lean ID ..	80
2.5 Inspection, DressPack lower arm	89
2.6 Inspection, DressPack upper arm	90
2.7 DressPack adjustments	92
2.7.1 Inspection during programming and test-running	92
2.8 DressPack arm load parameters	94
2.8.1 DressPack - arm load parameters and LoadId	94
2.9 DressPack floor	96
2.9.1 Installation of DressPack floor	96
2.9.2 Inspection, DressPack floor	100
2.10 Water & Air unit	101
2.10.1 Installation of Water and air unit	101
2.10.2 Return water flow control	109
2.10.3 Return water flow switch setting	110
2.10.4 Setting of air pressure switch (only applicable to type S)	112
2.10.5 Setting of electrical proportional valve (option)	114
2.11 Test run after installation, maintenance, or repair	116
3 Maintenance	117
3.1 Introduction	117

Table of contents

3.2	Maintenance schedule and component life	118
3.2.1	Maintenance schedule	118
3.3	Inspection activities DressPack	120
3.3.1	Preventive inspection of all cables, DressPack	120
3.3.2	Preventive inspection, DressPack	122
3.3.3	Preventive inspection of Water and air unit	126
3.4	Cleaning activities	128
3.4.1	Cleaning, DressPack upper arm	128
3.4.2	Cleaning, Water and air unit	129
3.4.3	Cleaning the Fan unit	131
3.4.4	Cleaning the Weld timer cooling fins	133
4	Repair	135
4.1	Introduction	135
4.2	DressPack cable package	136
4.2.1	Addition of functional ground (Paramulti)	136
4.2.2	Replacing the cable package IRBDP MH3 UI	137
4.2.3	Replacing the cable package IRBDP MH LI	145
4.2.4	Replacing the cable package IRBDP SW6 LI LeanID	158
4.2.5	Replacing the cable packages IRBDP SW6 UI and IRBDP MH6 UI LeanID	171
4.2.6	Replacing the protection hose IRBDP SW6 UI and IRBDP MH6 UI LeanID	183
4.3	Water & Air unit	193
4.3.1	Replacement of Air supply circuit	193
4.3.2	Replacement of Water-in circuit	196
4.3.3	Replacement of Water-return circuit	199
4.3.4	Replacement of Air filter element	202
5	Decommissioning	205
5.1	Environmental information	205
6	Reference information	207
6.1	Introduction	207
6.2	Unit conversion	208
6.3	Screw joints	209
6.4	Weight specifications	212
6.5	Toolkits, DressPack	213
6.6	Lifting accessories and lifting instructions	215
7	Spare parts	217
7.1	Introduction	217
7.2	DressPack cable package IRBDP SW6 LI	218
7.3	DressPack cable package IRBDP SW6 UI	219
7.4	DressPack cable package IRBDP MH3 UI	220
7.5	DressPack cable package IRBDP MH LI	221
7.6	DressPack cable package IRBDP MH6 UI	222
7.7	Sub cables	223
7.8	Wear parts	224
7.9	Connection kits	226
7.10	7th axis to base	227
7.11	DressPack floor	228
7.12	Customer signal/power	229
7.13	Water and air unit	231
7.13.1	DressPack - Water and air unit	232
8	Circuit diagrams	233
8.1	Circuit diagrams	233
Index		235

Overview of this manual

About this manual

This manual contains instructions for:

- mechanical and electrical work for DressPack systems
- maintenance of the DressPack systems
- mechanical and electrical repair of the DressPack systems.

The manual also contains reference information for all procedures detailed in the manual.

Usage

This manual should be used during:

- installation of the DressPack system
- maintenance of the DressPack system
- repair work of the DressPack system.

Who should read this manual?

This manual is intended for:

- installation personnel
- maintenance personnel
- repair personnel.

Prerequisites

A maintenance/repair/installation craftsman working with an ABB Robot must:

- be trained by ABB and have the required knowledge of mechanical and electrical installation/repair/maintenance work.

Organization of chapters

The manual is organized in the following chapters:

Chapter	Contents
Safety	Safety information that must be read through before performing any installation or service work on the robot. Contains general safety aspects as well as more specific information on how to avoid personal injuries and damage to the product.
Installation	Descriptions of mechanical installation and electrical connections.
Maintenance	Descriptions of all required preventive maintenance procedures including intervals.
Repair	Descriptions of all recommended repair procedures.
Reference information	Useful information when performing installation, maintenance or repair work. Includes lists of necessary tools, additional documents, safety standards etc.
Spare parts	Complete spare part list and list of robot components, shown in exploded views.
Circuit diagram	References to the circuit diagrams.

Continues on next page

References

Reference	Document ID
<i>Safety manual for robot - Manipulator and IRC5 or OmniCore controller</i> ⁱ	3HAC031045-001
<i>Product manual - IRB 8700</i>	3HAC052853-001
<i>Product manual, spare parts - IRB 8700</i>	3HAC052854-001
<i>Product manual - IRC5</i> IRC5 with main computer DSQC1000.	3HAC047136-001
<i>Product manual - OmniCore V400XT</i>	3HAC081697-001

ⁱ This manual contains all safety instructions from the product manuals for the manipulators and the controllers.

Revisions

Revision	Description
-	First edition.
A	Published in release R16.2. The following updates are made in this revision: <ul style="list-style-type: none"> Updated spare parts numbers for MH6 harnesses (upper arm). Updated spare parts numbers for MH3 harnesses (upper arm). Information about Spot welding cabinet removed. <i>Product manual - Spot welding cabinet IRC5 (3HAC058524-001)</i> describes the Spot welding cabinet.
B	Published in release R17.2. The following updates are made in this revision: <ul style="list-style-type: none"> Updated list of applicable standards Installation of Water and air unit, procedure updated
C	Published in release R19C. The following updates are made in this revision: <ul style="list-style-type: none"> Safety section restructured. Information about functional ground added throughout the manual.
D	Published in release 21C. The following updates are made in this revision: <ul style="list-style-type: none"> Caution regarding handling connectors with care included in Installation and Repair chapters.
E	Published in release 22B. The following updates are made in this revision: <ul style="list-style-type: none"> Added information about using mounting tools and tightening the M12 Ethernet/PROFINET floor cable connector with a tightening torque.
F	Published in release 22C. The following updates are made in this revision: <ul style="list-style-type: none"> Added more specific information about what torque tool to use for M12 Ethernet/PROFINET connectors throughout the manual.
G	Published in release 23D. The following updates are made in this revision: <ul style="list-style-type: none"> Added more specific information about materials, tightening torque and lubrication for couplings.
H	Published in release 24D. The following updates are made in this revision: <ul style="list-style-type: none"> Changed locking liquid Loctite 243 to Loctite 2400. Updated customer signal/power floor cables in spare part chapter.

Product documentation

Categories for user documentation from ABB Robotics

The user documentation from ABB Robotics is divided into a number of categories. This listing is based on the type of information in the documents, regardless of whether the products are standard or optional.



Tip

All documents can be found via myABB Business Portal, www.abb.com/myABB.

Product manuals

Manipulators, controllers, DressPack, and most other hardware is delivered with a **Product manual** that generally contains:

- Safety information.
- Installation and commissioning (descriptions of mechanical installation or electrical connections).
- Maintenance (descriptions of all required preventive maintenance procedures including intervals and expected life time of parts).
- Repair (descriptions of all recommended repair procedures including spare parts).
- Calibration.
- Troubleshooting.
- Decommissioning.
- Reference information (safety standards, unit conversions, screw joints, lists of tools).
- Spare parts list with corresponding figures (or references to separate spare parts lists).
- References to circuit diagrams.

Technical reference manuals

The technical reference manuals describe reference information for robotics products, for example lubrication, the RAPID language, and system parameters.

Application manuals

Specific applications (for example software or hardware options) are described in **Application manuals**. An application manual can describe one or several applications.

An application manual generally contains information about:

- The purpose of the application (what it does and when it is useful).
- What is included (for example cables, I/O boards, RAPID instructions, system parameters, software).
- How to install included or required hardware.
- How to use the application.

Continues on next page

- Examples of how to use the application.

Operating manuals

The operating manuals describe hands-on handling of the products. The manuals are aimed at those having first-hand operational contact with the product, that is production cell operators, programmers, and troubleshooters.

How to read the product manual

Reading the procedures

The procedures contain references to figures, tools, material, and so on. The references are read as described below.

References to figures

The procedures often include references to components or attachment points located on the manipulator/controller. The components or attachment points are marked with *italic text* in the procedures and completed with a reference to the figure where the current component or attachment point is shown.

The denomination in the procedure for the component or attachment point corresponds to the denomination in the referenced figure.

The table below shows an example of a reference to a figure from a step in a procedure.

	Action	Note/Illustration
8.	Remove the <i>rear attachment screws, gearbox</i> .	Shown in the figure Location of gearbox on page xx .

References to required equipment

The procedures often include references to equipment (spare parts, tools, etc.) required for the different actions in the procedure. The equipment is marked with *italic text* in the procedures and completed with a reference to the section where the equipment is listed with further information, that is article number and dimensions.

The designation in the procedure for the component or attachment point corresponds to the designation in the referenced list.

The table below shows an example of a reference to a list of required equipment from a step in a procedure.

	Action	Note/Illustration
3.	Fit a new <i>sealing, axis 2</i> to the gearbox.	Art. no. is specified in Required equipment on page xx .

Safety information

The manual includes a separate safety chapter that must be read through before proceeding with any service or installation procedures. All procedures also include specific safety information when dangerous steps are to be performed.

Read more in the chapter [Safety on page 15](#).

Illustrations

The robot is illustrated with general figures that does not take painting or protection type in consideration.

Likewise, certain work methods or general information that is valid for several robot models, can be illustrated with illustrations that show a different robot model than the one that is described in the current manual.

Product name principles

General

The different robots have a wide range of options. In many cases the option name gives a good explanation of its content. In some cases there is a need to add more information in the product name in order to clearly show a certain variant and to avoid misunderstandings. Hence a complementary naming standard is used.

The family name of the options is DressPack (that is customer cables and hoses from the controller to the robot's axis 6, divided in different sections).

DressPack parts

DressPack parts that are assembled on the robot are called:

- IRBDP (IRB DressPack)

Main application

The DressPack has been prepared for two main applications:

Product name	Application
MH	Material handling
SW	Spot welding

Generations

The different generations of a DressPack is indicated with a generation number. The number indicates the different design of each generation. (Some generations might not be available since it has been phased out).

- 1, 2, 3 etc

Sections

The DressPack on the robot is supplied in different sections:

Product name	Section
L	Lower DressPack section
U	Upper DressPack section
C	Continuous DressPack (DressPack without an intermediate connection point)

Routing

The DressPack can be routed in different ways:

Product name	Routing
I	Integrated DressPack The main parts are integrated within the robot structure.
E	External DressPack The main parts are routed outside, on the robot structure.

Continues on next page

Examples

- **IRBDP MH 3 UE** = IRB DressPack / Material handling application / Generation 3 / Upper arm DressPack section / External routing
- **IRBDP SW 4 UI** = IRB DressPack / Spot welding application / Generation 4 / Upper arm DressPack section / Internal routing
- **IRBDP SW 2 LE** = IRB DressPack / Spot welding application / Generation 2 / Lower arm DressPack section / External routing
- **IRBDP SW 2 CE** = IRB DressPack / Spot welding application / Generation 2 / Continuous DressPack section / External routing

This page is intentionally left blank

1 Safety

1.1 Safety information

1.1.1 Limitation of liability

Limitation of liability

Any information given in this manual regarding safety must not be construed as a warranty by ABB that the industrial robot will not cause injury or damage even if all safety instructions are complied with.

The information does not cover how to design, install and operate a robot system, nor does it cover all peripheral equipment that can influence the safety of the robot system.

In particular, liability cannot be accepted if injury or damage has been caused for any of the following reasons:

- Use of the robot in other ways than intended.
- Incorrect operation or maintenance.
- Operation of the robot when the safety devices are defective, not in their intended location or in any other way not working.
- When instructions for operation and maintenance are not followed as intended.
- Non-authorized design modifications of the robot.
- Repairs on the robot and its spare parts carried out by in-experienced or non-qualified personnel.
- Foreign objects.
- Force majeure.

Spare parts and equipment

ABB supplies original spare parts and equipment which have been tested and approved for their intended use. The installation and/or use of non-original spare parts and equipment can negatively affect the safety, function, performance, and structural properties of the robot. ABB is not liable for damages caused by the use of non-original spare parts and equipment.

1 Safety

1.1.2 Requirements on personnel

1.1.2 Requirements on personnel

General

Only personnel with appropriate training are allowed to install, maintain, service, repair, and use the robot. This includes electrical, mechanical, hydraulics, pneumatics, and other hazards identified in the risk assessment.

Persons who are under the influence of alcohol, drugs or any other intoxicating substances are not allowed to install, maintain, service, repair, or use the robot.

The plant liable must make sure that the personnel is trained on the robot, and on responding to emergency or abnormal situations.

Personal protective equipment

Use personal protective equipment, as stated in the instructions.

1.2 Safety signals and symbols

1.2.1 Safety signals in the manual







Introduction to safety signals

This section specifies all safety signals used in the user manuals. Each signal consists of:

- A caption specifying the hazard level (DANGER, WARNING, or CAUTION) and the type of hazard.
- Instruction about how to reduce the hazard to an acceptable level.
- A brief description of remaining hazards, if not adequately reduced.

Hazard levels

The table below defines the captions specifying the hazard levels used throughout this manual.

Symbol	Designation	Significance
	DANGER	Signal word used to indicate an imminently hazardous situation which, if not avoided, will result in serious injury.
	WARNING	Signal word used to indicate a potentially hazardous situation which, if not avoided, could result in serious injury.
	ELECTRICAL SHOCK	Signal word used to indicate a potentially hazardous situation related to electrical hazards which, if not avoided, could result in serious injury.
	CAUTION	Signal word used to indicate a potentially hazardous situation which, if not avoided, could result in slight injury.
	NOTE	Signal word used to indicate important facts and conditions.
	TIP	Signal word used to indicate where to find additional information or how to do an operation in an easier way.

1 Safety

1.2.2 Safety symbols on manipulator labels

1.2.2 Safety symbols on manipulator labels

Introduction to symbols

This section describes safety symbols used on labels (stickers) on the manipulator. Symbols are used in combinations on the labels, describing each specific warning. The descriptions in this section are generic, the labels can contain additional information such as values.



Note

The symbols on the labels on the product must be observed. Additional symbols added by the integrator must also be observed.



Types of symbols

Both the manipulator and the controller are marked with symbols, containing important information about the product. This is important for all personnel handling the robot, for example during installation, service, or operation.



The safety labels are language independent, they only use graphics. See [Symbols on safety labels on page 18](#).

The information labels can contain information in text.

Symbols on safety labels

Symbol	Description
 xx0900000812	Warning! Warns that an accident <i>may</i> occur if the instructions are not followed that can lead to serious injury, possibly fatal, and/or great damage to the product. It applies to warnings that apply to danger with, for example, contact with high voltage electrical units, explosion or fire risk, risk of poisonous gases, risk of crushing, impact, fall from height, etc.
 xx0900000811	Caution! Warns that an accident may occur if the instructions are not followed that can result in injury and/or damage to the product. It also applies to warnings of risks that include burns, eye injury, skin injury, hearing damage, crushing or slipping, tripping, impact, fall from height, etc. Furthermore, it applies to warnings that include function requirements when fitting and removing equipment where there is a risk of damaging the product or causing a breakdown.
 xx0900000839	Prohibition Used in combinations with other symbols.

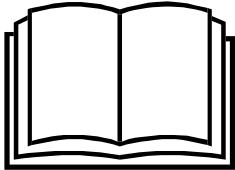
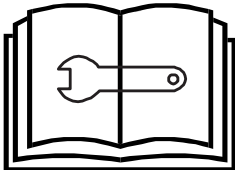
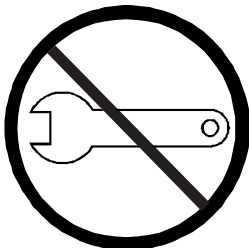
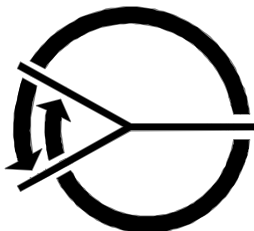

Continues on next page

Symbol	Description
 <p>xx0900000813</p>	<p>See user documentation Read user documentation for details. Which manual to read is defined by the symbol:</p> <ul style="list-style-type: none"> • No text: <i>Product manual</i>. • EPS: <i>Application manual - Electronic Position Switches</i>.
 <p>xx0900000816</p>	<p>Before disassembly, see product manual</p>
 <p>xx0900000815</p>	<p>Do not disassemble Disassembling this part can cause injury.</p>
 <p>xx0900000814</p>	<p>Extended rotation This axis has extended rotation (working area) compared to standard.</p>
 <p>xx0900000808</p>	<p>Brake release Pressing this button will release the brakes. This means that the robot arm can fall down.</p>

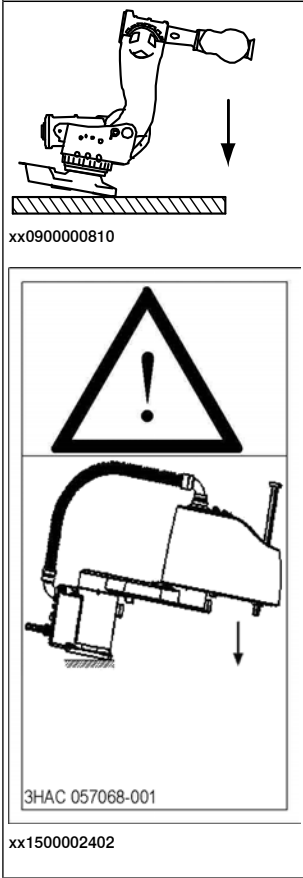

1 Safety

1.2.2 Safety symbols on manipulator labels

Continued

Symbol	Description
 <p>xx0900000810</p> <p>3HAC 057068-001</p> <p>xx1500002402</p>	<p>Tip risk when loosening bolts The robot can tip over if the bolts are not securely fastened.</p>
 <p>xx0900000817</p>	<p>Crush Risk of crush injuries.</p>



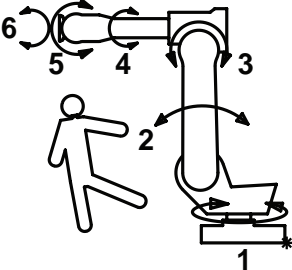
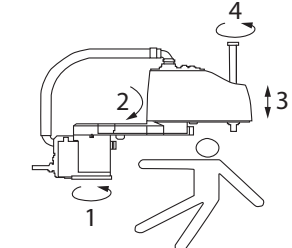
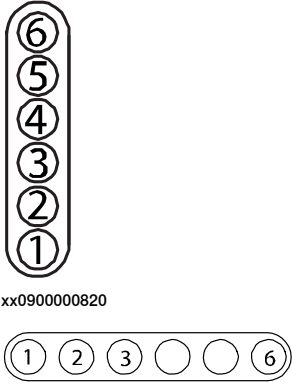



Continues on next page

Symbol	Description
 <p>xx0900000818</p>  <p>xx1300001087</p>	<p>Heat Risk of heat that can cause burns. (Both signs are used)</p>
 <p>xx2400000736</p>  <p>xx1500002616</p>	<p>Moving robot The robot can move unexpectedly.</p>
 <p>xx0900000820</p> <p>xx1000001140</p>	<p>Brake release buttons</p>



1 Safety

1.2.2 Safety symbols on manipulator labels

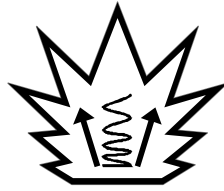
Continued

Symbol	Description
 xx0900000821	Lifting bolt
 xx1000001242	Adjustable chain sling with shortener
 xx0900000822	Lifting of robot
 xx0900000823	Oil Can be used in combination with prohibition if oil is not allowed.
 xx0900000824	Mechanical stop
 xx1000001144	No mechanical stop
 xx0900000825	Stored energy Warns that this part contains stored energy. Used in combination with <i>Do not disassemble</i> symbol.

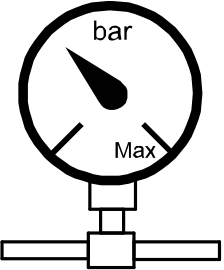
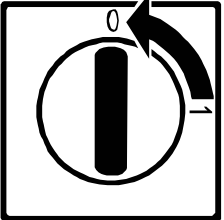
Continues on next page

Symbol	Description
 <p data-bbox="451 589 563 607">xx0900000826</p>	<p data-bbox="759 315 863 338">Pressure</p> <p data-bbox="759 349 1436 405">Warns that this part is pressurized. Usually contains additional text with the pressure level.</p>
 <p data-bbox="451 882 563 900">xx0900000827</p>	<p data-bbox="759 647 991 669">Shut off with handle</p> <p data-bbox="759 680 1190 703">Use the power switch on the controller.</p>
 <p data-bbox="451 1189 563 1207">xx1400002648</p>	<p data-bbox="759 940 895 963">Do not step</p> <p data-bbox="759 974 1436 1030">Warns that stepping on these parts can cause damage to the parts.</p>

1 Safety

1.3 Robot stopping functions

1.3 Robot stopping functions

Protective stop and emergency stop

The protective stops and emergency stops are described in the product manual for the controller.

For more information see:

- *Product manual - IRC5*

1.4 Safety during installation and commissioning

National or regional regulations

The integrator of the robot system is responsible for the safety of the robot system.

The integrator is responsible that the robot system is designed and installed in accordance with the safety requirements set forth in the applicable national and regional standards and regulations.

The integrator of the robot system is required to perform a risk assessment.

Layout

The robot integrated to a robot system shall be designed to allow safe access to all spaces during installation, operation, maintenance, and repair.

If robot movement can be initiated from an external control panel then an emergency stop must also be available.

Consider exposure to hazards, such as slipping, tripping, and falling.

Hazards due to the working position and posture for a person working with or near the robot shall be considered.

Hazards due to noise emission from the robot needs to be considered.

Consider hazards from other equipment in the robot system, for example, that guards remain active until identified hazards are reduced to an acceptable level.

Allergenic material

See [Environmental information on page 205](#) for specification of allergenic materials in the product, if any.

Securing the robot to the foundation

The robot must be properly fixed to its foundation/support, as described in the respective product manual.

When the robot is installed at a height, hanging, or other than mounted directly on the floor, there will be additional hazards.

Using lifting accessories and other external equipment

Ensure that all equipment used during installation, service and all handling of the robot are in correct condition for the intended use.

Electrical safety

Incoming mains must be installed to fulfill national regulations.

The power supply wiring to the robot must be sufficiently fused and if necessary, it must be possible to disconnect it manually from the mains power.

The power to the robot must be turned off with the main switch and the mains power disconnected when performing work inside the controller cabinet. Lock and tag shall be considered.

Harnesses between controller and manipulator shall be fixed and protected to avoid tripping and wear.

Continues on next page

1 Safety

1.4 Safety during installation and commissioning

Continued

Wherever possible, power on/off or rebooting the robot controller shall be performed with all persons outside the safeguarded space.



Note

Use a CARBON DIOXIDE (CO₂) extinguisher in the event of a fire in the robot.

Safety devices

The integrator is responsible for that the safety devices necessary to protect people working with the robot system are designed and installed correctly.

When integrating the robot with external devices to a robot system:

- The integrator of the robot system must ensure that emergency stop functions are interlocked in accordance with applicable standards.
- The integrator of the robot system must ensure that safety functions are interlocked in accordance with applicable standards.

Other hazards

The risk assessment should also consider other hazards arising from the application, such as, but not limited to:

- Water
- Compressed air
- Hydraulics

End-effector hazards require particular attention for applications which involve close human collaboration with the robot.

Pneumatic or hydraulic related hazards



Note

The pressure in the complete pneumatic or hydraulic systems must be released before service and maintenance.

All components in the robot system that remain pressurized after switching off the power to the robot must be marked with clearly visible drain facilities and a warning sign that indicates the hazard of stored energy.

Loss of pressure in the robot system may cause parts or objects to drop.

Dump valves should be used in case of emergency.

Shot bolts should be used to prevent tools, etc., from falling due to gravity.

All pipes, hoses, and connections have to be inspected regularly for leaks and damage. Damage must be repaired immediately.

Verify the safety functions

Before the robot system is put into operation, verify that the safety functions are working as intended and that any remaining hazards identified in the risk assessment are mitigated to an acceptable level.

1.5 Safety during operation

Automatic operation

Verify the application in the operating mode manual reduced speed, before changing mode to automatic and initiating automatic operation.

Unexpected movement of robot arm



WARNING

Hazards due to the use of brake release devices and/or gravity beneath the manipulator shall be considered.

1 Safety

1.6.1 Safety during maintenance and repair

1.6 Safety during maintenance and repair

1.6.1 Safety during maintenance and repair

General

Corrective maintenance must only be carried out by personnel trained on the robot. Maintenance or repair must be done with all electrical, pneumatic, and hydraulic power switched off, that is, no remaining hazards.

Hazards due to stored mechanical energy in the manipulator for the purpose of counterbalancing axes must be considered before maintenance or repair.

Never use the robot as a ladder, which means, do not climb on the controller, manipulator, including motors, or other parts. There are hazards of slipping and falling. The robot might be damaged.

Make sure that there are no tools, loose screws, turnings, or other unexpected parts remaining after maintenance or repair work.

When the work is completed, verify that the safety functions are working as intended.

Hot surfaces

Surfaces can be hot after running the robot, and touching these may result in burns. Allow the surfaces to cool down before maintenance or repair.

Allergic reaction

Warning	Description	Elimination/Action
 Allergic reaction	When working with lubricants there is a risk of an allergic reaction.	Make sure that protective gear like goggles and gloves are always worn.

Gearbox lubricants (oil or grease)

When handling oil, grease, or other chemical substances the safety information of the respective manufacturer must be observed.









Note

Take special care when handling hot lubricants.

Warning	Description	Elimination/Action
 Hot oil or grease	Changing and draining gearbox oil or grease may require handling hot lubricant heated up to 90 °C.	Make sure that protective gear like goggles and gloves are always worn during this activity.

Continues on next page

Warning	Description	Elimination/Action
 Allergic reaction	When working with lubricants there is a risk of an allergic reaction.	Make sure that protective gear like goggles and gloves are always worn.
 Possible pressure build-up in gearbox	When opening the oil or grease plug, there may be pressure present in the gearbox, causing hot lubricant to spray from the opening.	Open the plug carefully and keep away from the opening. Do not overfill the gearbox when filling. Put oil absorbent cloth, bags or paper at appropriate locations to catch any oil residues. Use appropriate protective gear such as heat-resistant gloves, goggles/protective visor, or a body suit if necessary.
 Do not overfill	Overfilling of gearbox lubricant can lead to internal over-pressure inside the gearbox which in turn may: <ul style="list-style-type: none"> • damage seals and gaskets • completely press out seals and gaskets • prevent the robot from moving freely. 	Make sure not to overfill the gearbox when filling it with oil or grease. After filling, verify that the level is correct.
 Do not mix types of oil	Mixing types of oil may cause severe damage to the gearbox.	When filling gearbox oil, do not mix different types of oil unless specified in the instructions. Always use the type of oil specified for the product.
 Oil residues	Oil residues might be present in a drained gearbox and spilled when separating a motor and gearbox during repair.	Make sure that protective gear like goggles/protective visor, gloves and arm protection are always worn during this activity. Put oil absorbent cloth, bags or paper at appropriate locations to catch any oil residues.
 Heat up the oil	Warm oil drains quicker than cold oil.	Run the robot before changing the gearbox oil, if possible.
 Specified amount depends on drained volume	The specified amount of oil or grease is based on the total volume of the gearbox. When changing the lubricant, the amount refilled may differ from the specified amount, depending on how much has previously been drained from the gearbox.	After filling, verify that the level is correct.

Continues on next page

1 Safety

1.6.1 Safety during maintenance and repair

Continued

Warning	Description	Elimination/Action
 Contaminated oil in gearboxes	For lifetime reasons always drain as much oil as possible from the gearbox. The magnetic oil plugs will gather residual metal chips.	

Hazards related to batteries

Under rated conditions, the electrode materials and liquid electrolyte in the batteries are sealed and not exposed to the outside.

There is a hazard in case of abuse (mechanical, thermal, electrical) which leads to the activation of safety valves and/or the rupture of the battery container. As a result under certain circumstances, electrolyte leakage, electrode materials reaction with moisture/water or battery vent/explosion/fire may follow.

Do not short circuit, recharge, puncture, incinerate, crush, immerse, force discharge or expose to temperatures above the declared operating temperature range of the product. Risk of fire or explosion.

See safety instructions for the batteries in *Material/product safety data sheet - Battery pack (3HAC043118-001)*.

Related information

See also the safety information related to installation and operation.

1.7 Safety during troubleshooting

General

When troubleshooting requires work with power switched on, special considerations must be taken:

- Safety circuits might be muted or disconnected.
- Electrical parts must be considered as *live*.
- The manipulator can move unexpectedly at any time.



DANGER

Troubleshooting on the controller while powered on must be performed by personnel trained by ABB or by ABB field engineers.

A risk assessment must be done to address both robot and robot system specific hazards.

Related information

See also the safety information related to installation, operation, maintenance, and repair.

1 Safety

1.8 Safety during decommissioning

1.8 Safety during decommissioning

General

See section [Decommissioning on page 205](#).

If the robot is decommissioned for storage, take extra precaution to reset safety devices to delivery status.

2 Installation

2.1 Introduction

General

This chapter presents general information, complementing the more specific information in the following chapters.

Sections

The installation chapter is divided in the following sections:

- Fitting DressPack cable package attachments
- Fitting DressPack cable packages
- DressPack floor cable

2 Installation

2.2 Overview

2.2 Overview

General

Installing, programming and operating the ABB DressPack product program may be a complex task as each application instance is very specific. The product is designed to fit a wide variety of applications, and must be adapted to each in order to maximize life and function.

The generic installation procedure is described below.



CAUTION

The cabling is sensitive to mechanical damage. Handle it with care to avoid damage to the cabling or the connector, avoid any kind of tilt or skew.

Limitations of robot movements

When using DressPack options on the upper arm, the robot movements will be limited.

- In bending backwards positions there are limitations due to interference with the robot itself

Effects on arm load and performance



Note

The extra weight of the DressPack products will affect the arm load data and the performance of the robot. The effect differs depending on which type of DressPack product. See [DressPack - arm load parameters and LoadId](#).

2.3 Fitting the process turning disc

Location of the process turning disc

The process turning disc is located in the front of the wrist housing as shown in the figure.

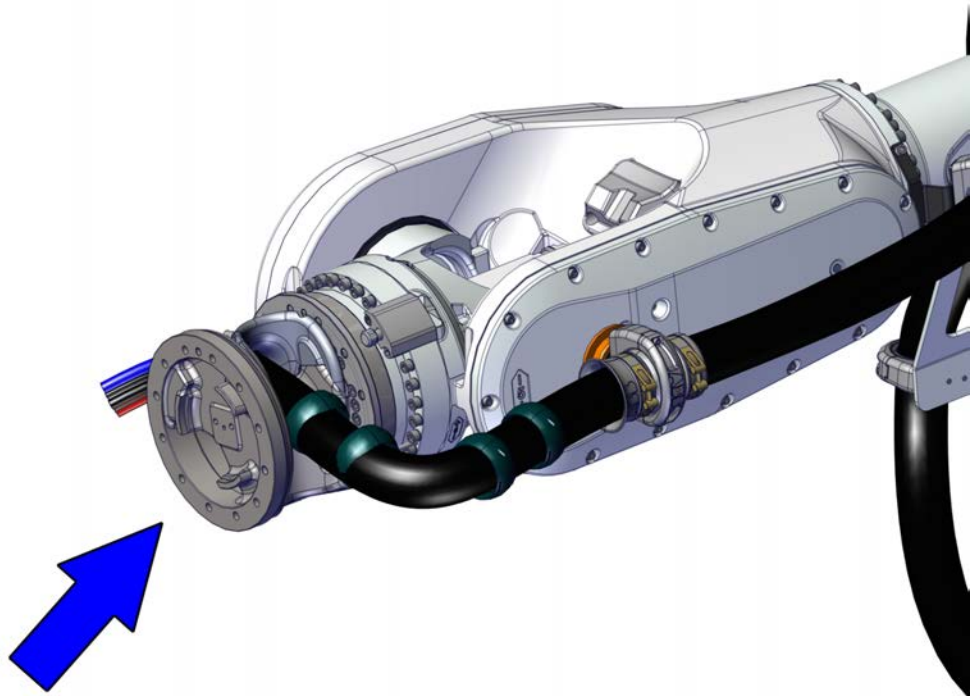

xx1500003047

Required tools and equipment

Equipment, etc.	Article number	Note
Standard toolkit	-	Content is defined in section Standard toolkit on page 213 .
Roundsling 1 m	-	Lifting capacity: 1,000 kg

Fitting the process turning disc

Screw joints for fitting the process turning disc

Variant	Screw dimension	Number of screws	Number of washers	Tightening torque
3HAC051003-005	M12x40	22 pcs	22 pcs	120 Nm



Continues on next page

2 Installation

2.3 Fitting the process turning disc

Continued

Fitting the process turning disc

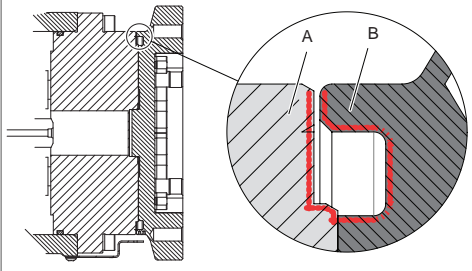
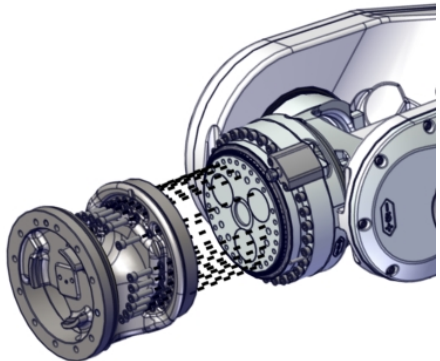
	Action	Note
1	 DANGER Make sure that all supplies for electrical power, hydraulic pressure, and air pressure are turned off.	
2	 CAUTION The process turning disc weight is 50 kg. All lifting equipment must be sized accordingly.	
3	Attach the roundsling to the process turning disc and to an overhead crane or similar.	Roundsling 1 m, Lifting capacity: 1,000 kg
4	Stretch the roundsling to take the weight of the process turning disc.	
5	Wipe clean the contacts surfaces.	
6	<i>Foundry Plus:</i> Apply Mercasol on the surfaces on the process turning disc and axis-6 gearbox as shown in the figure.	 xx1400000385
7	Secure the process turning disc with its attachment screws and washers.	Tightening torque: 120  xx15000003048 M12x40 12.9 Gleitmo 603 (22 pcs)

Continues on next page

Removing the process turning disc

Screw joints for fitting the process turning disc

Variant	Screw dimension	Number of screws	Number of washers	Tightening torque
3HAC051003-005	M12x40	22 pcs	22 pcs	120 Nm

Preparations

	Action	Note
1	Run the robot to a suitable position for removal of the process turning disc.	
2	 DANGER Turn off all: <ul style="list-style-type: none"> • electric power supply • hydraulic pressure supply • air pressure supply to the robot, before entering the safeguarded space.	
3	Remove any equipment fitted to the process turning disc.	

Removing the process turning disc

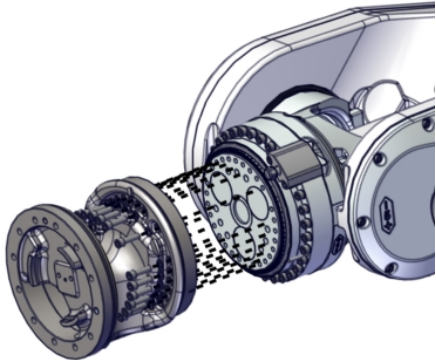
	Action	Note
1	 CAUTION The process turning disc weight is 50 kg. All lifting equipment must be sized accordingly.	
2	Attach the roundsling to the process turning disc and to an overhead crane or similar.	Roundsling 1 m, Lifting capacity: 1,000 kg
3	Stretch the roundsling to take the weight of the process turning disc.	
	Remove the 22 screws and washers that secure the process turning disc.	 <p>xx1500003048</p>

Continues on next page

2 Installation

2.3 Fitting the process turning disc

Continued

	Action	Note
4	Remove the process turning disc.	

2.4 DressPack cable package

2.4.1 Overview

General

Installing, programming and operating the ABB DressPack product program may be a complex task as each application instance is very specific. The product is designed to fit a wide variety of applications, and must be adapted to each in order to maximize life and function.

The generic installation procedure is described below.



CAUTION

The cabling is sensitive to mechanical damage. Handle it with care to avoid damage to the cabling or the connector, avoid any kind of tilt or skew.

Limitations of robot movements

When using DressPack options on the upper arm, the robot movements will be limited.

- In bending backwards positions there are limitations due to interference with the robot itself

Effects on arm load and performance



Note

The extra weight of the DressPack products will affect the arm load data and the performance of the robot. The effect differs depending on which type of DressPack product. See [DressPack - arm load parameters and LoadId](#).

2 Installation

2.4.2.1 Fitting the cable package IRBDP MH LI

2.4.2 Installation of IRBDP MH LI

2.4.2.1 Fitting the cable package IRBDP MH LI

Location of the cable package

The cable package is located inside the lower arm.

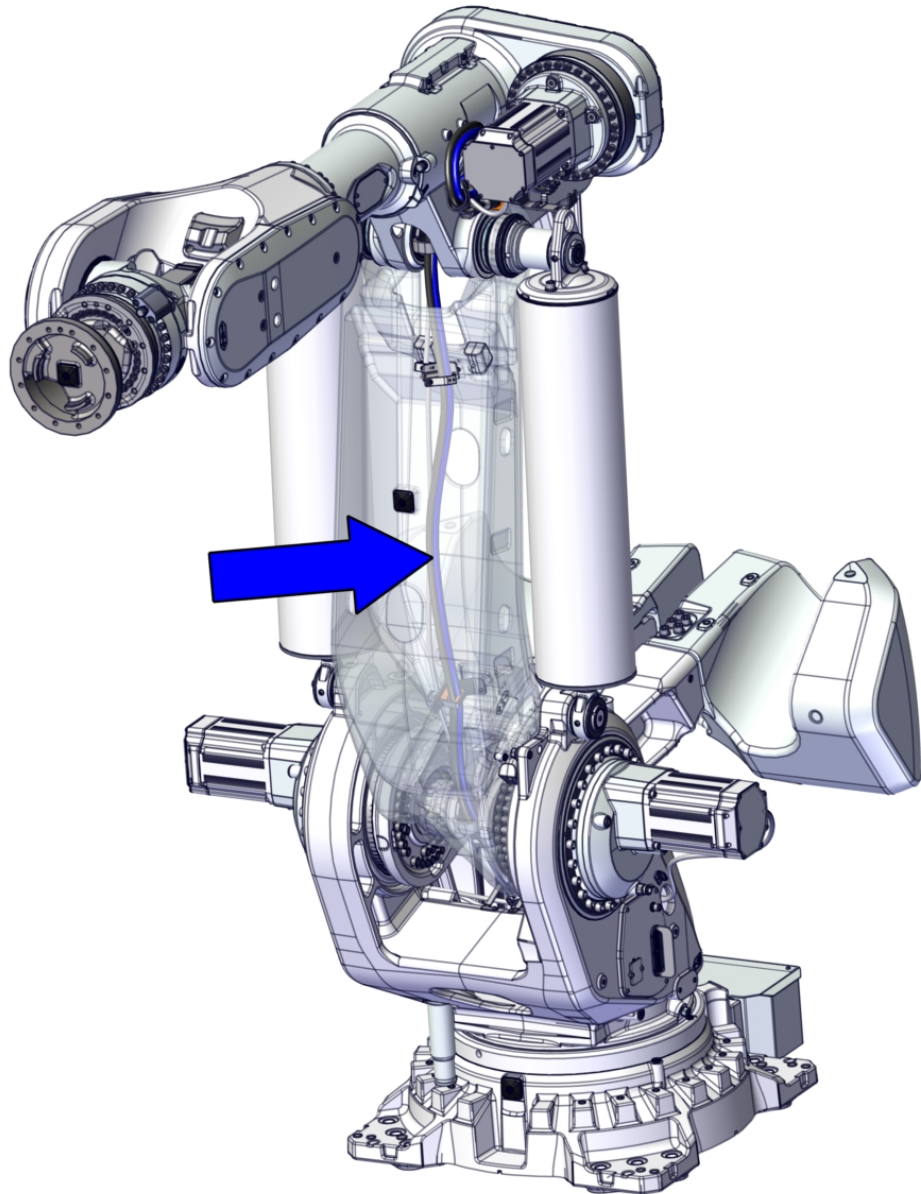

xx1500002962

Spare parts

Equipment, etc.	Article number	Note
Cable package IRBDP MH LI	See DressPack cable package IRBDP MH LI	

Continues on next page

Equipment, etc.	Article number	Note
Material set IRBDP MH LI	3HAC053920-001	

Required tools and equipment

Equipment, etc.	Article number	Note
Standard toolkit, DressPack	-	Content is defined in section Toolkits, DressPack on page 213 .



Consumables

Equipment, etc.	Article number	Note
Locking liquid	-	Loctite 2400 (or equivalent Loctite 243)

Fitting the cable package IRBDP MH LI

Use this procedure to fit the cable package IRBDP MH LI.

Connect the cable package at the base

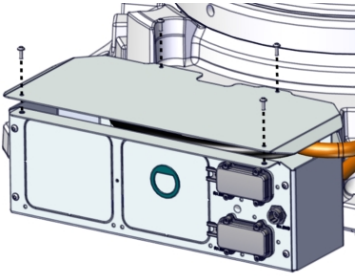
	Action	Note
1	 <p>DANGER</p> <p>Turn off all:</p> <ul style="list-style-type: none"> • electric power supply • hydraulic pressure supply • air pressure supply <p>to the robot, before entering the safeguarded space.</p>	
2	 <p>CAUTION</p> <p>The cable package is sensitive to mechanical damage. Handle it with care in order to avoid damaging the cabling or the connectors.</p>	
3	Remove the rear cover plate.	 <p>xx1500002963</p>

Continues on next page

2 Installation

2.4.2.1 Fitting the cable package IRBDP MH LI

Continued

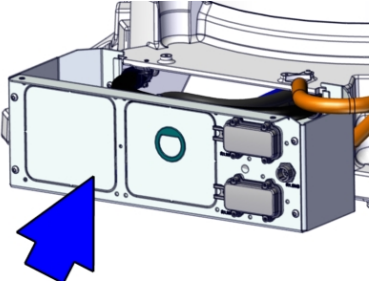
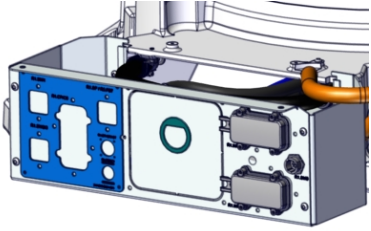
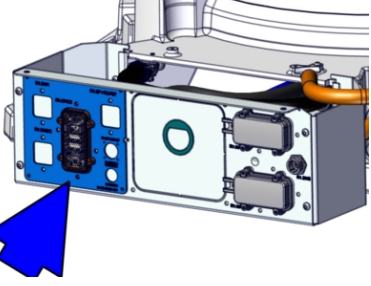
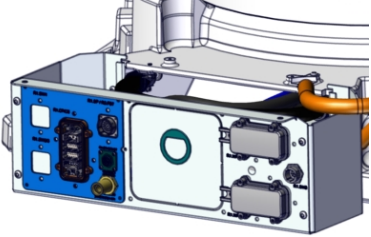
	Action	Note
4	<p>Remove the part of the backplate where the customer plate is to be fitted. Hit the removable part carefully with a plastic mallet.</p> <p> Note</p> <p>Only needed when the DressPack cable package is fitted for the first time.</p>	 <p>xx1500002964</p>
5	Fit the customer plate.	 <p>xx1500002965</p> <p>M6x25 A2-70 (4 pcs)</p>
6	Fit the adapter complete.	 <p>xx1500002966</p> <p>M6x16 Stainless steel A2-70 (2 pcs)</p>
7	Fit the Profinet bracket.	 <p>xx1500002967</p> <p>M3x8 A2-70 (4 pcs)</p>

Continues on next page

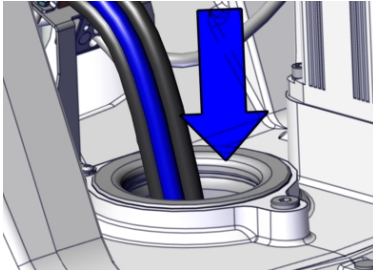
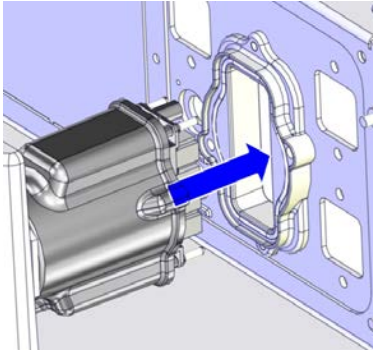
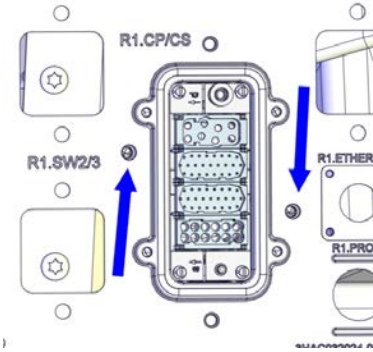

	Action	Note
8	Run the cables down through the center hole of axis 1. <ul style="list-style-type: none"> Make a check that the cables and hoses do not cross each other. 	 <p>xx1500002968</p>
9	Fit the R1.CP/CS cable to the customer plate.	 <p>xx1400001142</p>
10	Secure the R1.CP/CS connector.	 <p>xx1400001143</p> <p>M6x25 A2-70 (2 pcs)</p>

Continues on next page



2 Installation

2.4.2.1 Fitting the cable package IRBDP MH LI

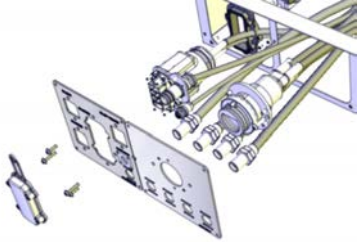
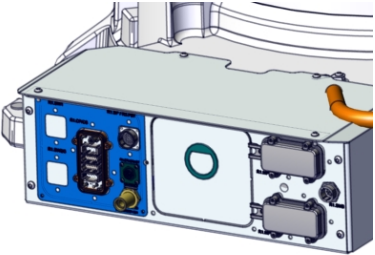
Continued

	Action	Note
11	<p>Connect the rest of the cable and hose connectors to the customer plate.</p> <p> CAUTION</p> <p>Do not tighten the brass couplings for water and air with excessive force.</p> <p> CAUTION</p> <p>Make sure that no cables or hoses are twisted or strained. Reroute if necessary.</p> <p> CAUTION</p> <p>If the M12 Ethernet connector is not tightened correctly, there is a risk that the connector can loosen and the cable shield gets disconnected, which will require retightening with the correct torque tools.</p> <p>For secure connection, always tighten at the knurled screw with correct torque and by using proper torque tool, e.g. M12 dynamometric screwdriver SW15 (09 99 000 0646 (article number at Harting Technology Group)).</p>	<p>Tightening torque:</p> <ul style="list-style-type: none"> • Brass coupling 1/2": 31 Nm. • Stainless steel coupling 1/2": 49 Nm. • Brass coupling 3/8": 17 Nm. • Mixed metals: Use the lower tightening torque value of the two metals. <p>Always apply Molykote P1900 to stainless steel couplings and apply if needed for couplings of mixed metals or brass.</p> <p>Tightening torque, Ethernet M12: 0.6 Nm.</p>  <p>xx120000088</p>
12	<p>Refit the rear cover plate.</p>	 <p>xx1500002969</p>

Refitting the cable package

	Action	Note
1	<p> DANGER</p> <p>Turn off all:</p> <ul style="list-style-type: none"> • electric power supply • hydraulic pressure supply • air pressure supply <p>to the robot, before entering the safeguarded space.</p>	
2	<p> CAUTION</p> <p>The cable package is sensitive to mechanical damage. Handle it with care in order to avoid damaging the cabling or the connectors.</p>	

Continues on next page

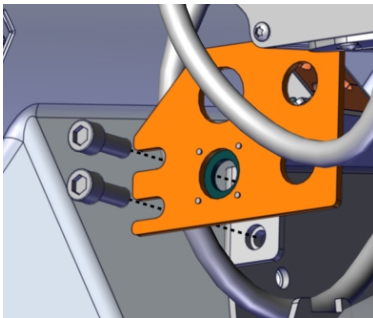
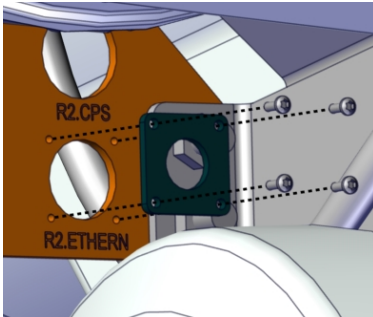
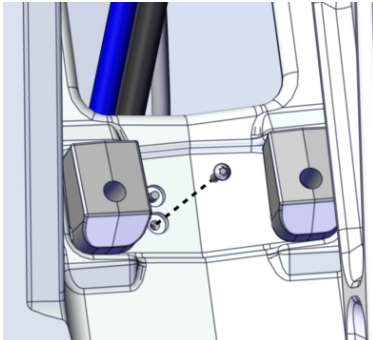
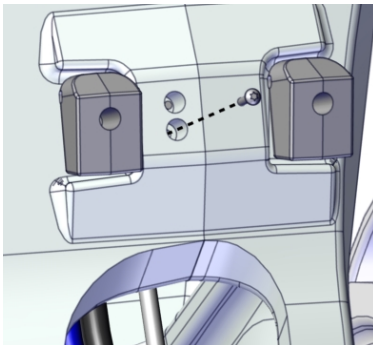
	Action	Note
3	Fit the connection plate. Lock screws with locking liquid.	 <p data-bbox="1059 638 1166 658">xx1500002970</p> <p data-bbox="1059 669 1310 696">M10x25 A2-7 0 (2 pcs)</p>
4	Fasten the Profinet bracket.	 <p data-bbox="1059 1041 1166 1061">xx1500002971</p> <p data-bbox="1059 1072 1278 1099">M3x8 A2-70 (4 pcs)</p>
5	Remove screws for motor cabling brackets inside the lower arm.	 <p data-bbox="1059 1467 1166 1487">xx1500003019</p>  <p data-bbox="1059 1854 1166 1874">xx1500003020</p>
6	Gently push the dresspack cables up into the lower arm.	

Continues on next page

2 Installation

2.4.2.1 Fitting the cable package IRBDP MH LI

Continued

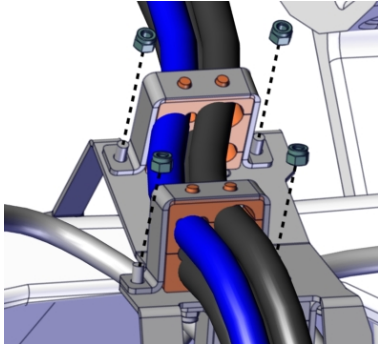
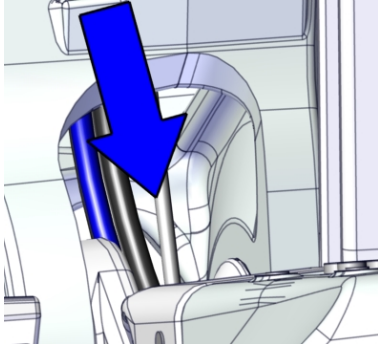
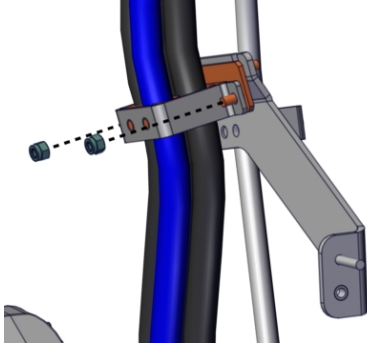
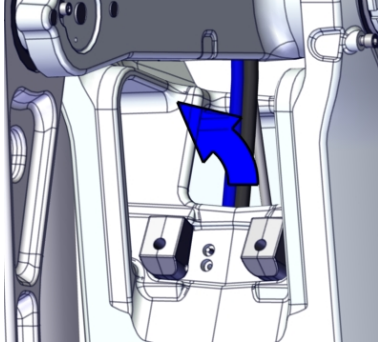
	Action	Note
7	Fit the metal clamps on the motor cabling bracket.	 <p data-bbox="1027 667 1136 685">xx150003022</p> <p data-bbox="1027 696 1315 725">M6 Steel 8-A2F (2x 2 pcs)</p>
8	Gently pull out the motor cabling downwards to be able to fit the dresspack cables on the cabling bracket inside lower arm.	 <p data-bbox="1027 1097 1136 1115">xx150003021</p>
9	Fit the metal clamp.	 <p data-bbox="1027 1496 1136 1514">xx150003023</p> <p data-bbox="1027 1525 1283 1554">M6 Steel 8-A2F (2 pcs)</p>
10	Pull the motor cabling gently upwards until the motor cabling bracket is reachable.	 <p data-bbox="1027 1926 1136 1944">xx150003024</p>

Continues on next page

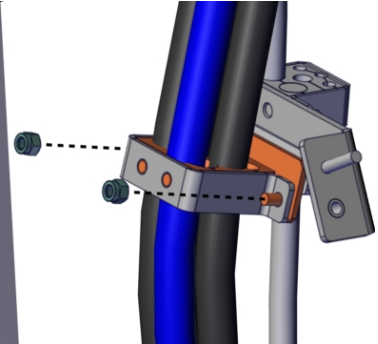
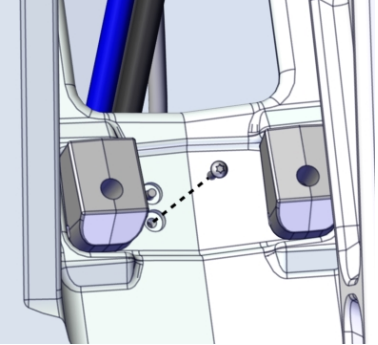
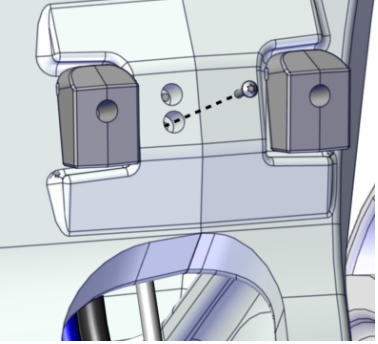
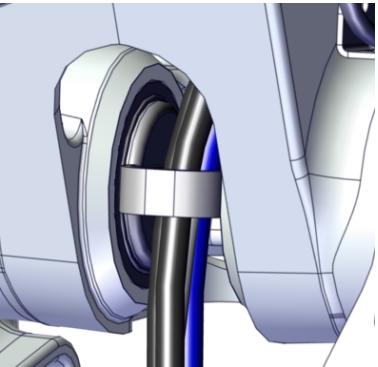

	Action	Note
11	Fit the metal clamp.	 <p data-bbox="1062 667 1166 685">xx1500003025</p> <p data-bbox="1062 696 1313 725">M6 Steel 8-A2F (2 pcs)</p>
12	Fit the motor cabling brackets inside lower arm.	 <p data-bbox="1062 1099 1166 1117">xx1500003019</p>  <p data-bbox="1062 1487 1166 1505">xx1500003020</p>
13	Place the cables in the cable guide.	 <p data-bbox="1062 1899 1166 1917">xx1500003027</p>

Continues on next page

2 Installation

2.4.2.1 Fitting the cable package IRBDP MH LI

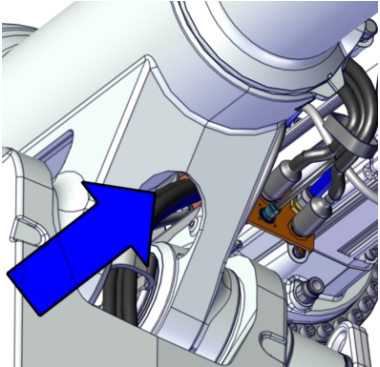
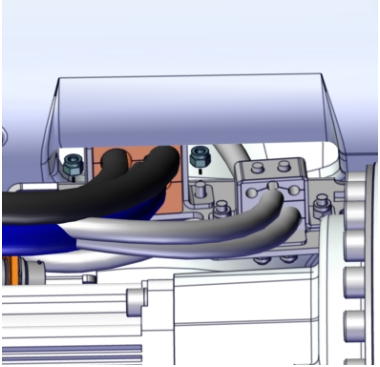
Continued

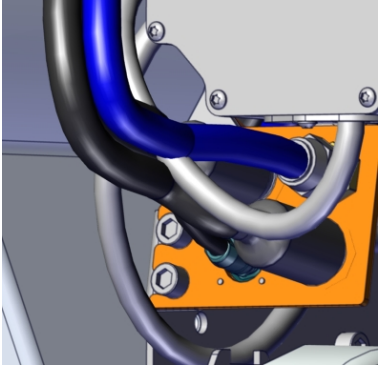
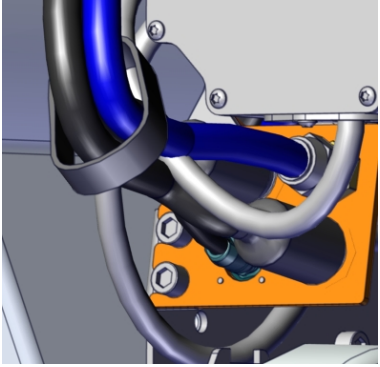
	Action	Note
14	Push the cables out of axis 3-4 beside the motor.	 xx1500003032
15	Fit the metal clamp.	 xx1500003033
16	<p>Carefully bend the cabling and attach it to the connection plate.</p> <p> Tip Start connecting top connectors, and continue downwards.</p>	 xx1500003034
17	Put a strap around the cabling.	 xx1500003035

2.4.3 Installation of IRBDP MH3 UI

2.4.3.1 Fitting attachments of the IRBDP MH3 UI

Location of the attachments

The location of the attachments of the cable package are shown in the figure.

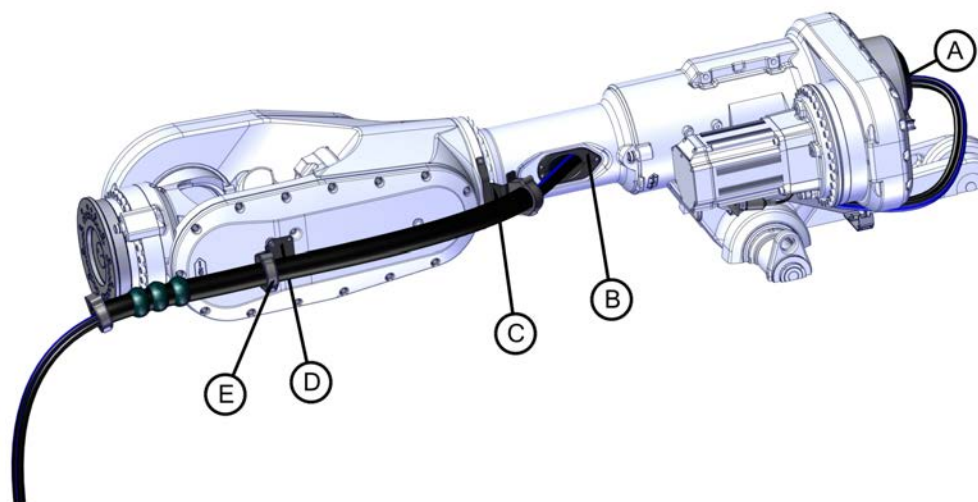

xx1500003001

A	Cover
B	Insert and tube (inside upper arm)
C	Upper arm bracket
D	Wrist bracket
E	Gripping clamp

Required parts

Spare part	Article number	Note
Material set IRBDP MH3 UI	3HAC053947-001	

Required tools and equipment

Equipment, etc.	Article number	Note
Standard toolkit	-	Content is defined in section Standard toolkit on page 213 .

Consumables

Equipment	Article number	Note
Locking liquid	-	Loctite 2400 (or equivalent Loctite 243)

Continues on next page

2 Installation

2.4.3.1 Fitting attachments of the IRBDP MH3 UI

Continued

Fitting the cable package attachments - IRBDP MH3 UI

Use this procedure to fit the cable attachments of the cable package IRBDP MH3 UI.

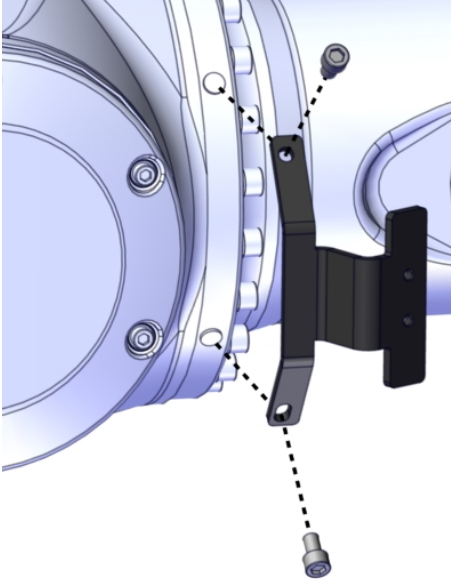
	Action	Note
1	Move the robot to a suitable position for fitting the cable attachments on the upper arm.	
2	 DANGER Turn off all: <ul style="list-style-type: none">• electric power supply• hydraulic pressure supply• air pressure supply to the robot, before entering the safeguarded space.	
3	Fasten the upper arm bracket. Lock screws with locking liquid.	 <p data-bbox="954 1462 1062 1480">xx1500003002</p> <p data-bbox="954 1491 1190 1518">M8x16 A2-7 0 (2 pcs)</p>

Continues on next page

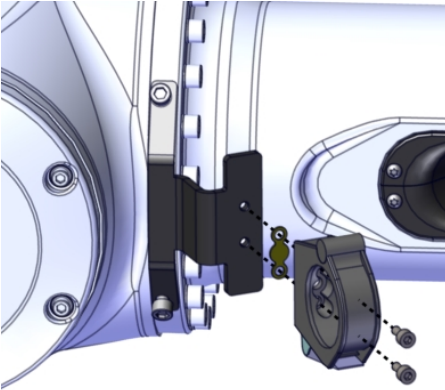
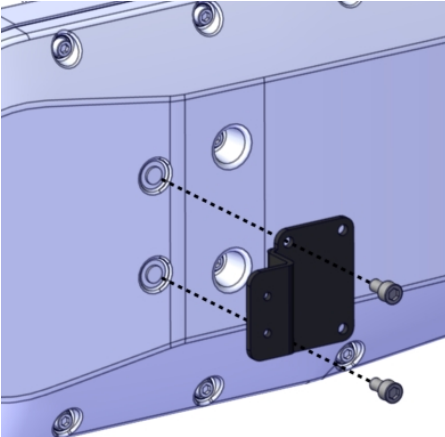
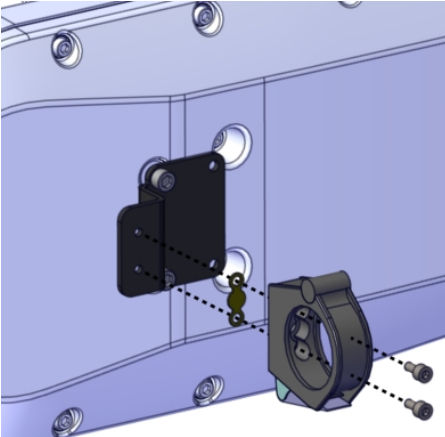
	Action	Note
4	Fasten gripping clamp. Lock screws with locking liquid.	 <p data-bbox="986 763 1222 824">xx1500003016 M8x16 A2-7 0 (2 pcs)</p>
5	Fasten the wrist bracket. Lock screws with locking liquid.	 <p data-bbox="986 1285 1222 1346">xx1500003013 M8x16 A2-7 0 (2 pcs)</p>
6	Fasten gripping clamp. Lock screws with locking liquid.	 <p data-bbox="986 1807 1222 1868">xx1500003017 M8x16 A2-7 0 (2 pcs)</p>

Continues on next page

2 Installation

2.4.3.1 Fitting attachments of the IRBDP MH3 UI

Continued



Fitting insert, tube and cover

Fitting insert, tube and cover

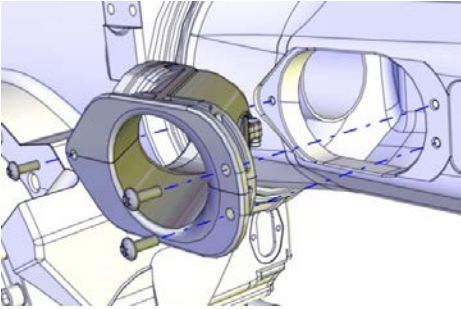
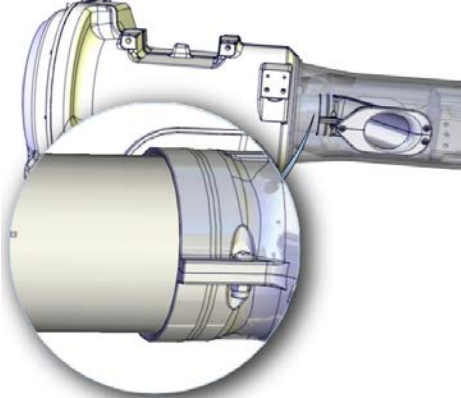
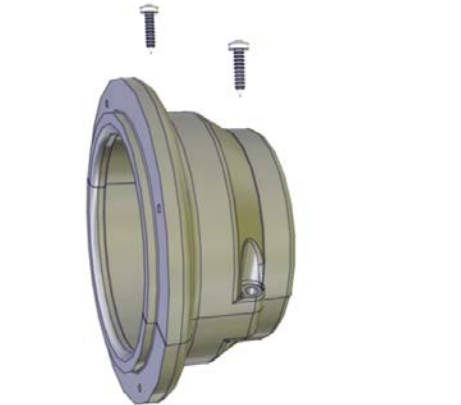
Use this procedure to fit the insert, the tube and the cover.

	Action	Note
1	Fit the insert. Lock screws with locking liquid.	 xx120000042 Screw, M6x16 8.8-A2F (3 pcs)
2	Insert the tube into the arm tube and fit it into the insert.	 xx120000043
3	Mount the two parts of the tube guiding ring.	 xx1200000162 Pan head screw ST3.9x16 (2 pcs).

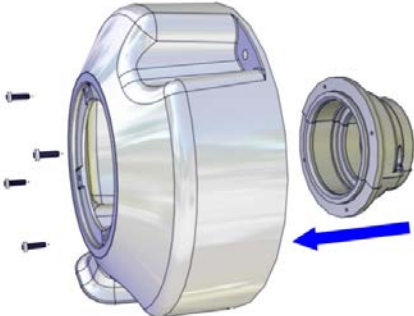
Continues on next page

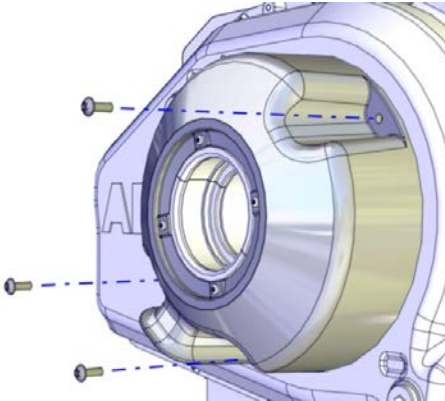
	Action	Note
4	Fit the tube guiding ring in the cover.	 <p data-bbox="970 674 1082 694">xx120000044</p> <p data-bbox="970 703 1433 734">Screw, Pan head screw ST3.9x16 (4 pcs).</p>
5	<p data-bbox="496 750 962 831">Fit the cover, with the tube guiding ring, on the tube and secure it to the armhouse cover. Lock screws with locking liquid.</p> <p data-bbox="496 846 646 904"> Note</p> <p data-bbox="496 920 935 978">Check that the tube is fitted correctly in both ends, when fitting the cover.</p>	 <p data-bbox="970 1160 1082 1180">xx120000045</p> <p data-bbox="970 1189 1401 1220">Screws, M6x16 quality 8.8-A2F (3 pcs)</p>

2 Installation

2.4.3.2 Fitting the cable package IRBDP MH3 UI

2.4.3.2 Fitting the cable package IRBDP MH3 UI

Location of the cable package

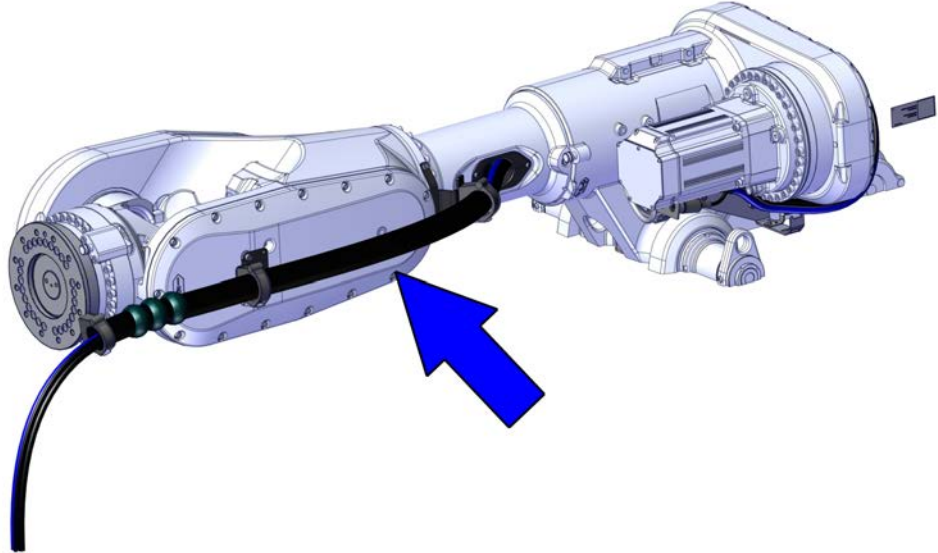

xx1500003018

Required parts

Spare part	Article number	Note
Cable package IRBDP MH3 UI	See DressPack cable package IRBDP MH3 UI on page 220	

Required tools and equipment

Equipment	Article number	Note
Standard toolkit, DressPack	-	Content is defined in section Toolkits, DressPack on page 213 .

Consumables

Equipment	Article number	Note
Locking liquid	-	Loctite 2400 (or equivalent Loctite 243)
Cable grease	3HAC14807-1	Optitemp RB2





Fitting the cable package IRBDP MH3 UI

Use this procedure to fit the cable package IRBDP MH3 UI.

Route the cable package

	Action	Note
1	Move the robot to a comfortable working position.	

Continues on next page

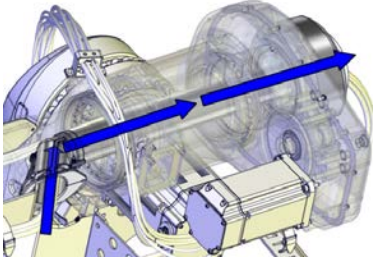
	Action	Note
2	 DANGER Turn off all: <ul style="list-style-type: none"> • electric power supply • hydraulic pressure supply • air pressure supply to the robot, before entering the safeguarded space.	
3	 CAUTION The cable package is sensitive to mechanical damage. Handle it with care in order to avoid damaging the cabling or the connectors.	
4	 Tip This procedure is best done by two persons working together - one pushing cabling and hoses into the tube and the other pulling them out at the wrist.	
5	Carefully push the cable package into the insert, through the tube and out in the back of the arm housing.  Tip The following order is preferable: <ol style="list-style-type: none"> 1 Cables 2 Hoses 3 Weld cables (where applicable) If there is a problem, remove the nut inside the tube.	 <p>xx1400000095</p>

Apply cable grease

It is necessary to apply cable grease on the cable package inside the tube.



	Action	Note
1	Carefully pull the cable package out 10 to 15 centimeters longer than the final assembly position.	

Continues on next page

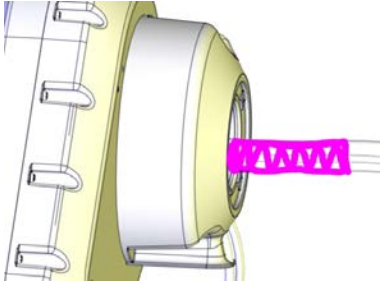
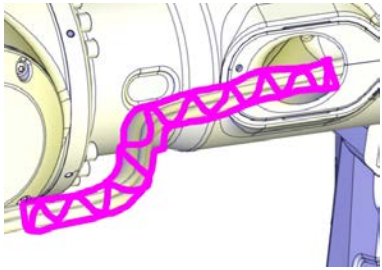

2 Installation

2.4.3.2 Fitting the cable package IRBDP MH3 UI



Continued

	Action	Note
2	Apply grease on the highlighted area.	 xx1400001389
3	Carefully push the cable package back into the tube and out through the insert until the area where grease was applied, is visible and able to reach.	
4	Apply grease on the highlighted area so that the cable package inside the tube is covered with cable grease all the way through.	 xx1400001390
5	Carefully push the cable package back in through the insert and into its mounting position in the tube.	
6	 Note Make sure the cables and hoses are not twisted through the upper arm.	

Connect the cable package

	Action	Note
1	 DANGER Turn off all: <ul style="list-style-type: none"> • electric power supply • hydraulic pressure supply • air pressure supply to the robot, before entering the safeguarded space.	
2	 CAUTION The cable package is sensitive to mechanical damage. Handle it with care in order to avoid damaging the cabling or the connectors.	

Continues on next page

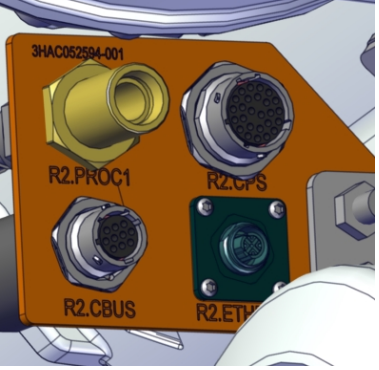
	Action	Note
3	<p>Connect the hose and cable connectors on the connection plate.</p> <p> CAUTION</p> <p>Do not tighten the brass couplings for water and air with excessive force.</p> <p> Tip</p> <p>Start connecting top connectors, and continue downwards.</p> <p> CAUTION</p> <p>If the M12 Ethernet connector is not tightened correctly, there is a risk that the connector can loosen and the cable shield gets disconnected, which will require retightening with the correct torque tools.</p> <p>For secure connection, always tighten at the knurled screw with correct torque and by using proper torque tool, e.g. M12 dynamometric screwdriver SW15 (09 99 000 0646 (article number at Harting Technology Group)).</p>	<p>Tightening torque:</p> <ul style="list-style-type: none"> • Brass coupling 1/2": 31 Nm. • Stainless steel coupling 1/2": 49 Nm. • Brass coupling 3/8": 17 Nm. • Mixed metals: Use the lower tightening torque value of the two metals. <p>Always apply Molykote P1900 to stainless steel couplings and apply if needed for couplings of mixed metals or brass.</p> <p>Tightening torque, Ethernet M12: 0.6 Nm.</p>  <p>xx1500003038</p>

Fitting cable package on the upper arm

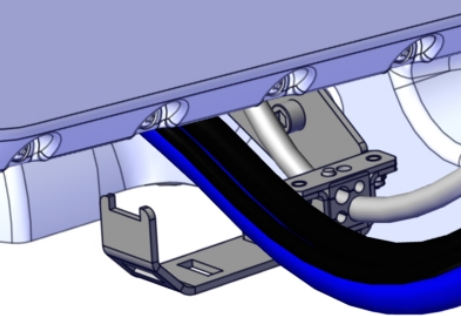
	Action	Note
1	<p>Secure the cable package to the mounting plate with a strap.</p>	 <p>xx1500003039</p>

2 Installation

2.4.3.2 Fitting the cable package IRBDP MH3 UI

Continued

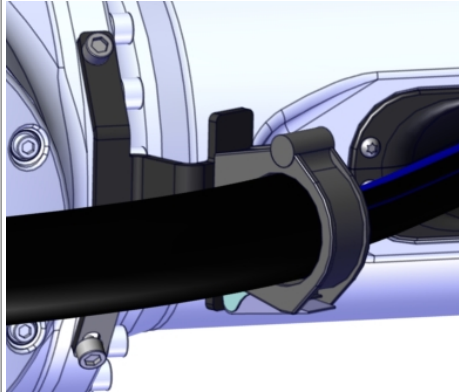
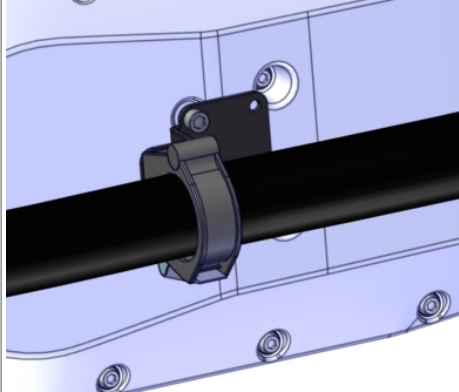
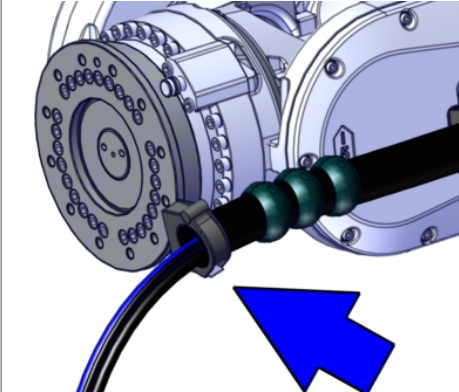
	Action	Note
2	Fasten the cable package in the gripping clamps on the upper arm.	 <p>xx1500003040</p>  <p>xx1500003041</p>
3	The gripping clamp at the front shall be fitted on equipment used by the customer.	 <p>xx1500003042</p>

Continues on next page

Check of protective sleeve

The protective hose is protected against wear in exposed areas with a protective sleeve.

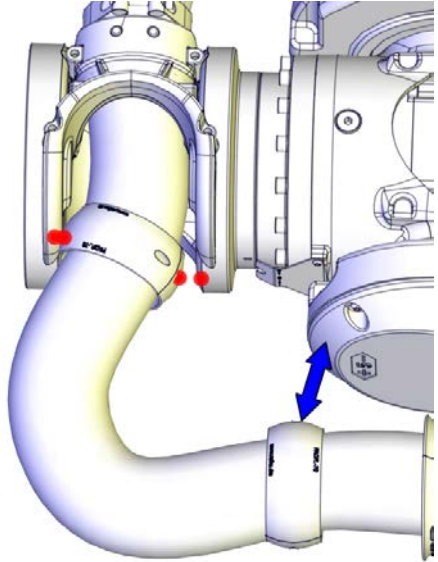
	Action	Note
1	In order to be sure that the protective sleeve is in the correct position, check the position after some hours running.	 <p>xx140000224</p>
2	If the protective hose is worn somewhere, adjust the position of the protective sleeve.	

2 Installation

2.4.4.1 Fitting attachments of the IRBDP SW6 LI, Lean ID

2.4.4 Installation of IRBDP SW6 LI, LeanID

2.4.4.1 Fitting attachments of the IRBDP SW6 LI, Lean ID

Location of the attachments

The attachments of the cable package are located as shown in the figure.

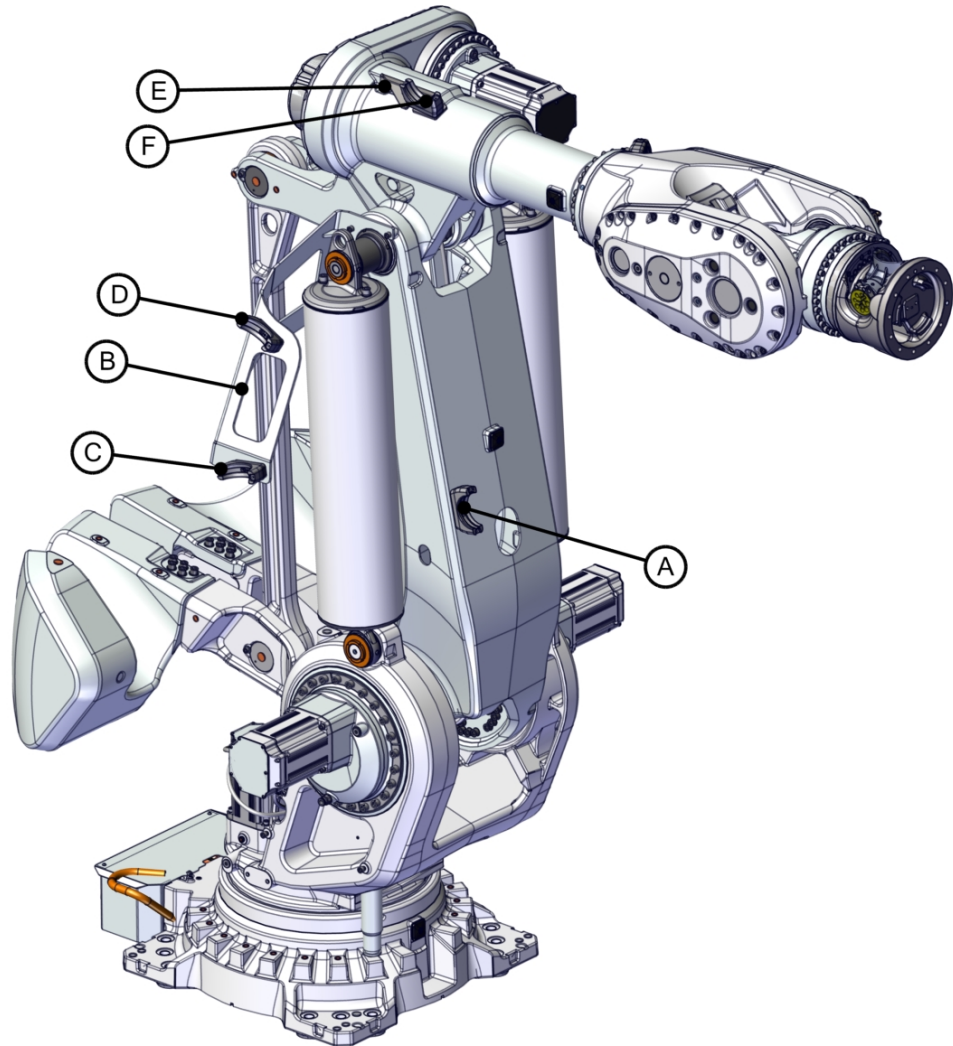

xx1500002597

A	Lower ball joint housing
B	Bracket
C	Lower ball joint housing
D	Lower ball joint housing
E	Bracket
F	Lower ball joint housing

Continues on next page

Required parts

Article	Article number	Note
Material set IRBDP SW6 LI	3HAC055251-001	

Required tools and equipment

Equipment, etc.	Article number	Note
Standard toolkit	-	Content is defined in section Standard toolkit on page 213 .

Consumables

Equipment, etc.	Article number	Note
Locking liquid	-	Loctite 2400 (or equivalent Loctite 243) For locking attachment screws.

Fitting the cable attachments - IRBDP SW6 LI

Use this procedure to fit the cable attachments.

	Action	Note
1	Move the robot to a suitable position for fitting the cable attachments on the lower arm.	
2	 DANGER Turn off all: <ul style="list-style-type: none"> • electric power supply • hydraulic pressure supply • air pressure supply to the robot, before entering the robot working area.	

Continues on next page

2 Installation

2.4.4.1 Fitting attachments of the IRBDP SW6 LI, Lean ID

Continued

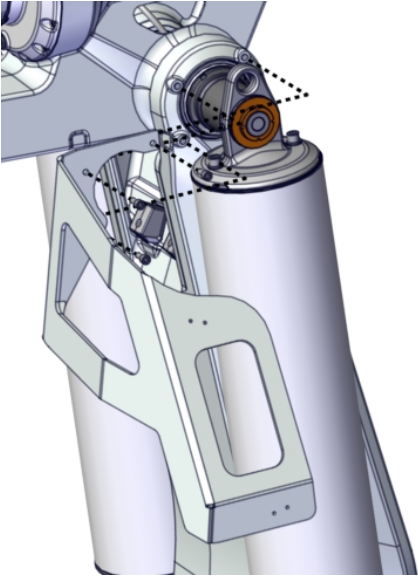
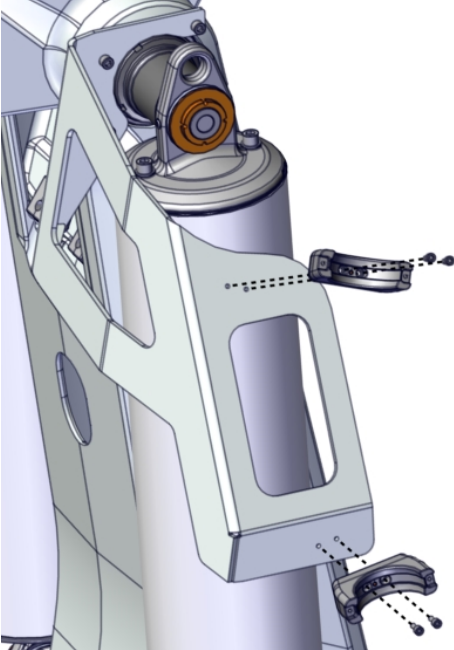
	Action	Note
3	Fasten the bracket on the lower arm. Lock screws with locking liquid.	 <p data-bbox="943 898 1206 958">xx1500002608 M12x25 8.8-A3F (3 pcs)</p>
4	Fasten lower ball joint housings (2 pcs) on the bracket. Lock screws with locking liquid.	 <p data-bbox="943 1637 1190 1697">xx1500002609 M8x16 8.8-A2F (4 pcs)</p>

Continues on next page

2.4.4.1 Fitting attachments of the IRBDP SW6 LI, Lean ID

Continued

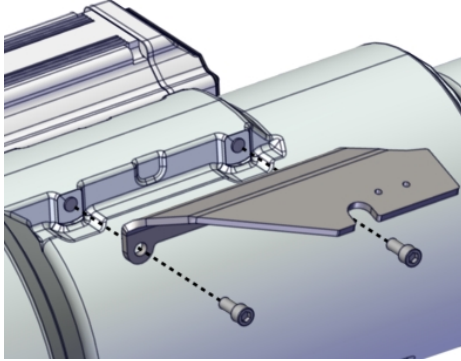
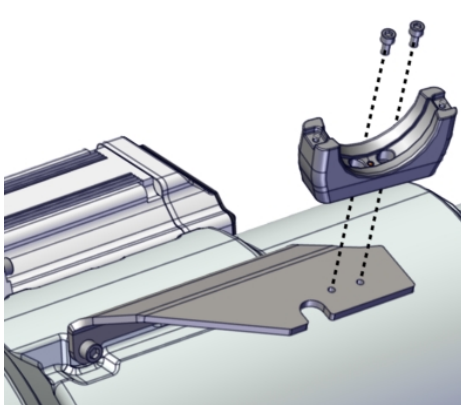
	Action	Note
5	Fasten bracket on axis 4. Lock screws with locking liquid.	 <p data-bbox="970 703 1238 763">xx1500002610 M12x25 8.8-A3F (2 pcs)</p>
6	Fasten lower ball joint housing. Lock screws with locking liquid.	 <p data-bbox="970 1211 1225 1272">xx1500002611 M8x16 8.8-A2F (2 pcs)</p>

Continues on next page

2 Installation

2.4.4.1 Fitting attachments of the IRBDP SW6 LI, Lean ID

Continued

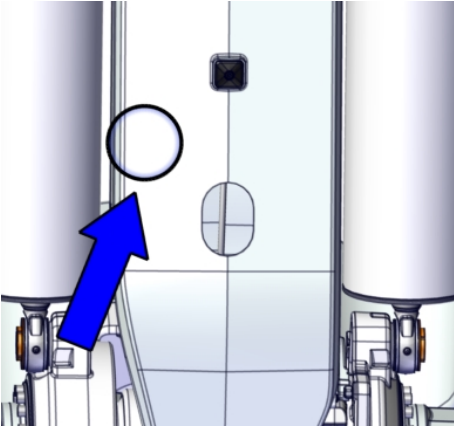
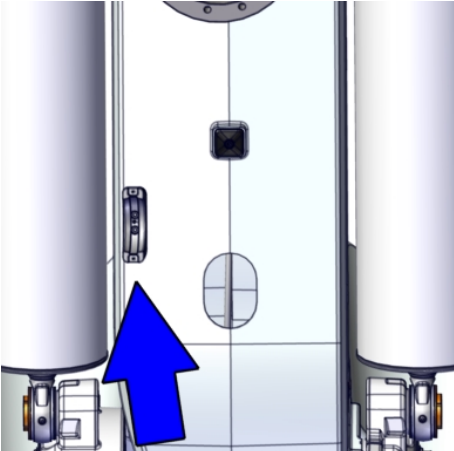
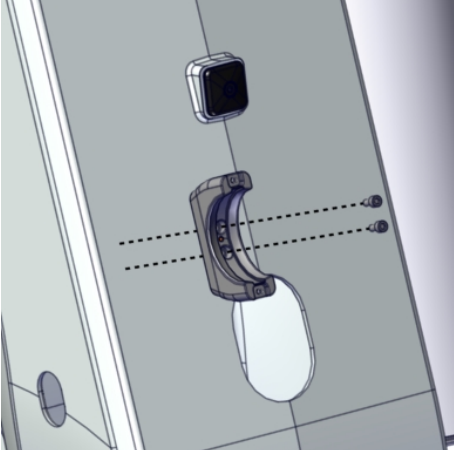
	Action	Note
7	<p>Mark a position on the lower arm where to fasten the lower ball joint housing.</p> <ul style="list-style-type: none">• Use the ball joint housing as a reference template and mark the hole placement (vertical).• Drill and thread the holes for M6 screws.	 <p>xx1500002632</p>  <p>xx1500002633</p>
8	<p>Fasten lower ball joint housing. Lock screws with locking liquid.</p>	 <p>xx1500002635</p> <p>M8x16 8.8-A2F (2 pcs)</p>

2.4.4.2 Fitting the cable package IRBDP SW6 LI, Lean ID

Location of the cable package IRBDP SW6 LI

The DressPack cable package IRBDP SW6 LI, is located as shown in the figure.

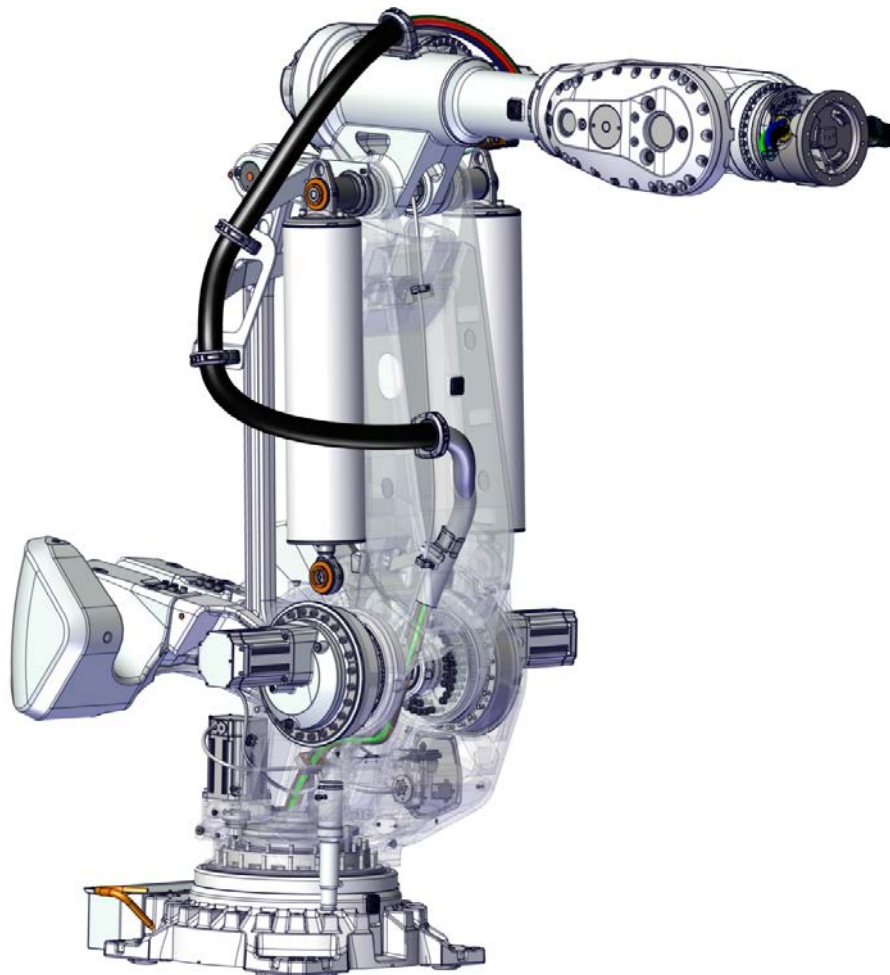

xx1500002651

Spare parts

Spare part	Article number	Note
Cable package IRBDP SW6 LI	See DressPack cable package IRBDP SW6 LI on page 218	

Required tools and equipment

Equipment, etc.	Article number	Note
Standard toolkit, DressPack	-	Content is defined in section Toolkits, DressPack on page 213 .

Continues on next page

2 Installation

2.4.4.2 Fitting the cable package IRBDP SW6 LI, Lean ID

Continued

Required consumable

Equipment, etc.	Art. no.	Note
Locking liquid	-	Loctite 2400 (or equivalent Loctite 243), for locking screws.
Cable grease	3HAC14807-1	Optitemp RB2

Fitting the cable package

Use this procedure to fit the cable package.

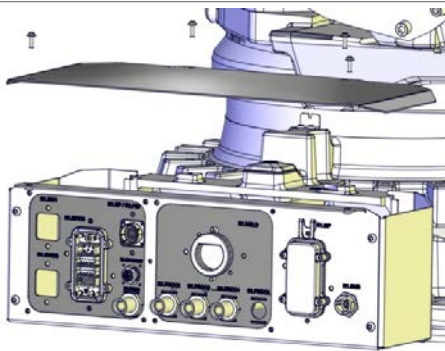

Preparations

	Action	Note
1	Move the robot to a comfortable working position.	
2	 DANGER Turn off all: <ul style="list-style-type: none"> • electric power supply • hydraulic pressure supply • air pressure supply to the robot, before entering the safe-guarded space.	
3	Remove the rear cover plate (if not already removed).	 xx1400000197

Fasten the cable package

	Action	Note
1	 DANGER Turn off all: <ul style="list-style-type: none"> • electric power supply • hydraulic pressure supply • air pressure supply to the robot, before entering the safe-guarded space.	

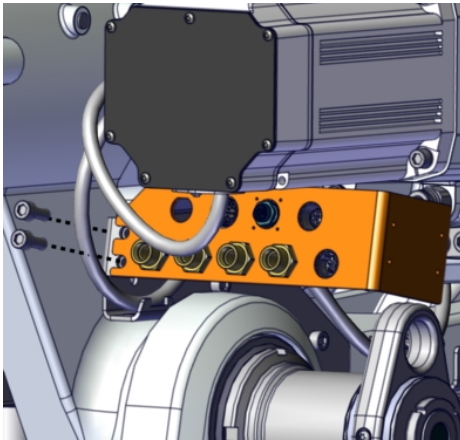
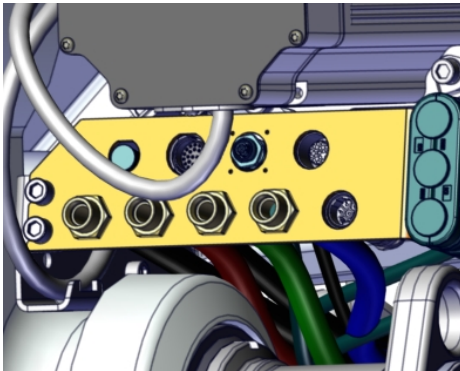
Continues on next page





	Action	Note
2	<p> CAUTION</p> <p>The cable package is sensitive to mechanical damage. Handle it with care in order to avoid damaging the cabling or the connectors.</p>	
3	<p>Start the assembly of the cabling at the connector plate in axis 3-4. Let the cabling rest over the robots axis 3-4.</p>	
4	<p>Fasten the connector plate.</p>	 <p>xx1500002652 M10x25 8.8-A3F (2 pcs)</p>
5	<p>Connect the connectors.</p>	 <p>xx1500003049</p>
6	<p> CAUTION</p> <p>Do not change the position of the clamp inserts on the protection hose, being fitted in the ball joint housings. If the position is changed it will alter the bending movement of the protection hose, when the arms are moved.</p> <p>A change of position of the clamp inserts may result in serious damage to the cable package.</p>	

Continues on next page

2 Installation

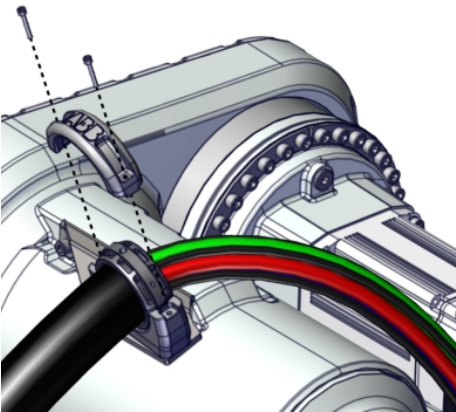
2.4.4.2 Fitting the cable package IRBDP SW6 LI, Lean ID

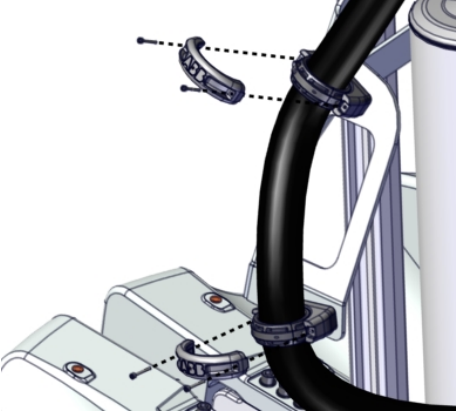
Continued

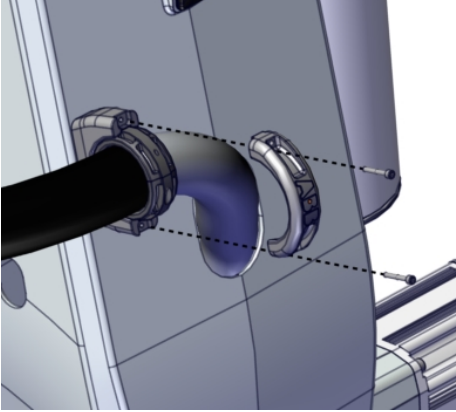
	Action	Note
7	<p>Fasten the cabling in the axis-3 ball joint housing.</p> <p> Note</p> <p>Be careful not to loose the small o-ring! The purpose of the o-ring is to keep the screws in place in the housing, upper part.</p>	 <p>xx1500002653 M8x16 8.8-A2F (2 pcs)</p>
8	<p>Fasten the cabling in the ball joint housings on the lower arm bracket.</p> <p> Note</p> <p>Be careful not to loose the small o-ring! The purpose of the o-ring is to keep the screws in place in the housing, upper part.</p>	 <p>xx1500002654 M8x16 8.8-A2F (2x 2 pcs)</p>
9	<p>Fasten the cabling in the ball joint housings on the lower arm.</p> <p> Note</p> <p>Be careful not to loose the small o-ring! The purpose of the o-ring is to keep the screws in place in the housing, upper part.</p>	 <p>xx1500002658 M8x16 8.8-A2F (2 pcs)</p>

Continues on next page

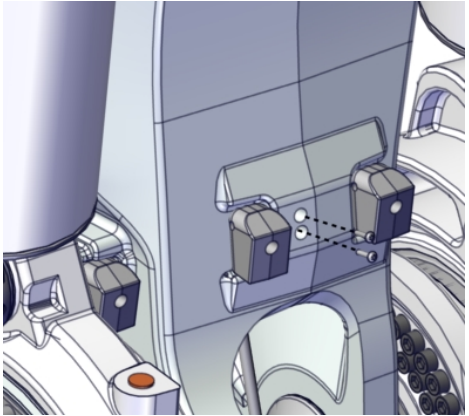
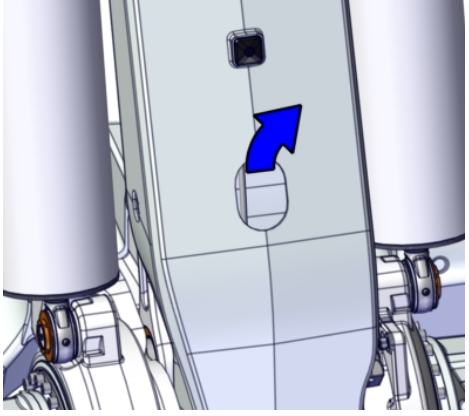
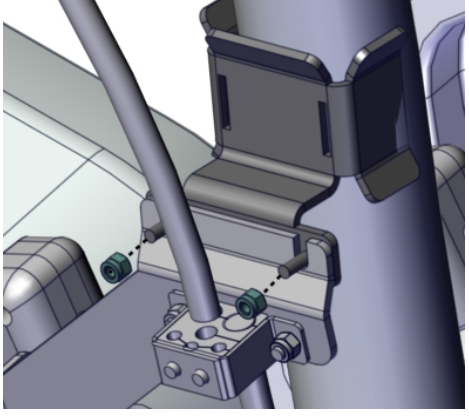
	Action	Note
10	Loosen the screws on the back lower arm. Save the screws for re-assembly.	 <p>xx1500002606</p>
11	Carefully pull out the motor cabling with the bracket through the front hole on the lower arm.	 <p>xx1500002607</p>
12	Fasten the IRBDP SW6 LE cabling bracket on the motor cabling bracket.	 <p>xx1500002655</p> <p>Prev. torque nut M6 (2 pcs)</p>

Continues on next page

2 Installation

2.4.4.2 Fitting the cable package IRBDP SW6 LI, Lean ID

Continued

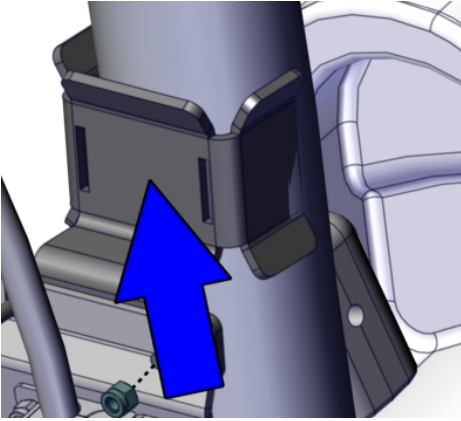
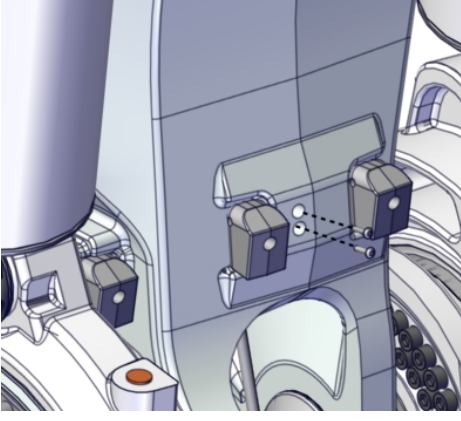
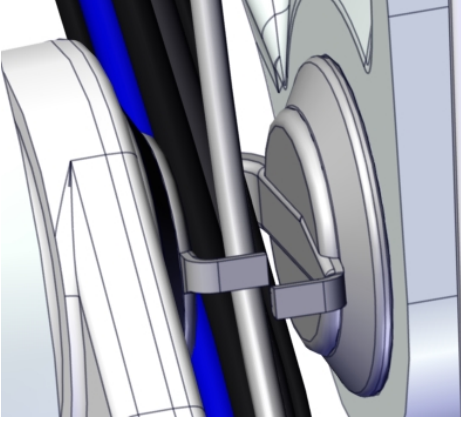

Action	Note
13 Fasten a velcro strap around the bracket and the cabling.	 <p>xx1500002657</p>
14 Carefully push the cabling down through the lower arm.	
15 Fasten the bracket in the back lower arm. Use previously removed screws.	 <p>xx1500002606</p>
16 Put the cabling through the cable guide in axis 2.	 <p>xx1500002656</p>

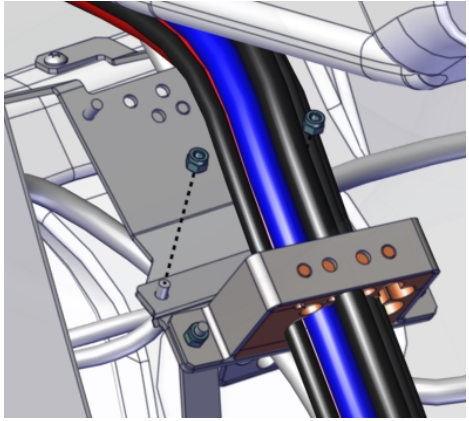
Continues on next page

	Action	Note
17	Fasten the IRBDP cabling on the cabling bracket in the frame.	 <p>xx1500002659</p> <p>Prev. torque nut M6 (2 pcs)</p>
18	Run the cables down through the center hole of axis 1, in the following order: <ul style="list-style-type: none"> • Signal cables (Spot welding) • Hoses • Make a check that cables and hoses do not cross each other. 	

Connect the lower cable package at the base

Connect the lower cable package at the base

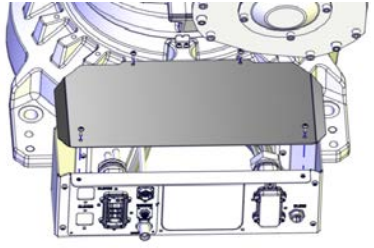
	Action	Note
1	 <p>DANGER</p> <p>Turn off all:</p> <ul style="list-style-type: none"> • electric power supply • air pressure supply <p>to the robot, before starting the repair work on the robot.</p>	
2	 <p>CAUTION</p> <p>The cable package is sensitive to mechanical damage. Handle it with care in order to avoid damaging the cabling or the connectors.</p>	
3	Remove the rear cover plate.	 <p>xx1400000080</p>

Continues on next page



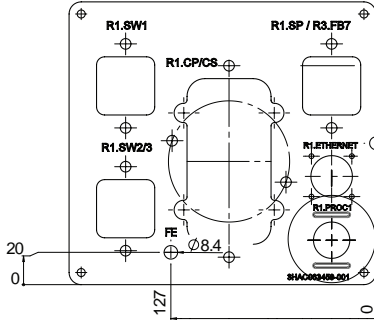
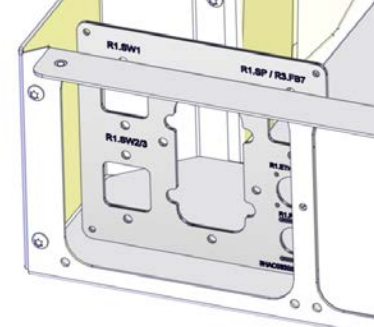
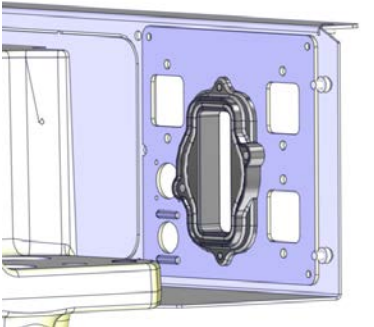
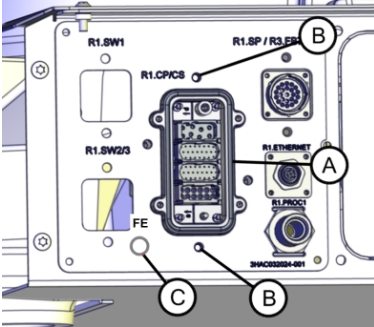

2 Installation

2.4.4.2 Fitting the cable package IRBDP SW6 LI, Lean ID

Continued

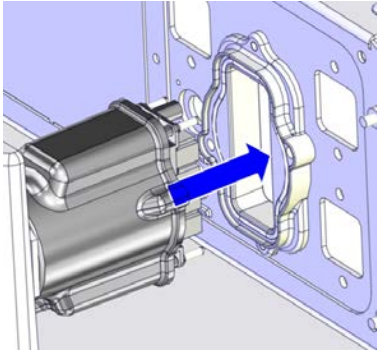
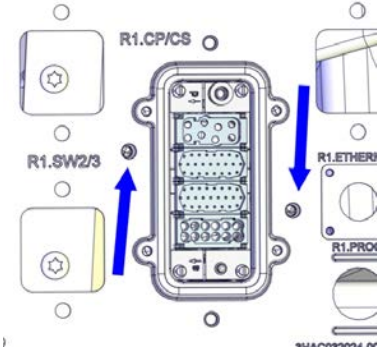
	Action	Note
4	<p>Only for Paramulti DressPack and for spare part replacement.</p> <p>The Paramulti DressPack spare part includes functional ground. If the installed DressPack has not included functional ground previously, following action needs to be done:</p> <p>Drill an 8.4 mm mm hole in the customer plate according to the figure.</p>	 <p>xx1900001268</p>
5	Fit the customer plate.	 <p>xx1400001146</p> <p>M6x16 8.8-A2F (4 pcs)</p>
6	Fit the adapter complete to the customer plate.	 <p>xx1400001140</p>
7	Fasten the adapter complete to the customer plate.	 <p>xx1400001141</p> <p>Parts:</p> <ul style="list-style-type: none"> • A: Adapter complete • B: M6x16 8.8-A2F (2 pcs) • C: Functional ground

Continues on next page

	Action	Note
8	Fit the R1.CP/CS cable to the customer plate.	 <p>xx1400001142</p>
9	Secure the R1.CP/CS connector.	 <p>xx1400001143</p> <p>M6x25 8.8-A2F (2 pcs)</p>
10	<p>Connect the rest of the cable and hose connectors to the customer plate.</p> <p>Only for Paramulti DressPack: Also connect functional ground.</p> <p> CAUTION</p> <p>Do not tighten the brass couplings for water and air with excessive force.</p> <p> CAUTION</p> <p>Make sure that no cables or hoses are twisted or strained. Reroute if necessary.</p> <p> CAUTION</p> <p>If the M12 Ethernet connector is not tightened correctly, there is a risk that the connector can loosen and the cable shield gets disconnected, which will require retightening with the correct torque tools.</p> <p>For secure connection, always tighten at the knurled screw with correct torque and by using proper torque tool, e.g. M12 dynamometric screwdriver SW15 (09 99 000 0646 (article number at Harting Technology Group)).</p>	<p>Tightening torque:</p> <ul style="list-style-type: none"> • Brass coupling 1/2": 31 Nm. • Stainless steel coupling 1/2": 49 Nm. • Brass coupling 3/8": 17 Nm. • Mixed metals: Use the lower tightening torque value of the two metals. <p>Always apply Molykote P1900 to stainless steel couplings and apply if needed for couplings of mixed metals or brass.</p> <p>Tightening torque, Ethernet M12: 0.6 Nm.</p>

2 Installation

2.4.5.1 Fitting attachments of the IRBDP MH6 UI and IRBDP SW6 UI, Lean ID

2.4.5 Installation of IRBDP MH6 UI and IRBDP SW6 UI, LeanID

2.4.5.1 Fitting attachments of the IRBDP MH6 UI and IRBDP SW6 UI, Lean ID

Location of the attachments

The cable package attachments are located as shown in the figure.

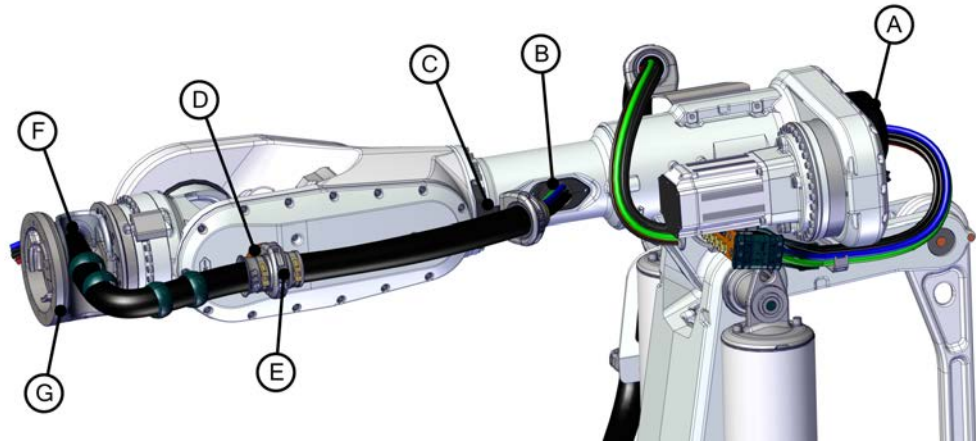

xx1500002766

A	Cover
B	Insert
C	Upper arm bracket
D	Bearing housing
E	Ball joint housing
F	Cable guide
G	Process turning disc

Required parts

Equipment, etc.	Article number	Note
Material set IRBDP SW6 UI and IRBDP MH6 UI	3HAC053942-001	

Required tools and equipment

Equipment, etc.	Article number	Note
Standard toolkit	-	Content is defined in section Standard toolkit on page 213 .

Consumables

Equipment, etc.	Article number	Note
Locking liquid	-	Loctite 2400 (or equivalent Loctite 243)

Continues on next page

Fitting the cable attachments

Use these procedures to fit the cable attachments.

Preparations

	Action	Note
1	Move the robot to a suitable position for fitting the cable attachments on the upper arm.	
2	 DANGER Turn off all: <ul style="list-style-type: none"> • electric power supply • hydraulic pressure supply • air pressure supply to the robot, before entering the safe-guarded space.	

Fitting insert, tube and cover

Use this procedure to fit the insert, the tube and the cover.

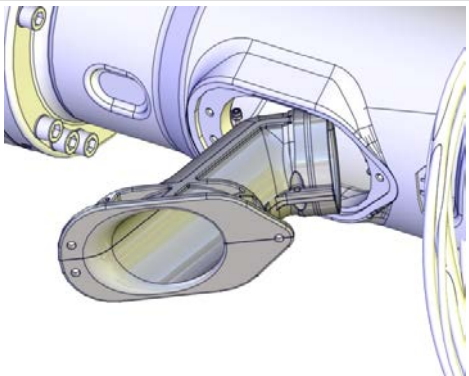
	Action	Note
1	Fit the insert. Lock screws with locking liquid.	 <p>xx140000091 M6x16 Stainless steel A2-70 (3 pcs)</p>

Continues on next page

2 Installation

2.4.5.1 Fitting attachments of the IRBDP MH6 UI and IRBDP SW6 UI, Lean ID

Continued

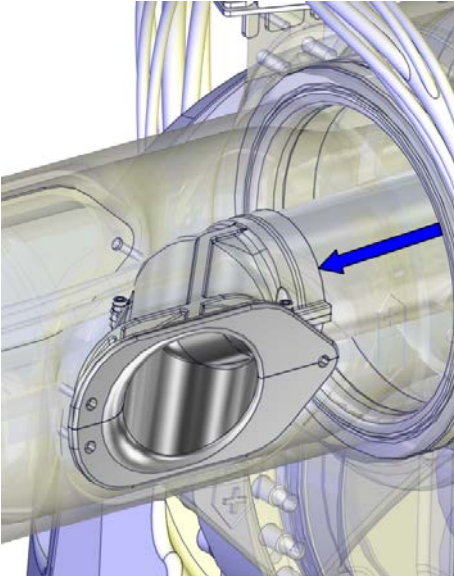
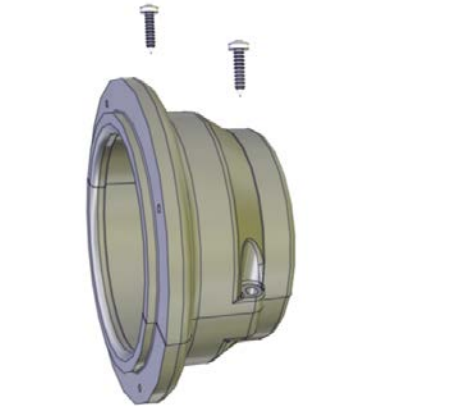
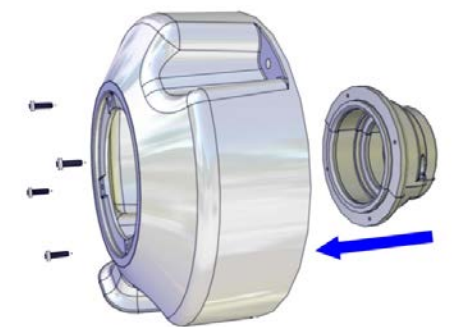
	Action	Note
2	Insert the tube into the arm tube and fit it into the insert.	 <p>xx140000092</p>
3	Mount the two parts of the tube guiding ring.	 <p>xx120000162 ST3.5x16 (2 pcs)</p>
4	Fit the tube guiding ring in the cover.	 <p>xx120000044 ST3.5x16 (4 pcs)</p>

Continues on next page

2.4.5.1 Fitting attachments of the IRBDP MH6 UI and IRBDP SW6 UI, Lean ID

Continued

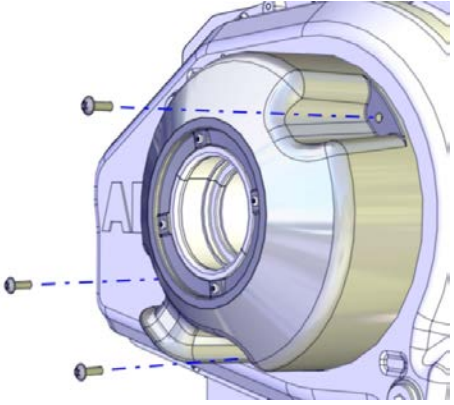
	Action	Note
5	<p>Fit the cover with the tube guiding ring fitted, on the tube and secure it to the arm-house cover. Lock screws with locking liquid.</p> <p> Note</p> <p>Make sure that the tube is fitted correctly in both ends, when fitting the cover.</p>	 <p>xx120000045 M6x16 Stainless steel A2-70 (3 pcs)</p>

Fitting the cable attachments

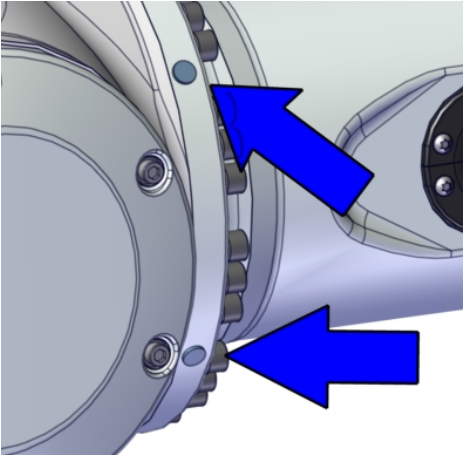
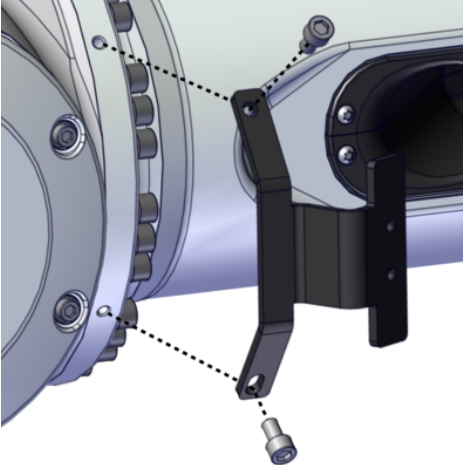
	Action	Note
1	Remove plastic plugs if fitted.	 <p>xx1500002767</p>
2	Fasten the upper arm bracket. Lock screws with locking liquid.	 <p>xx1500002768 M8x16 A2-7 0 (2 pcs)</p>

Continues on next page

2 Installation

2.4.5.1 Fitting attachments of the IRBDP MH6 UI and IRBDP SW6 UI, Lean ID

Continued

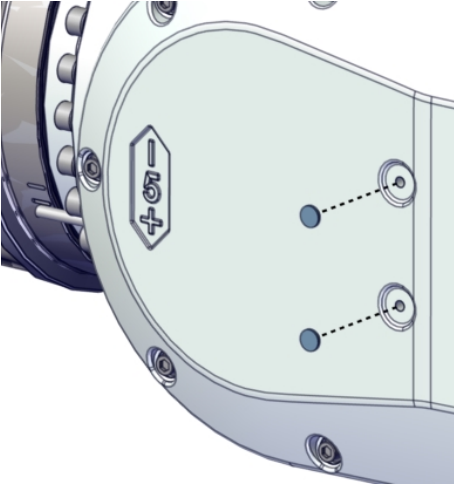
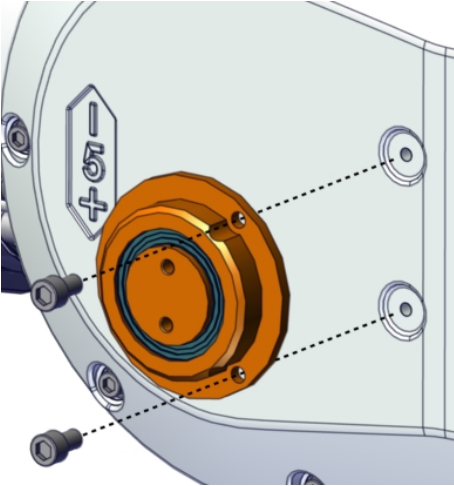
	Action	Note
3	Remove plastic plugs if fitted.	 <p>xx1500002769</p>
4	Fasten bearing with housing. Lock screws with locking liquid.	 <p>xx1500002770 M8x16 A2-7 0 (2 pcs)</p>

Continues on next page

2.4.5.1 Fitting attachments of the IRBDP MH6 UI and IRBDP SW6 UI, Lean ID

Continued

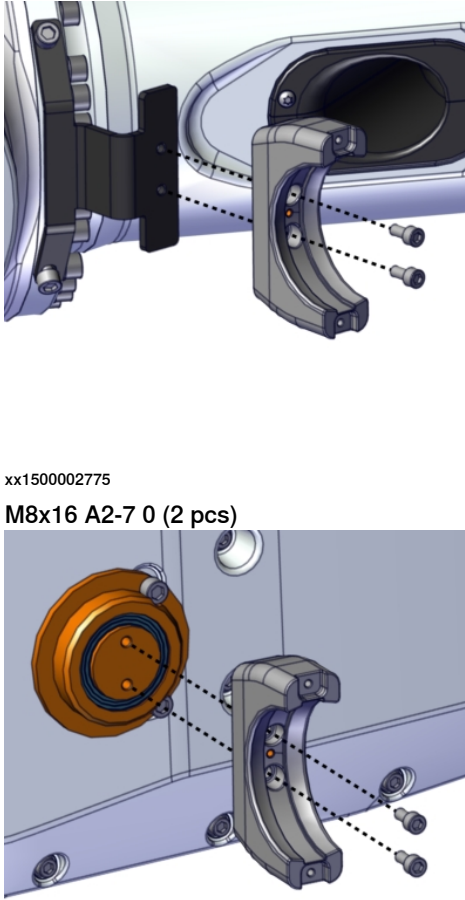
	Action	Note
5	Fasten the two lower ball joint housing parts. Lock screws with locking liquid.	 <p data-bbox="970 779 1082 797">xx1500002775</p> <p data-bbox="970 808 1209 835">M8x16 A2-7 0 (2 pcs)</p> <p data-bbox="970 1305 1082 1323">xx1500002776</p> <p data-bbox="970 1335 1209 1361">M8x16 A2-7 0 (2 pcs)</p>

2 Installation

2.4.5.2 Fitting the cable packages IRBDP MH6 UI and IRBDP SW6 UI, Lean ID

2.4.5.2 Fitting the cable packages IRBDP MH6 UI and IRBDP SW6 UI, Lean ID

Location of the cable package IRBDP SW6 UI and IRBDP MH6 UI

The cable packages IRBDP SW6 UI and IRBDP MH6 UI, are located as shown in the figure. The figure shows cable package IRBDP SW6 UI. The principle of IRBDP MH6 UI is the same as IRBDP SW6 UI.

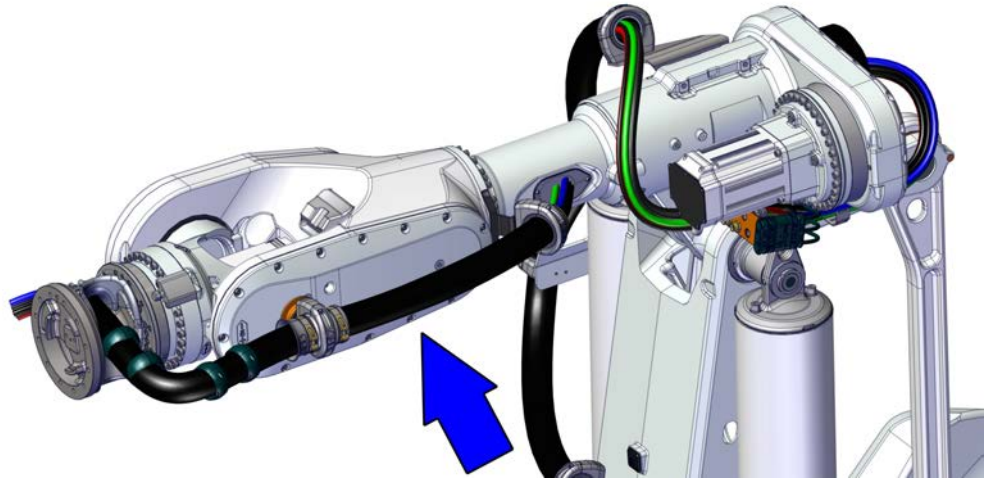

xx1500002777

Required parts

Equipment, etc.	Article number	Note
Cable package IRBDP SW6 UI	See DressPack cable package IRBDP SW6 UI on page 219	
Cable package IRBDP MH6 UI	See DressPack cable package IRBDP SW6 UI on page 218	

Required tools and equipment

Equipment, etc.	Article number	Note
Standard toolkit, DressPack	-	Content is defined in section Toolkits, DressPack on page 213 .

Consumables





Equipment, etc.	Article number	Note
Locking liquid	-	Loctite 2400 (or equivalent Loctite 243)
Cable grease	3HAC14807-1	Optitemp RB2

Continues on next page

Fitting the cable package - IRBDP SW6 UI and IRBDP MH6 UI

Use these procedures to fit the cable packages.

Route the cable package

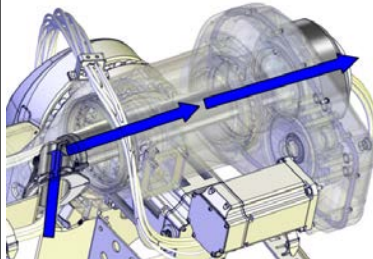
	Action	Note
1	Move the robot to a comfortable working position.	
2	 DANGER Turn off all: <ul style="list-style-type: none"> • electric power supply • hydraulic pressure supply • air pressure supply to the robot, before entering the safeguarded space.	
3	 CAUTION The cable package is sensitive to mechanical damage. Handle it with care in order to avoid damaging the cabling or the connectors.	
4	 Tip This procedure is best done by two persons working together - one pushing cabling and hoses into the tube and the other pulling them out at the wrist.	
5	Carefully push the cable package into the insert, through the tube and out in the back of the arm housing.  Tip The following order is preferable: <ol style="list-style-type: none"> 1 Cables 2 Hoses 3 Weld cables (where applicable) If there is a problem, remove the nut inside the tube.	 <small>xx140000095</small>

Apply cable grease

It is necessary to apply cable grease on the cable package inside the tube.



	Action	Note
1	Carefully pull the cable package out 10 to 15 centimeters longer than the final assembly position.	

Continues on next page

2 Installation

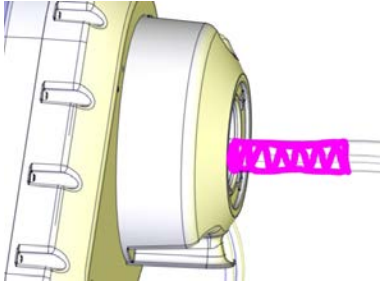
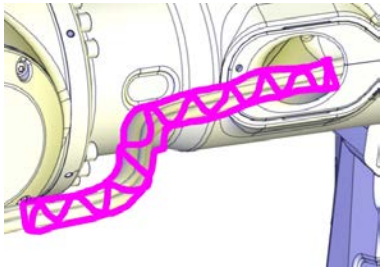

2.4.5.2 Fitting the cable packages IRBDP MH6 UI and IRBDP SW6 UI, Lean ID

Continued

	Action	Note
2	Apply grease on the highlighted area.	 xx1400001389
3	Carefully push the cable package back into the tube and out through the insert until the area where grease was applied, is visible and able to reach.	
4	Apply grease on the highlighted area so that the cable package inside the tube is covered with cable grease all the way through.	 xx1400001390
5	Carefully push the cable package back in through the insert and into its mounting position in the tube.	
6	 Note Make sure the cables and hoses are not twisted through the upper arm.	

Continues on next page

Connect the cable package

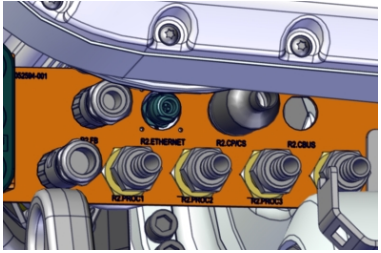
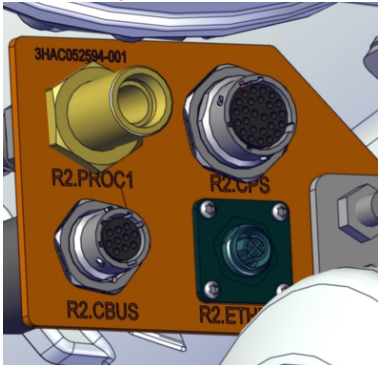
	Action	Note
1	<p>Connect the hose and cable connectors on the connection plate.</p> <p> CAUTION</p> <p>Do not tighten the brass couplings for water and air with excessive force.</p> <p> Tip</p> <p>Start connecting top connectors, and continue downwards.</p> <p> CAUTION</p> <p>If the M12 Ethernet connector is not tightened correctly, there is a risk that the connector can loosen and the cable shield gets disconnected, which will require retightening with the correct torque tools.</p> <p>For secure connection, always tighten at the knurled screw with correct torque and by using proper torque tool, e.g. M12 dynamometric screwdriver SW15 (09 99 000 0646 (article number at Harting Technology Group)).</p>	<p>Tightening torque:</p> <ul style="list-style-type: none"> • Brass coupling 1/2": 31 Nm. • Stainless steel coupling 1/2": 49 Nm. • Brass coupling 3/8": 17 Nm. • Mixed metals: Use the lower tightening torque value of the two metals. <p>Always apply Molykote P1900 to stainless steel couplings and apply if needed for couplings of mixed metals or brass.</p> <p>Tightening torque, Ethernet M12: 0.6 Nm.</p> <p>SW-cabling:</p>  <p>xx1500002812</p> <p>MH-cabling:</p>  <p>xx1500003038</p>

Continues on next page

2 Installation

2.4.5.2 Fitting the cable packages IRBDP MH6 UI and IRBDP SW6 UI, Lean ID

Continued

Weld connector

Only valid for IRBDP SW6 UI.

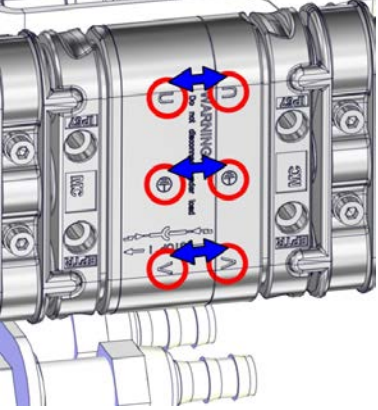
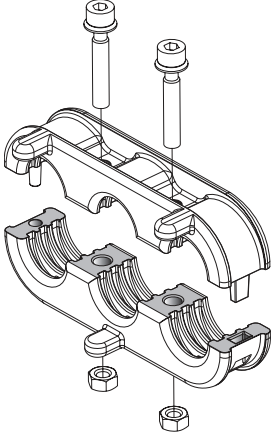
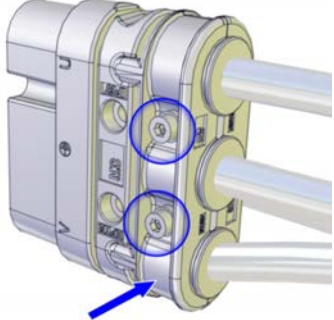
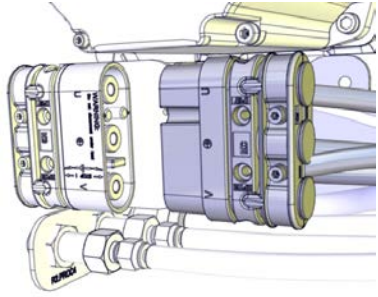
	Action	Note
1	<p>Press (manually) the cables with the crimped-on contact part into the insulation from the back until it perceptibly engages into place to the detent.</p> <p> Note</p> <p>Make sure the pins are pushed all the way into the connector.</p>	 <p>xx1400000216</p>
2	<p>Fit the cable strain relief.</p>  <p>xx1300000836</p>	 <p>xx1200000058</p> <p>M5x25 8.8-A2F (2 pcs)</p>
3	<p>Connect the weld cable.</p>	 <p>xx1200000075</p>

Continues on next page

2.4.5.2 Fitting the cable packages IRBDP MH6 UI and IRBDP SW6 UI, Lean ID

Continued

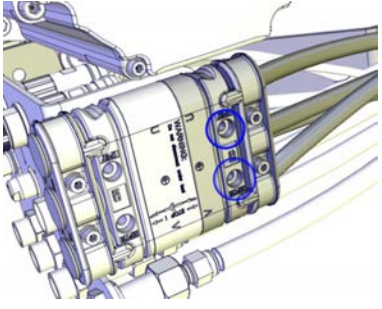
	Action	Note
4	Fasten the weld connector to the connection plate.	 <p data-bbox="1059 622 1166 640">xx120000089</p> <p data-bbox="1059 651 1310 680">M5x40 8.8-A2F (2 pcs)</p>

Fasten the cable package IRBDP SW6 UI and IRBDP MH6 UI

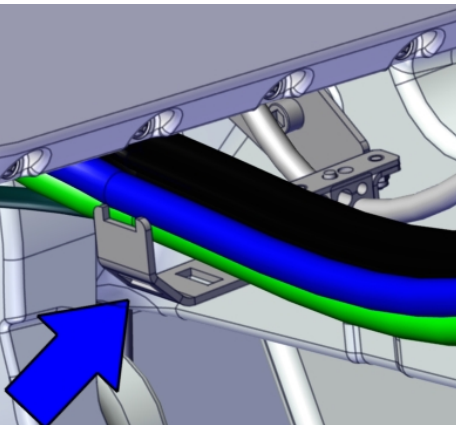
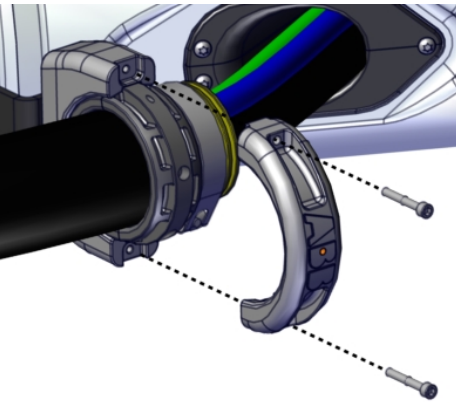

	Action	Note
1	Fasten the cable package to the bracket with a strap.	 <p data-bbox="975 1240 1082 1258">xx1500002818</p>
2	Fasten the cable package in the ball joint housing.	 <p data-bbox="975 1715 1082 1733">xx1500002819</p> <p data-bbox="975 1744 1209 1774">M8x16 A2-7 0 (2 pcs)</p>

Continues on next page

2 Installation

2.4.5.2 Fitting the cable packages IRBDP MH6 UI and IRBDP SW6 UI, Lean ID

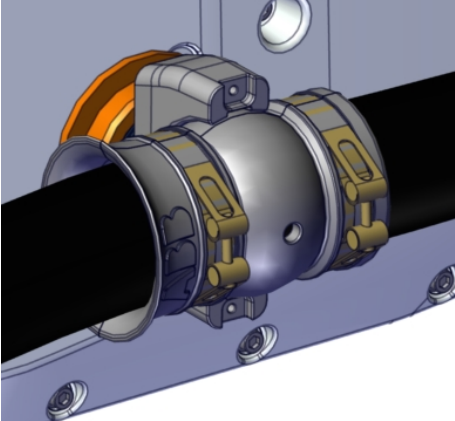

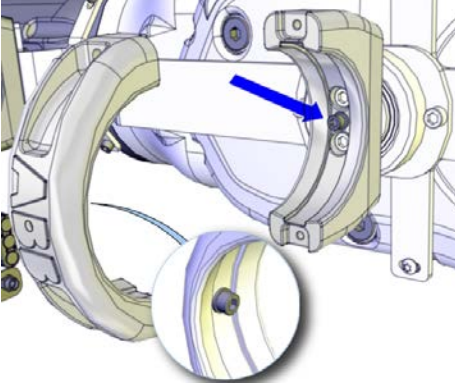
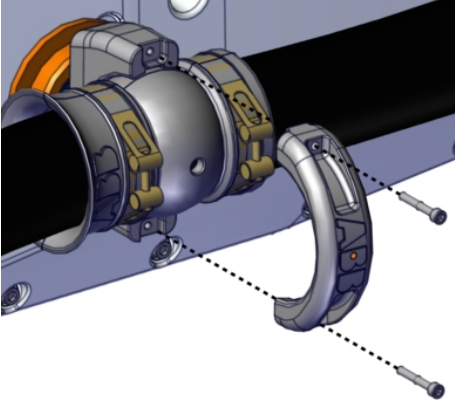
Continued

	Action	Note
3	<p>Make sure that the hose reinforcement funnel is fitted correctly, in the direction shown in the figure.</p>	 <p>xx1500002821</p>
4	<p>Make sure that the screws (M6x12) fits into the guiding holes of the hose reinforcement funnel when it is fitted in the ball joint housing.</p> <p> CAUTION</p> <p>The hose reinforcement funnel must not be able to rotate inside the ball joint housing when fitted.</p>	 <p>xx1200000153</p> <p>M6x12 8.8-A2F (1 pc)</p>
5	<p>Fasten the cable package in the ball joint housing.</p>	 <p>xx1500002820</p> <p>M8x16 A2-7 0 (2 pcs)</p>
6	<p>Only valid for IRBDP SW6 UI: Put cable grease on the process turning disc and the cable guide.</p>	<p>Cable grease 3HAC14807-1</p>

Continues on next page

2.4.5.2 Fitting the cable packages IRBDP MH6 UI and IRBDP SW6 UI, Lean ID

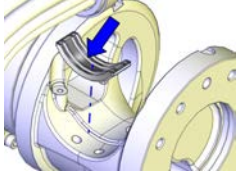
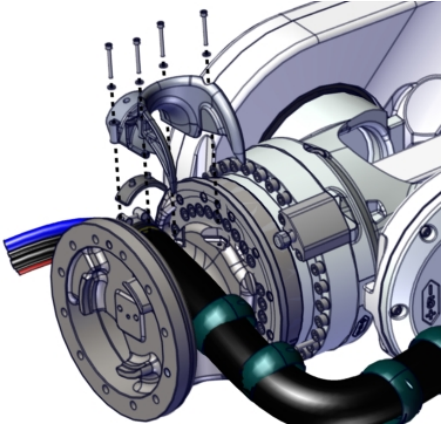
Continued

	Action	Note
7	<p>Only valid for IRBDP SW6 UI: Fasten the cable package in the clamp jaw with the process turning disc cable guide.</p>  <p>xx1400000223</p>	 <p>xx1500002822</p>
8	<p> CAUTION</p> <p>Check potential collision risks between the cable package and the wrist, as well as between the cable package and any equipment fitted on the wrist, before restarting the normal production.</p>	
9	<p>Turn on the power and run the present programming at a very slow speed, while checking all movements for collision risk between cable package and wrist.</p>	
10	<p> DANGER</p> <p>Make sure all safety requirements are met when performing the first test run. See Test run after installation, maintenance, or repair on page 116.</p>	

Continues on next page

2 Installation

2.4.5.2 Fitting the cable packages IRBDP MH6 UI and IRBDP SW6 UI, Lean ID

Continued

Check of protective sleeve

The protective hose is protected against wear in exposed areas with a protective sleeve.

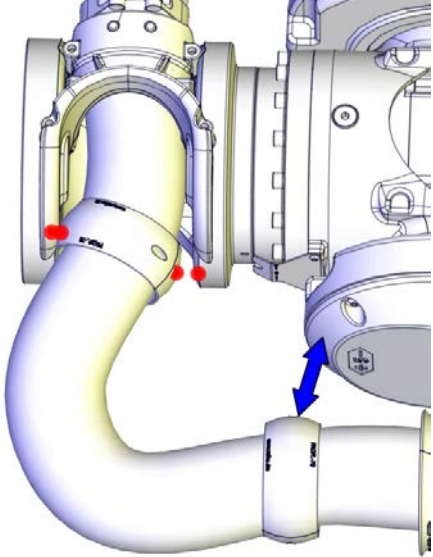
	Action	Note
1	In order to be sure that the protective sleeve is in the correct position, check the position after some hours running.	 <p>xx1400000224</p>
2	If the protective hose is worn somewhere, adjust the position of the protective sleeve.	

2.5 Inspection, DressPack lower arm

General

In order to ensure adequate life of the equipment, it is vital that the cables and hoses are properly installed and operated correctly, with their movement patterns well within the acceptable limits.

This procedure describes how to inspect the DressPack lower arm installation in this regard.

Inspecting the process cable package

	Action	Note
1	<p><i>Do not bend</i> any cable or hose excessively!</p>  Note Make sure no cables or hoses are twisted.	Minimum bending radius is approximately 10x the cable or hose diameter.
2	Make sure all cables straps are tight enough to prevent the cable package from moving in any undesired way.	
3	Make sure the cable package is properly connected at the connection plate as well as at the robot base.	
4	Make sure no hoses or cables, or parts thereof, touch any part of the robot structure in a way that may cause wear.	
5	Make sure all cables and hoses move smoothly together during operation and that no part of the cable package moves in a different pattern.	
6	Make sure that cables, hoses or packages do not rub against <i>any sharp corner of something</i> (not just the robot itself)!	
7	Make sure all connection points are well tightened and sealed in order to avoid leaks.	

Inspecting the attachments and brackets

	Action	Note
1	Make sure that all cable clamps securing the process cable package and protective hose are tightened correctly.	Tightening torques are specified: <ul style="list-style-type: none"> • For <i>standard tightening torques</i> - See tightening torque table in chapter References. • For <i>non standard tightening torques</i> see chapter <i>Installation</i>.

2 Installation

2.6 Inspection, DressPack upper arm

2.6 Inspection, DressPack upper arm

Introduction

In order to ensure adequate life of the equipment, it is vital that the cables and hoses are properly installed and operated correctly, with their movement patterns well within the acceptable limits.

This section describes how to inspect the DressPack upper arm installation in this regard.

Procedure, general

	Action	Note
1	Inspect all attachments, brackets and any other hardware securing or guiding the protective hose.	
2	Inspect the process cable package.	Described in the following section.
3	Inspect and make sure all cables and hoses are securely fixed and connected.	Described in the following section.

Cables and hoses

Use this procedure to inspect cables and hoses, not necessarily in any particular order unless stated.

	Action	Note
1	Do not bend any cable or hose excessively.	Minimum bending radius is approximately 10x the cable or hose diameter.
2	Make sure no cables or hoses are twisted.	
3	Make sure that all hoses and cables to gun or gripper are long enough to avoid stretching.	
4	Make sure that the protection hose is rotating correctly in the hose reinforcement funnel.	
5	Make sure that the hose reinforcement funnel is tilting correctly in the ball joint housing.	
6	Make sure that cables are clamped with straps in a way that there is no movement at connectors.	Use only wide straps or velcro straps in order not to damage the cables or hoses.
7	Make sure that no hoses or cables, or parts thereof, touch any part of the robot structure in a way that may cause wear.	
8	Make sure that no hoses or cables, or parts thereof, touch any part of the surrounding equipment in a way that may cause wear.	
9	Make sure all cables and hoses move smoothly together during operation.	

Continues on next page

Securing and connecting

Use this procedure inspect the securing and connecting of the cable harness, not necessarily in any particular order unless stated.

	Action	Note
1	Make sure that all cable clamps securing the process cable package and protective hose are tightened correctly.	Tightening torques are specified: <ul style="list-style-type: none"> • For <i>standard tightening torques</i> - See tightening torque table in chapter References. • For <i>non standard tightening torques</i> - See Installation chapter.
2	Make sure all cable straps are tight enough to prevent the cable package from moving in any undesired way.  Note The cable ties should not be too narrow. This may damage the cables/hoses.	
3	When securing cables and hoses with cable ties: <i>never</i> overtighten the ties. It may damage the equipment.	
4	Make sure that the cable package have been properly connected at the connection plate, axis 3 on the rear of the upper arm as well as at the tool on the robot turning disc.	
5	Make sure all connection points are well tightened and sealed in order to avoid leaks.	
6	Make sure the weight of the cable package is secured to the tool in order to avoid straining the connectors.	

2 Installation

2.7.1 Inspection during programming and test-running

2.7 DressPack adjustments

2.7.1 Inspection during programming and test-running

General

In order to ensure adequate life of the equipment, it is vital that the cables and hoses are properly installed and operated correctly, with their movement patterns well within the acceptable limits.

Checking the cable package at the upper arm

This procedure describes how to inspect the DressPack upper arm installation during programming and test-running the complete installation the very first times.

IRBDP MH3 UI, IRBDP MH6 UI, IRBDP SW6 UI

This instruction describes how to inspect the DressPack installation during programming and test-running the complete installation the very first times.

	Action	Note
1	Inspect the DressPack upper arm installation before programming and test-running.	See Inspection, DressPack upper arm on page 90 .
2	Check the operating cycle of the robot, to make sure the movement pattern of the wrist does not cause extensive wear or strain of the cable package.	If required, re-program the robot movement pattern!
3	Make sure the upper arm protective hose <i>does not get flattened</i> during rotating upper arm movements.	Flattening indicates an overstressed hose and <i>increases</i> the risk of damaging the DressPack upper arm.
4	Make sure the process cable package does not rub against the sides of the wrist more than absolutely necessary.	The rubbing may result in the cable getting stuck. When the package is released, the retracting unit may snap back, potentially causing damage to the equipment.
5	If any of the actions recommended above, causes a change of the DressPack installation, it must be reinspected.	See section Inspection, DressPack upper arm on page 90 .
6	Make sure that the velcro straps are not too tight. The cables should be able to twist individually. The cable ties shall be tight.	
7	Make sure that no parts of the DressPack are in contact with the surroundings.	

Checking the DressPack at the lower arm

This instruction describes how to inspect the DressPack lower arm installation during programming and test-running the complete installation the very first times.

	Action	Note
1	Inspect the DressPack lower arm installation before programming and test-running.	See section Inspection, DressPack lower arm on page 89

Continues on next page

2.7.1 Inspection during programming and test-running

Continued

	Action	Note
2	Check the operating cycle of the robot, to make sure the movement pattern of the robot does not cause extensive wear or straining on the cable package.	If required, re-program the robot movement pattern!
3	If any of the actions recommended above, causes changes of the DressPack lower arm installation, it must be reinspected.	See section Inspection, DressPack lower arm on page 89

2 Installation

2.8.1 DressPack - arm load parameters and LoadId

2.8 DressPack arm load parameters

2.8.1 DressPack - arm load parameters and LoadId

General

A DressPack is adding load to the robot. If the arm and tool loads are not stated correctly, this will affect the behavior and the wear of the robot.



Note

The extra weight of the DressPack products will affect the arm load data and the performance of the robot. The effect differs depending on which type of DressPack product being used.

Coordinate system definitions

Coordinate system definitions when defining arm loads.

Arm load parameters for spot welding



Note

These values reflect the standard mounting of the Process bracket, pointing straight upwards in the robot calibration position. If the mounting is changed, the X, Y and Z values must be changed correspondingly.

Arm load parameters for material handling



Note

These values reflect the standard mounting of the Process bracket, pointing straight upwards in the robot calibration position. If the mounting is changed, the X, Y and Z values must be changed correspondingly.

Procedures Step 1 - Arm load data

How to define the *Arm load* data is described in *Operating manual - IRC5 with FlexPendant*.

All system parameters are described in *Technical reference manual - System parameters*.

Define the arm loads, typically:

- load:_1
- load:_2
- load:_3

The used arm load is defined for each arm, irb_1, irb_2, and irb_3.

Continues on next page

Procedures Step 2 - load identification

It is recommended to use the load identification service routine to define the load data for an individual robot, as this method not only measures the mass but also the inertia of the tool.

Detailed in *Operating manual - IRC5 with FlexPendant*.

	Action	Note
1	Check if the cable package prevents movements.	If the cable package prevent the motions.
2	If not: Run the load identification service routine.	The DressPack forces on the wrist will "increase" the load parameters, but this is anyhow a good approximation of the actual load case to be considered by the motion planning functions of the robot.
3	If the cable package prevent the motions: Remove the cable package.	
4	Make the load identification.	
5	Refit the cable package.	
6	Add the DressPack load manually.	See Procedures Step 1 - Arm load data on page 94 .

2 Installation

2.9.1 Installation of DressPack floor

2.9 DressPack floor

2.9.1 Installation of DressPack floor

Configuration and connections of DressPack floor

The DressPack floor is made up of several components. Some of these components are specific to DressPack application, while others are used also in other applications.

The configuration of the components differs between different application types.

Types of application

Some typical applications are specified below:

Type of application	Description	Example of included components
H		Robot, single cabinet controller
S	Pneumatic gun	Robot, single cabinet controller
HS	Material handling and pneumatic gun	Robot, single cabinet controller, pedestal gun
Se	Servo gun	Robot, single cabinet controller
HSe	Material handling and servo gun	Robot, single cabinet controller, pedestal gun

Connection points

The cables and connections points between the components are all detailed and illustrated in the circuit diagram for the current application. See references to the circuit diagrams in [References on page 8](#).

Required equipment

Equipment, etc.	Article number	Note
DressPack floor	For spare part number see chapter: <ul style="list-style-type: none">Spare parts on page 217.	A number of versions are available.
M12 torque screwdriver and M12 assembly tool (bit)	TSD 04 SAC (article number at Phoenix Contact) SAC BIT M12-D15 (article number at Phoenix Contact)	Order both parts and assemble. The screwdriver has a preset torque of 0.4 Nm. Used to tighten M12 Ethernet connectors.  xx2200001262
Standard toolkit	3HAC17290-7	The contents are defined in section Toolkits, DressPack on page 213 .



Continues on next page

Reference documents

Document	Document number	Note
<i>Circuit diagram - DressPack for spotwelding SWC IRC5 M2004</i>	3HAC026208-001	Valid for all robots without PROFINET.
<i>Circuit diagram - DressPack SWC IRC5 Design 2014 PROFINET</i>	3HAC044736-001	Valid for all robots with option 782-13 Bosch MFDC PROFINET.

Installation

The procedure below details how to install the DressPack floor. Also refer to the current circuit diagram according to [References on page 8](#) and the [Spare parts on page 217](#) chapter.

	Action	Note
1	 DANGER Turn off all: <ul style="list-style-type: none"> • electric power supply • hydraulic pressure supply • air pressure supply to the robot, before entering the safe-guarded space.	
2	 CAUTION The cable package is sensitive to mechanical damage. Handle it with care in order to avoid damaging the cabling or the connectors.	
3	Determine which type of installation is to be done. Study the circuit diagram to decide which cables to connect.	The different types are shown in section Configuration and connections of DressPack floor on page 96 .
4	Whenever possible, run all cables/hoses in cable ducts or trenches. Make sure these meet the required standards.	Make sure: <ul style="list-style-type: none"> • no floor weld cable is routed along signal cabling to minimize the risk of interference. • the duct/trench floor is free from sand and other contamination. This is to reduce the risk of damaging the cable insulation. • no cables or hoses rub against any sharp corners which might damage them.
5	Do not bend or twist any cable or hose excessively.	Minimum bending radius is approximately 10x the cable or hose diameter.
6	Make sure all cable straps are tight enough to prevent the cable package from moving in any undesired way.	

Continues on next page

2 Installation

2.9.1 Installation of DressPack floor

Continued

	Action	Note
7	Remember that switching the weld power as well as the water ON and OFF may cause the cables/hoses to move slightly. They may require additional clamping to avoid damage caused by these movements.	
8	Connect the shop power supply to the spot welding cabinet.	The supply needs to be configured in such a way that the requirements of the spot welding cabinet are met: <ul style="list-style-type: none"> • Voltage: 400-600 VAC, 50-60 Hz • Fuse: 110 A • Earth fault protection, see <i>Product manual - Spot welding cabinet IRC5 (3HAC058524-001)</i>. • Contactor, see <i>Product manual - Spot welding cabinet IRC5 (3HAC058524-001)</i>.
9		See circuit diagram and the Spare parts on page 217 chapter.
10	Select which CP/CS cabling (customer power/customer signals) to be used.	Some versions include industrial buses. See circuit diagram and the Spare parts on page 217 chapter.
11	<p>Connect the CP/CS cable to the manipulator and controller cabinet connectors.</p> <p> Note</p> <p>If the M12 Ethernet/PROFINET connector is not tightened correctly, there is a risk that the connector can loosen and the cable shield gets disconnected, which will require retightening with the correct torque tools. For secure connection, always tighten with correct torque and by using proper torque tool, with a preset torque of 0.4 Nm.</p> <p>Example for Phoenix connectors: assembly tool SAC BIT M12-D15 and torque screwdriver TSD 04 SAC.</p> <p>Example for Harting connectors: M12 dynamometric screwdriver SW15.</p>	<p>See circuit diagram and the Spare parts on page 217 chapter.</p> <p>Tightening torque, Ethernet/PROFINET M12: 0.4 Nm.</p>
12	If used, connect the split box cable to the water and air unit on the robot and to the spot welding cabinet (if no PROFINET is available) or to the single cabinet controller (if PROFINET is available) <i>connectors</i> .	See circuit diagram and the Spare parts on page 217 chapter.
13	If used, connect the stationary/pedestal gun process cable to the stationary/pedestal gun connectors and to the spot welding cabinet (if no PROFINET is available) or to the single cabinet controller (if PROFINET is available).	A stationary/pedestal gun is optional. See circuit diagram and the Spare parts on page 217 chapter.
14	If used, connect the functional ground cable to the robot base and to the spot welding cabinet.	See circuit diagram.

Continues on next page

	Action	Note
15	If used, connect the weld power cable to the spot welding cabinet and to the robot or the stationary/pedestal gun (depending on if it is variant <i>Se</i> or <i>HSe</i>).	See circuit diagram and the Spare parts on page 217 chapter.
16	If used, connect the resolver cable to the robot base and to the stationary/pedestal gun.	See circuit diagram and the Spare parts on page 217 chapter.

2 Installation

2.9.2 Inspection, DressPack floor

2.9.2 Inspection, DressPack floor

General

In order to ensure adequate life of the equipment, it is vital that the cables and hoses are properly installed and operated correctly, with their movement patterns well within the acceptable limits.

This instruction details how to inspect the DressPack floor installation in this regard.

Procedure, process cable package

This section details each inspection to be carried out, not necessarily in any particular order unless stated.

	Action	Note
1	Make sure that the cable package is properly connected at the robot base as well as at the other end.	
2	Make sure that no hoses or cables, or parts thereof, are routed in such a way that they are subjected to wear, for example hoses being run over by fork lifts etc.	
3	Make sure that no cables or hoses rub against any sharp corners which might damage them.	
4	<p>Make sure all connection points are well tightened and sealed in order to avoid leaks.</p> <p> Note</p> <p>If the M12 Ethernet/PROFINET connector is not tightened correctly, there is a risk that the connector can loosen and the cable shield gets disconnected, which will require retightening with the correct torque tools. For secure connection, always tighten with correct torque and by using proper torque tool, with a preset torque of 0.4 Nm.</p> <p>Example for Phoenix connectors: assembly tool SAC BIT M12-D15 and torque screwdriver TSD 04 SAC.</p> <p>Example for Harting connectors: M12 dynamometric screwdriver SW15.</p>	Tightening torque, Ethernet/PROFINET M12: 0.4 Nm.

2.10 Water & Air unit

2.10.1 Installation of Water and air unit

Location of the Water and Air unit

The Water and Air unit is located on top of the robot base.

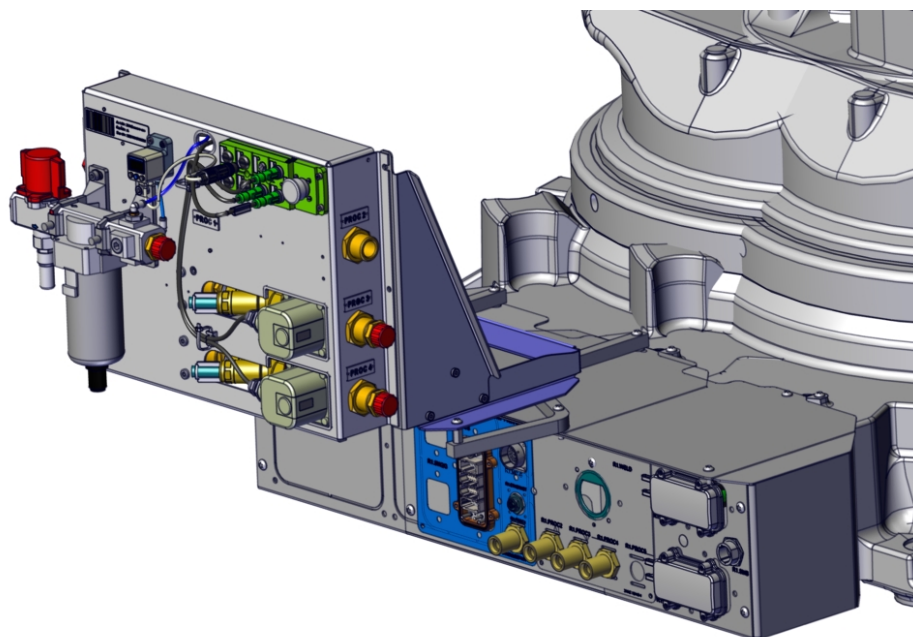

General technical data

The table below shows technical data of the water and air pressure:

Parameter	Value
Water operating pressure	Max. 0.6 MPa / 87 PSI
Air operating pressure	Max. 1.0 MPa / 145 PSI

The table below shows technical data for water and air quality:

Parameter	Value
Water quality	Normal filtered industrial water quality, 80 to 100 mesh.
Air quality	Use clean air. When there is excessive condensate, install a device that will eliminate water, such as a dryer or water separator (Drain Catch) on the inlet side of the air filter.

Continues on next page

2 Installation

2.10.1 Installation of Water and air unit

Continued

Required equipment



Equipment, etc	Art. no.	Note
Water and Air unit	For spare part number see chapter: <ul style="list-style-type: none"> Spare parts on page 217. 	
Standard toolkit, DressPack	3HAC17290-7	The contents are defined in section Toolkits, DressPack on page 213.

Reference documents

Document	Document number	Note
<i>Circuit diagram - DressPack for spot-welding SWC IRC5 M2004</i>	3HAC026208-001	Valid for all robots without PROFINET.
<i>Circuit diagram - DressPack SWC IRC5 Design 2014 PROFINET</i>	3HAC044736-001	Valid for all robots with option 782-13 Bosch MFDC PROFINET.

Installation of Water and air unit

The procedure below details how to install the Water and Air unit on the robot base.

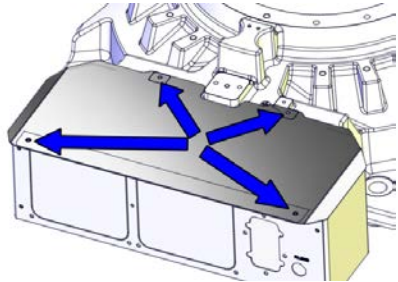
	Action	Note
1	 DANGER Turn off all: <ul style="list-style-type: none"> • electric power supply • water pressure supply • air pressure supply to the robot, before entering the robot working area.	
2	Remove the attachment screws securing the top cover at the base of the robot. Do not remove the top cover!  Note The screws will be reused when fitting brackets.	 xx1300002322

Continues on next page

2 Installation

2.10.1 Installation of Water and air unit *Continued*

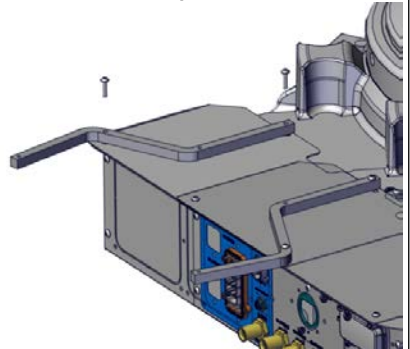
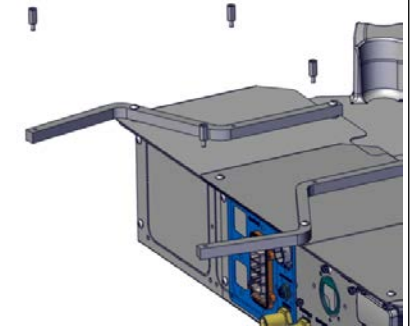
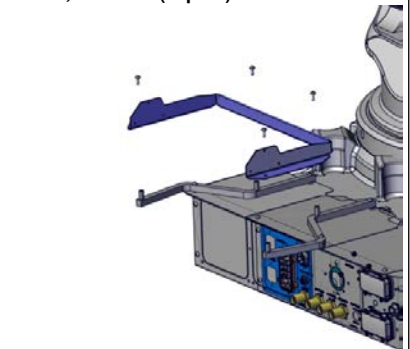
	Action	Note
3	Fasten the brackets.	Screw M6x25 (4 pcs)  xx1700000992
4	Attach distance screws to bracket.	Distance screw 3HAC14845-1, M6, (4 pcs)  xx1700000991
5	Fit the bracket on the distance screws with the top cover attachment screws.	Screw, M6x16 (4 pcs)  xx1700000990

Continues on next page

2 Installation

2.10.1 Installation of Water and air unit

Continued

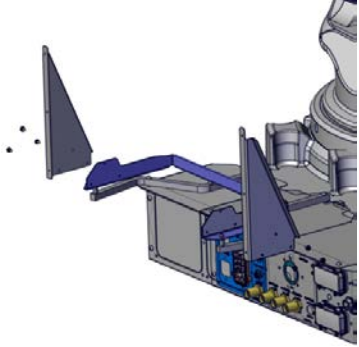
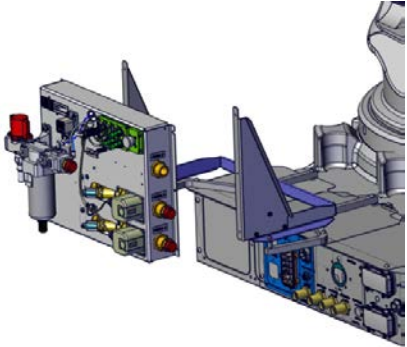
	Action	Note
6	Fit brackets right and left with their attachment screws.	Screw, 3HAC024936-001 (2x 3 pcs)  xx1700000989
7	Fit the water and air unit to the brackets with its attachment screws (Fastite).	 xx1700000988

Connections to Water and Air unit

The figure shows the connections at the robot base.

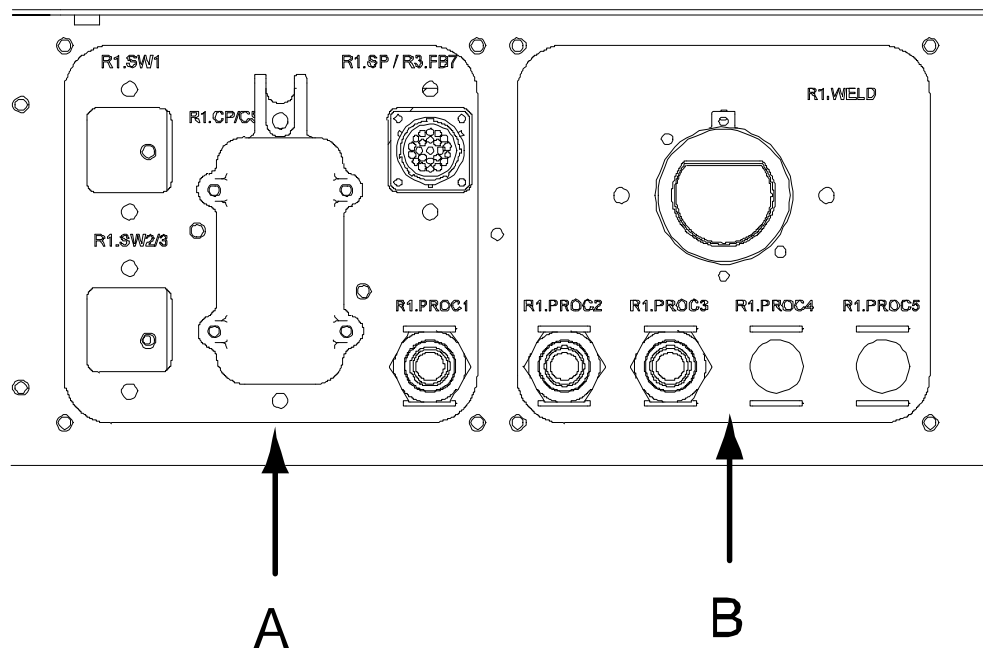

xx0600003178

Continues on next page

A	Customer plate
B	Process plate

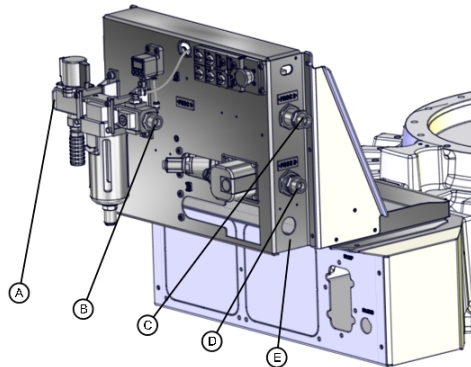

xx1300002326

Item in figure	Connect to:	Function:
A	Shop compressed air supply	
B	PROC1 on robot base	Compressed air supply to robot
C	PROC2 on robot base	Water in circuit
D	PROC3 on robot base	Water return circuit
E	PROC4 on robot base Note! Only the position of this connection is shown in the figure!	Depending on option selected: <ul style="list-style-type: none"> • Second water return • Regulated air



CAUTION

Do not tighten the brass couplings for water and air with excessive force.

Tightening torque:

- Brass coupling 1/2": 31 Nm.
- Stainless steel coupling 1/2": 49 Nm.
- Brass coupling 3/8": 17 Nm.
- Mixed metals: Use the lower tightening torque value of the two metals.

Always apply Molykote P1900 to stainless steel couplings and apply if needed for couplings of mixed metals or brass.

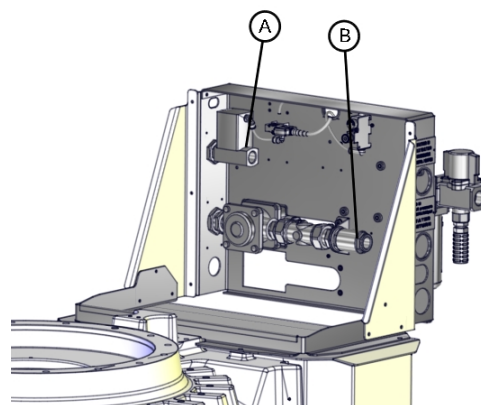

xx1300002327

Continues on next page

2 Installation

2.10.1 Installation of Water and air unit

Continued

Item in figure	Connect to:	Function:
A	Shop water supply	
B	Shop water drain Note! In case of a second water return, the water drain connection is moved to the outside of the mounting plate!	

Shop water supply

Use this procedure to connect the Water and Air unit to the shop water supply.

	Action	Note
1	Route the water supply hose through the upper hole in the mounting plate.	
2	Connect the hose to the fitting with a G $\frac{1}{2}$ " thread on the solenoid valve (A).  CAUTION Do not tighten the brass couplings for water and air with excessive force.	Tightening torque: <ul style="list-style-type: none"> • Brass coupling 1/2": 31 Nm. • Stainless steel coupling 1/2": 49 Nm. • Brass coupling 3/8": 17 Nm. • Mixed metals: Use the lower tightening torque value of the two metals. Always apply Molykote P1900 to stainless steel couplings and apply if needed for couplings of mixed metals or brass.

Shop compressed air supply

Use this procedure to connect the Water and Air unit to the shop compressed air supply.

	Action	Note
1	Connect the air hose to the fitting with a G $\frac{1}{2}$ " thread on the air shut off valve (C).  CAUTION Do not tighten the brass couplings for water and air with excessive force.	Tightening torque: <ul style="list-style-type: none"> • Brass coupling 1/2": 31 Nm. • Stainless steel coupling 1/2": 49 Nm. • Brass coupling 3/8": 17 Nm. • Mixed metals: Use the lower tightening torque value of the two metals. Always apply Molykote P1900 to stainless steel couplings and apply if needed for couplings of mixed metals or brass.

Water drain connection, One water return

Use this procedure to connect the water drain connection with one water return, to the Water and Air unit.

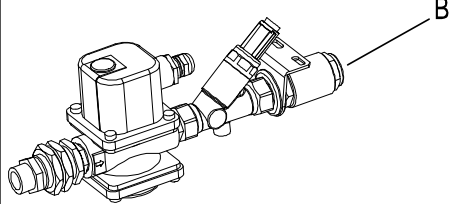

	Action	Note
1	Route the water drain hose through the lower hole in the mounting plate.	

Continues on next page

Action	Note
<p>2 Connect the hose to the fitting with a G$\frac{1}{2}$" thread on the check-valve.</p> <p> CAUTION</p> <p>Do not tighten the brass couplings for water and air with excessive force.</p>	 <p>xx0600003348</p> <ul style="list-style-type: none"> B: Water drain connection, one water return

Water drain connection, Two water return

Use this procedure to connect the water drain connection with two water return, to the Water and Air unit.

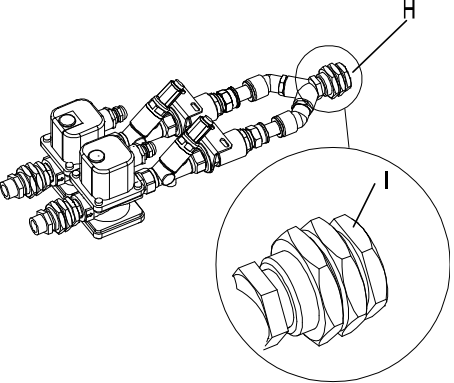
Action	Note
<p>1 Connect the hose to the <i>bulkhead fitting</i> with a G$\frac{1}{2}$" thread.</p> <p> CAUTION</p> <p>Do not tighten the brass couplings for water and air with excessive force.</p> <p> Note</p> <p>Any rotation of the bulkhead fitting must be avoided when mounting. Hold the <i>outer part of the bulkhead fitting</i> with a suitable tool, in order to prevent rotation.</p>	 <p>xx0600003349</p> <p>Parts:</p> <ul style="list-style-type: none"> H: Bulkhead fitting I: Outer part of bulkhead fitting

Hoses connecting Robot and Water and Air unit

Use this procedure to connect hoses between manipulator and Water and Air unit.

Action	Note
<p>1  CAUTION</p> <p>Do not tighten the brass couplings for water and air with excessive force.</p>	<p>Tightening torque:</p> <ul style="list-style-type: none"> Brass coupling 1/2": 31 Nm. Stainless steel coupling 1/2": 49 Nm. Brass coupling 3/8": 17 Nm. Mixed metals: Use the lower tightening torque value of the two metals. <p>Always apply Molykote P1900 to stainless steel couplings and apply if needed for couplings of mixed metals or brass.</p>
<p>2 Connect Proc 1 on the Water and Air unit with Proc 1 on the robot.</p>	
<p>3 Connect Proc 2 on the Water and Air unit with Proc 2 on the robot.</p>	

Continues on next page

2 Installation

2.10.1 Installation of Water and air unit

Continued

	Action	Note
4	Connect Proc 3 on the Water and Air unit with Proc 3 on the robot.	
5	Connect Proc 4 on the Water and Air unit with Proc 4 on the robot.	If second water return or regulated air is used.
6	Secure all connectors.	See <i>Tightening torques</i> in section Screw joints on page 209 .

2.10.2 Return water flow control

Overview

The mechanical flow control valve is pre-set at delivery at 8 liter/min (maximum flow).

Settings

The procedure below details how to set the mechanical flow control valve.

	Action	Note
1	Open the solenoid valve on the water inlet.	
2	Water flow is indicated on the scale of the Flow control valve.	
3	Adjust water flow by using the red adjusting knob on the scale of the Flow control valve to the required set flow.	The red adjusting knob is placed on the back of the Water and Air unit.

2 Installation

2.10.3 Return water flow switch setting

2.10.3 Return water flow switch setting



Introduction

The mechanical flow switch is pre-set at delivery to 8 liters/min at 0.2 MPa water pressure.

If the water pressure exceeds 0.2 MPa, the setting cannot be done with the graduation on the window name plate, as the pressure affects the measured flow. Please perform the setting as described in the following procedure.

Settings

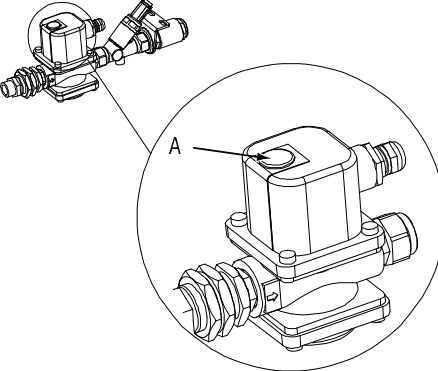
The procedure below details how to set the mechanical flow switch.

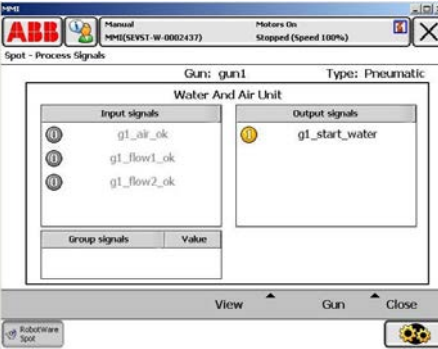
	Action	Note
1	Open the solenoid valve on the water inlet.	
2	Water flow is indicated on the scale of the flow control valve.	
3	Adjust the water flow to the level where the Flow switch shall give alarm. Use the red adjusting knob on the scale of the flow control valve.	See section Return water flow control on page 109 .
4	<p>To adjust the set flow on the mechanical Flow switch, remove the grommet on the upper cover and rotate the flow adjusting gear by using a flat screwdriver.</p> <p>Turning clockwise will increase the set flow and turning counterclockwise will decrease the set flow.</p>	 <p>xx0600003346</p> <p>Parts:</p> <ul style="list-style-type: none"> A: Flow switch
5	<p>Depending on initial value, increase or decrease the set value until the <code>g_flow_ok</code> changes, by observing the <i>Process Signals window</i> on the FlexPendant.</p> <p> Note</p> <p>The indicated flow level may differ from real flow as the flow switch is affected by the water pressure.</p>	 <p>xx0600003355</p> <ul style="list-style-type: none"> Process Signals window
6	Refit the grommet on the flow switch.	

Continues on next page

	Action	Note
7	Increase water flow to desired level by adjusting the flow control valve. Put back the red adjusting knob on the back of the Water and Air unit.	 Note This level shall be higher than the alarm level.

2 Installation

2.10.4 Setting of air pressure switch (only applicable to type S)

2.10.4 Setting of air pressure switch (only applicable to type S)

General

The digital pressure switch monitors the shop floor air pressure.

Settings

The procedure below details how to set the digital pressure switch. The example shows how to set according to the pre-set values. The sensor will set **g1_air_ok** in the robot controller when pressure reaches 0.5 MPa and reset **g1_air_ok** if pressure goes lower than 0.45 MPa.

	Mode	Action	Note
1	Preparation	Make sure that the pressure switch is connected to 12-24 VDC power.	
2	Initialize	In measurement mode, press SET button for two seconds or more.	0
3	Selection of Unit	Press UP or DOWN button until the display matches the figure on the right, then press the SET button.	PA PA indicates MPa.
4	OUT1 Output type Setting	Press UP or DOWN button until display matches the figure on the right, then press the SET button.	1no ("1no" = Output 1 normally open)
5	OUT2 Output type Setting	Ignore and press the SET button.	2n*
6	Response Time Setting	Press UP or DOWN button until display matches the value on the right, then press the SET button.	24
7	Auto/Manual Setting	Press UP or DOWN button until display matches the value on the right, then press the SET button.	ñAn (ñAn indicates manual setting)
8	Value Setting	In measurement mode, press the SET button.	
9	Set Point Value for OUT1(1) Pressure OK goes high	When the display blinks, press UP or DOWN button without pressing the SET button. Press UP or DOWN button until the display matches the value on the right, then press the SET button.	P_1 0.500
10	Set Point Value for OUT1(2) Pressure OK goes low	When the display blinks, press UP or DOWN button without pressing the SET button. Press UP or DOWN button until the display matches the value on the right, then press the SET button.	P_2 0.450
11	Set Point Value for OUT2(1)	Ignore and press the SET button.	P/n3
12	Set Point Value for OUT2(2)	Ignore and press the SET button.	P/n4
13		The pressure switch changes to measurement mode. All settings are completed.	0
14	Zero Clear Function	Press UP and DOWN buttons simultaneously for about 2 seconds, under atmospheric pressure.	0

Continues on next page

2.10.4 Setting of air pressure switch (only applicable to type S)

Continued

Pre-set values

Parameter	Pre-set value
Unit specification	MPa
Hysteresis mode	Normally open
Response time	24 ms
High pressure P_1	0.5 MPa
Low pressure P_2	0.05 MPa

2 Installation

2.10.5 Setting of electrical proportional valve (option)

2.10.5 Setting of electrical proportional valve (option)

Introduction

The electrical proportional valve is available as an option.

The output pressure from the proportional valve is set by a voltage input signal, 0 - 10 VDC.

The output pressure range is 0.005 - 0.9 MPa.

I/O configuration

The following has to be done in order to configure the system to automatically feed the electrical proportional valve with 24 V only, when there is a sufficient air pressure indicated by the air pressure switch. If there is not enough pressure, the electrical proportional valve works continuously and the lifetime may be shortened.

The related input and output is **gx_air_ok** and **gx_epvalve_on**, where x represents the actual gun. The example below shows the setting for gun 1.

	Action	Note
1	Create a digital output signal named g1_epvalve_on on unit SWBOARD1 and unit mapping 14 .	
2	Create a cross connection between g1_air_ok and g1_epvalve_on .	

Setting

Normally the pre-set values are used. But if other settings are desired, do as described below.

The procedure below details how to set the proportional valve.

Mode		Action	Note
Preparation	1	Make sure that the 12-24 VDC power is connected.	
Release key locking	2	The indication <i>Loc</i> flashes on LED by pushing the DOWN key for two seconds or more. The key locking function is released by pushing the SET key here.	The keys are locked after the power is turned on and cannot be operated. <i>Loc</i> is indicated on LED when the keys are pushed.
Min. pressure setting	3	Press the SET key.	<i>F_1</i> is indicated on LED.
	4	Set the required min. pressure by using the UP and DOWN keys.	The min. pressure is equal to 0 VDC input signal.
	5	When finished, press the SET key.	<i>F_2</i> is indicated on LED.
Max. pressure setting	6	Set the required max. pressure by using the UP and DOWN keys.	The max. pressure is equal to 10 VDC input signal.
	7	When finished press the SET key.	<i>P_1</i> is indicated on LED.

Continues on next page

Mode		Action	Note
Setting switch output, P1	8	Set the value 0 (zero) by using the UP and DOWN keys.	There are three kinds of modes of the switch function: <ul style="list-style-type: none"> • Window Comparator Mode • Hysteresis Mode • Out of range Mode The choice of the different modes is determined by setting the two values P1 and P2 and the relation between value P1 and value P2. P1=P2=0 Out of range mode
	9	When finished, press the SET key.	P_2 is indicated on LED.
Setting switch output, P2	10	Set the value 0 (zero) by using the UP and DOWN keys.	
	11	When finished, press the SET key.	LED returns to the present pressure indication. Setting is completed.
Active key locking	12	The indication <i>unL</i> flashes on LED when the DOWN key is pressed for two seconds or more. Key locking function is released by pressing SET key here.	

Pre-set values

Parameter	Pre-set value
Min. pressure F1	0.0 MPa
Max. pressure F2	0.9 MPa
Switch output	Out of range mode (P1=P2=0)

Insufficient air pressure (Only applicable to type S)

If the Air pressure switch indicates too low pressure, the 24 V supply of the Electrical proportional valve is disconnected and the valve stops from operating.

If the Air pressure switch is to be set without having sufficient air pressure, the corresponding digital output *gx_epvalve_on* supplying the valve with 24 V, has to be set manually. This is most easily done by simulating input *gx_air_ok*.

2 Installation

2.11 Test run after installation, maintenance, or repair

2.11 Test run after installation, maintenance, or repair

Safe handling

Use the following procedure after installation, maintenance, or repair, before initiating motion.



DANGER

Initiating motion without fulfilling the following aspects, may increase the risk for injury or cause damage to the robot.

	Action
1	Remove all tools and foreign objects from the robot and its working area.
2	Verify that the robot is properly secured to its position by all screws, before it is powered up.
3	Verify that any safety equipment installed to secure the position or restrict the robot motion during service activity is removed.
4	Verify that the fixture and work piece are well secured, if applicable.
5	Verify that all safety equipment is installed, as designed for the application.
6	Verify that no personnel are inside the safeguarded space.
7	If maintenance or repair has been done, verify the function of the part that was maintained.
8	Verify the application in the operating mode manual reduced speed.

Collision risks



CAUTION

When programming the movements of the robot, always identify potential collision risks before initiating motion.

3 Maintenance

3.1 Introduction

Structure of this chapter

This chapter describes all the maintenance activities recommended for the DressPack IRB 8700.

It is based on the maintenance schedule found at the beginning of the chapter. The schedule contains information about required maintenance activities including intervals, and refers to procedures for the activities.

Each procedure contains all the information required to perform the activity, including required tools and materials.

The procedures are gathered in different sections and divided according to the maintenance activity.

Safety information

Observe all safety information before conducting any maintenance work.

There are general safety aspects that must be read through, as well as more specific safety information that describes the danger and safety risks when performing the procedures. Read the chapter [Safety on page 15](#) before performing any maintenance work.

The maintenance must be done by qualified personnel in accordance with the safety requirements set forth in the applicable national and regional standards and regulations.

3 Maintenance

3.2.1 Maintenance schedule

3.2 Maintenance schedule and component life

3.2.1 Maintenance schedule

General

The DressPack must be maintained regularly to ensure its function. The lifetime of a process cable package can be extended with the correct preventive maintenance activities. A daily visual check of the DressPack is highly recommended, which is normally performed by robot production personnel. It is essential that the person performing the visual check have basic training in ABB DressPack.

Wear parts

Wear parts should be replaced before considerable damage occurs to the process cable package. Replace wear parts before the part is completely damaged.

The following parts are considered as wear parts:

- Protection sleeves
- Protective hose
- Hose reinforcement

Activities and intervals, standard equipment

The sections referred to in the table can be found in the different chapters for each maintenance activity.

The table below specifies the required maintenance activities and intervals:

Maintenance activity	Equipment	Interval	Detailed in section:
Inspection	All cables	Regularly ⁱ	Preventive inspection of all cables, DressPack on page 120
Inspection	DressPack upper arm	Regularly <i>i</i>	Preventive inspection, DressPack on page 122
Cleaning	DressPack upper arm	Regularly <i>i</i>	Cleaning, DressPack upper arm on page 128

ⁱ "Regularly" implies that the activity is to be performed regularly, but the actual interval may not be specified by the robot manufacturer. The interval depends on the operation cycle of the robot, its working environment and movement pattern.

Generally, the more contaminated the environment, the closer the maintenance intervals. Also, the more demanding the movement pattern (sharper bending cable harness), the closer the intervals.

DressPack upper arm cable package

Based on experience, some parts are more exposed to wear. Therefore the DressPack upper arm cable package should be inspected according to the following schedule.

Interval	Action
Weekly	None
Every two weeks	Inspection wear
Every third month	Inspection

Continues on next page

Interval	Action
After changing movement pattern	Inspection

3 Maintenance

3.3.1 Preventive inspection of all cables, DressPack

3.3 Inspection activities DressPack

3.3.1 Preventive inspection of all cables, DressPack

Cables in the DressPack system

There are many different cables used in the DressPack system. The different cables used are listed in Spare parts section.

The inspection activities described below are a general description, and does not refer to any specific cable.

Required equipment

Equipment	Art. no.	Note
Standard toolkit	3HAC17290-7	The contents are defined in section Toolkits, DressPack on page 213 .

Inspection

The procedure below details how to inspect all cables included in the DressPack system.

This instruction applies to:

- DressPack upper arm and cables and hoses contained within
- DressPack lower arm and cables and hoses contained within
- DressPack floor and cables and hoses contained within.

	Action	Note
1	 DANGER Turn off all: <ul style="list-style-type: none">• electric power supply• hydraulic pressure supply• air pressure supply to the robot, before entering the safe-guarded space.	
2	Make sure that the unit is clean and not overly contaminated.	Clean if required as detailed in section Cleaning, DressPack upper arm on page 128 .
3	Make sure that all bolts are fastened.	Recommended tightening torques are specified in section Screw joints on page 209 .
4	Make sure that all connections are fastened.	Re-tighten if necessary.
5	Check for mechanical wear, especially in areas where the cable/hose package rub against, or move close to, the robot or any other structure. Especially check any cable/hose package at the robot wrist.	Replace any worn items as detailed in the chapter Repair on page 135 . Re-adjust the assembly after installation.
6	If any of the protective sleeves are worn, rotate it or replace it.	

Continues on next page

3.3.1 Preventive inspection of all cables, DressPack *Continued*

	Action	Note
7	Check the attachments of the cable/hose package, to make sure they are properly secured.	
8	Check all cable retainers, to make sure the cables/hoses are securely locked in the cable retainers.	

3 Maintenance

3.3.2 Preventive inspection, DressPack

3.3.2 Preventive inspection, DressPack

Location of DressPack upper arm

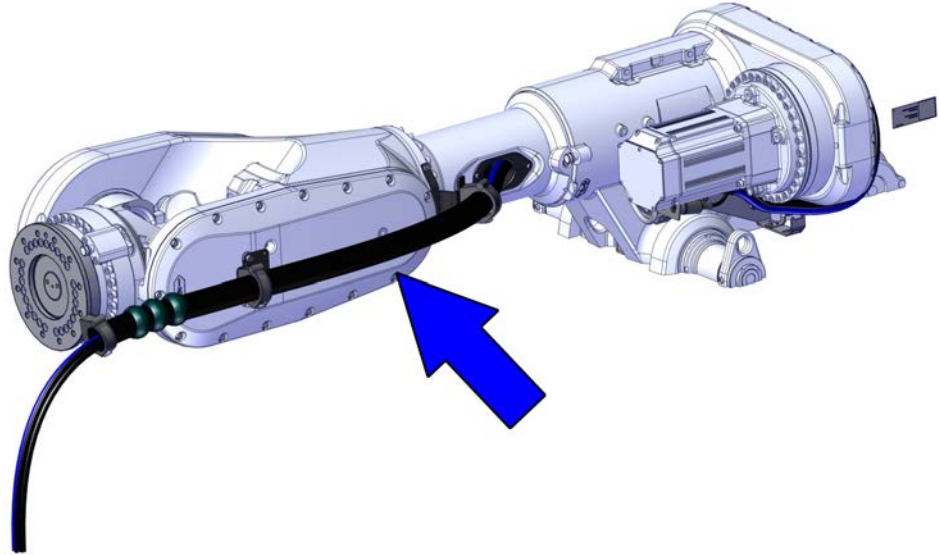

xx1500003018

The figure shows the cable package IRBDP MH3 UI.

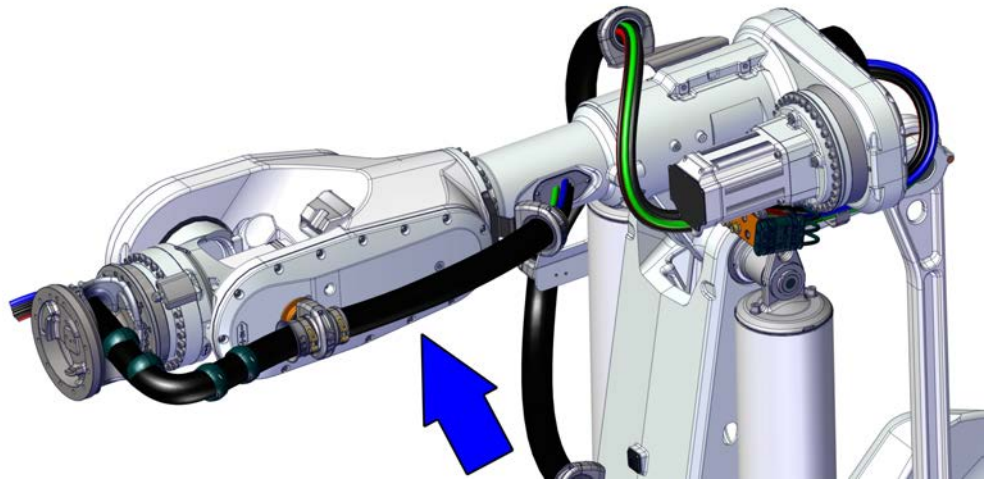

xx1500002777

The figure shows the cable package IRBDP MH6/SW6 UI.

Required equipment

Equipment	Article number	Note
Standard toolkit	3HAC17290-7	The contents are defined in section Toolkits, DressPack on page 213 .

Continues on next page

Inspection - Robot standing still

Use this procedure to inspect the DressPack when the robot is not in motion.

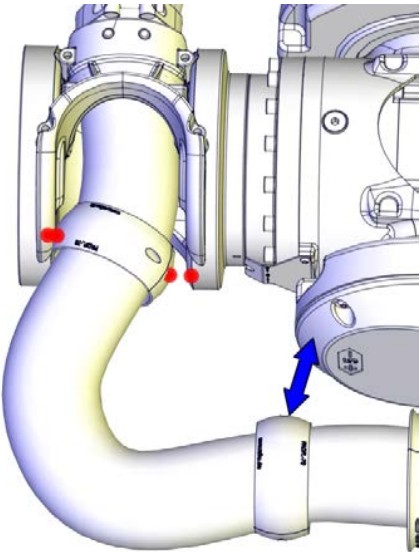
	Action	Note
1	 DANGER Turn off all: <ul style="list-style-type: none"> • electric power supply • hydraulic pressure supply • air pressure supply to the robot, before entering the safe-guarded space.	
2	Make sure that the DressPack is not contaminated.	If required, clean as detailed in section Cleaning, DressPack upper arm on page 128 .
3	Make sure that all bolts are fastened.	Recommended standard tightening torques are specified in section Screw joints on page 209 .
4	<p>Only applicable to cable packages IRBDP SW6 UI & IRBDP MH6 UI:</p> <p>Check the position and state of the <i>protective sleeves</i>.</p> <p>Correct fitting of the protective sleeve at the wrist cover:</p> <ul style="list-style-type: none"> • align the center of the radius on the front end of the wrist cover, with the center of the radius on the corresponding protective sleeve. See figure! <p>Correct fitting of the protective sleeve at the axis-6 cable support:</p> <ul style="list-style-type: none"> • align the center of the radius (right side) of the axis-6 cable support, with the center of the radius of the corresponding protective sleeve. See figure! <p>Replace protective sleeves if needed. For correct fitting of the new protective sleeve, see instructions above for a correct fitting. The number of protective sleeves must remain the same (2 pcs).</p>	 <p>xx140000224</p>
5	Make sure all cable straps are tight enough to prevent the cable package from moving in an undesired way.	
6	Make sure that the velcro strap are not too tight. The cables should be able to twist.	
7	Make sure that the cable package is properly connected at: <ul style="list-style-type: none"> • the connection plate • the robot base • the lower arm • the tool on the turning disc of the robot. 	
8	Make sure that all connections are fastened and that there are no leaks.	Re-tighten if necessary.

Continues on next page

3 Maintenance

3.3.2 Preventive inspection, DressPack

Continued

	Action	Note
9	Make sure that the cable package is not cracked or damaged in any other way.	
10	Check all cable clamps securing the process cable package and protective hose for tightness.	Tightening torques are specified either in: <ul style="list-style-type: none">• Installation chapter (non-standard tightening torques) or• standard tightening torque table (standard tightening torques).

Inspection - Reduced speed

The following procedure details how to inspect the DressPack upper arm when the robot is moving in reduced speed.



WARNING

A robot in motion is dangerous and may cause severe personal injuries, if safety procedures are not followed. Hence, all work must be performed outside the robots working range and outside the robots safety area.

Secure the following before work starts:

- Check that all emergency stops are fully functional.
- Close and activate all safety equipment (safety gates and/or safety curtains etc.).

	Action
1	Make sure that no hoses or cables, or parts thereof, touch any part of the robot structure in a way that may cause wear.
2	Make sure all cables and hoses move smoothly together during operation and that no part of the cable package moves in a different pattern.

Inspection - Full speed

The following procedure details how to inspect the DressPack upper arm, when the robot is moving in full speed.



WARNING

A robot in motion is dangerous and may cause severe personal injuries, if safety procedures are not followed. Hence, all work must be performed outside the robots working range and outside the robots safety area.

Secure the following before work starts:

- Check that all emergency stops are fully functional.
- Close and activate all safety equipment (safety gates and/or safety curtains etc.).

	Action	Note
1	Make sure that no hoses or cables, or parts thereof, touch any part of the robot structure (or something in the vicinity of it) in a way that may cause wear.	

Continues on next page

	Action	Note
2	Make sure all cables and hoses move smoothly together during operation and that no part of the cable package moves in a different pattern.	

3 Maintenance

3.3.3 Preventive inspection of Water and air unit

3.3.3 Preventive inspection of Water and air unit

Location of Water and air unit

The Water and air unit is located as shown in the figure.

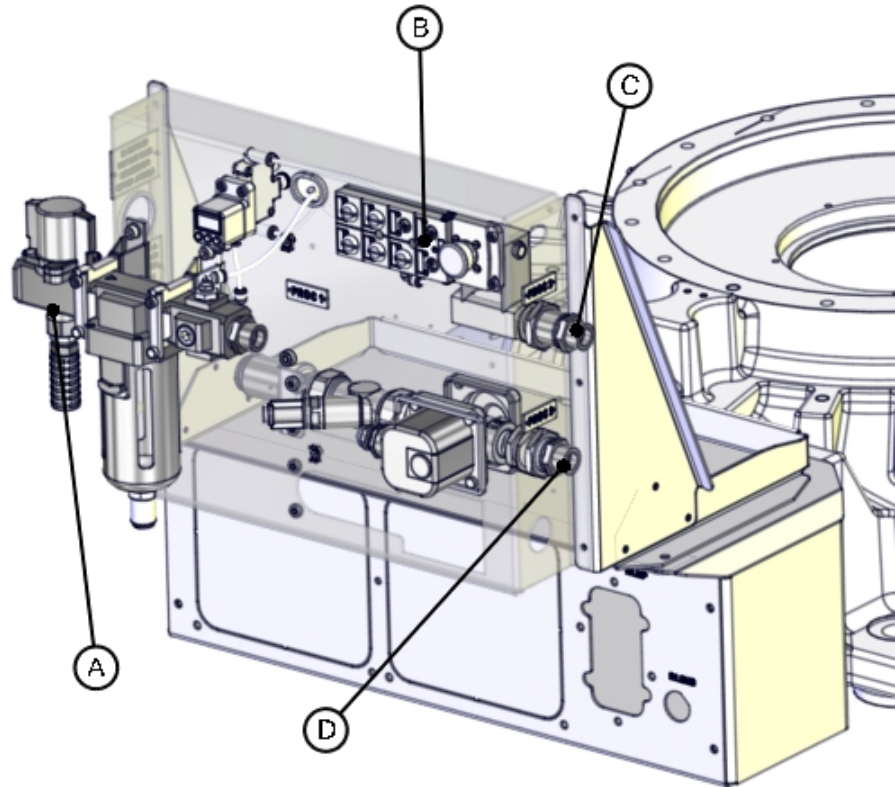

xx1300002328

A	Air supply circuit
B	Split box
C	Water in circuit
D	Water return circuit

Required equipment

Equipment	Article number	Note
Standard Toolkit, DressPack	3HAC17290-7	The contents are defined in section Toolkits, DressPack on page 213 .

General inspection

The procedure below describes how to perform a general inspection of the Water and air unit.

	Action	Note
1	Check that the Water and air unit is not contaminated.	Clean if required as detailed in section Cleaning, Water and air unit on page 129 .

Continues on next page

	Action	Note
2	Check that the bolts are fastened.	Recommended tightening torques are specified in section Tightening torque on page 210 .
3	<p>Check that all connections are correctly made and that there are no leaks.</p> <p> CAUTION</p> <p>Do not tighten the brass couplings for water and air with excessive force.</p>	<p>Retighten if necessary.</p> <p>Tightening torque:</p> <ul style="list-style-type: none"> • Brass coupling 1/2": 31 Nm. • Stainless steel coupling 1/2": 49 Nm. • Brass coupling 3/8": 17 Nm. • Mixed metals: Use the lower tightening torque value of the two metals. <p>Always apply Molykote P1900 to stainless steel couplings and apply if needed for couplings of mixed metals or brass.</p>

Inspection, air supply circuit

The procedure below describes how to inspect the air supply circuit.

	Action	Note
1	<p>Check if there is water in the filter receptacle.</p> <p>Normally the filter receptacle is drained automatically in case of a fall of air pressure. If there is no fall of pressure in the air system, there is an automatic draining of the system, when the water level reaches a certain level.</p>	<p>If there is a lot of water in the filter receptacle, this is a sign that the supplied air consist of too much water.</p> <p>If this is the case, steps must be taken to correct this problem!</p>
2	Drain the air filter receptacle manually by pressing a small pin at the bottom of the air filter unit.	
3	Make a check that there is no leakage.	Retighten if necessary!
4	Make a check of the condition of the air filter.	<p>If needed replace the air filter.</p> <p>Normally the filter should be replaced after one year of use.</p>

Inspection, water in and water return circuits

The procedure below describes how to inspect the water in and water return circuits.

	Action	Note
1	Open the hand operated ball valve for water inlet.	
2	Open the water return valve on the water in circuit.	
3	Close the hand operated ball valve for water outlet.	
4	While the system is under pressure, check if there are any leaks.	Retighten if necessary!
5	Reset the system.	

3 Maintenance

3.4.1 Cleaning, DressPack upper arm

3.4 Cleaning activities

3.4.1 Cleaning, DressPack upper arm

Required equipment

Equipment	Art. no.	Note
Standard toolkit	3HAC17290-7	The contents are defined in section Toolkits, DressPack on page 213 .
Dry rag and medium soft brush		For cleaning the protective hose ribs.

Cleaning

The procedure below details how to clean the DressPack upper arm.

	Action	Note
1	Clean the DressPack upper arm exterior, in order to avoid filling up the spaces between the ribs with debris. Make sure to clean any areas where any hoses bend or rub against the robot. If the harness is not cleaned sufficiently, breakage of the protective hose may result.	Only use equipment and cleaning agents as specified in section Required equipment on page 120 .
2	Clean the slide sleeves of any sort of contamination.	

3.4.2 Cleaning, Water and air unit

Location of Water and air unit

The Water and air unit is located as shown in the figure.

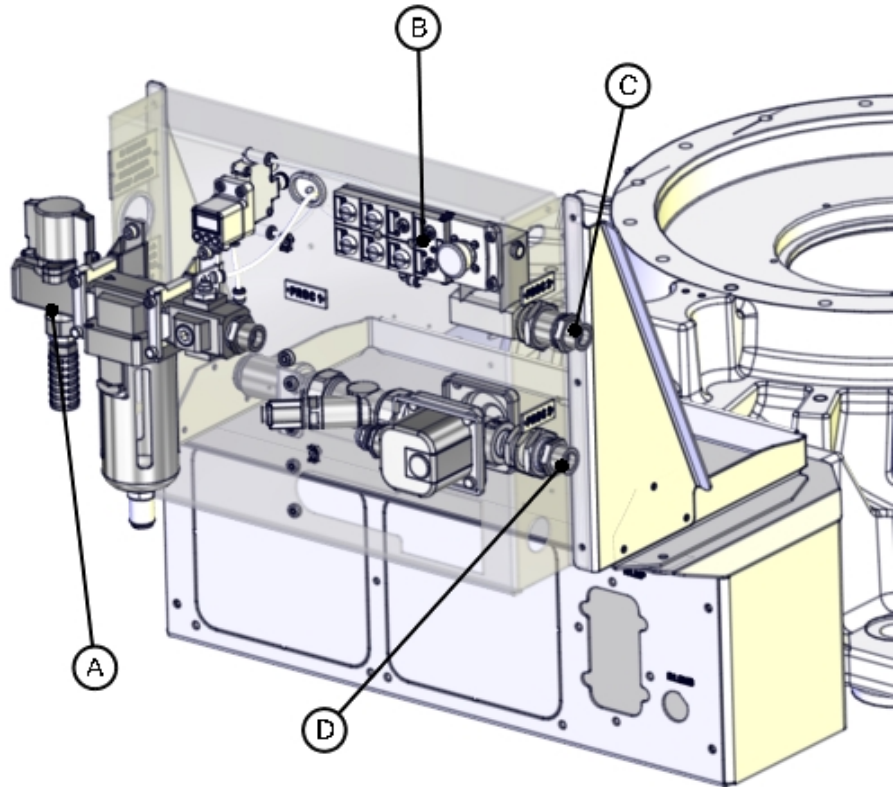

xx1300002328

A	Air supply circuit
B	Split box
C	Water in circuit
D	Water return circuit

Required equipment

Equipment	Note
Dry rag	When cleaning the Water and air unit, only use household neutral detergent.

Maintenance of Air filter

	Action	Note
1	Periodically inspect the resin bowl for cracks or other deterioration.	If found, replace the bowl with a new one.

Continues on next page

3 Maintenance

3.4.2 Cleaning, Water and air unit

Continued

	Action	Note
2	Periodically inspect the cleanliness of the resin bowl.	If the resin bowl is dirty, replace it with a new one or clean it. Use a household (neutral) detergent when cleaning, other detergent may break the bowl.
3	Replace the filter element within two years since first use.	Replacement of the air filter is detailed in section Replacement of Air filter element on page 202 .
4	Replace the filter after pressure drop from initial outlet reaches 0.1 MPa.	Replacement of the air filter is detailed in section Replacement of Air filter element on page 202 .
5	Replace if the filter element is broken.	Replacement of the air filter is detailed in section Replacement of Air filter element on page 202 .

3.4.3 Cleaning the Fan unit

Overview

Use this section to clean the fan unit.

Location

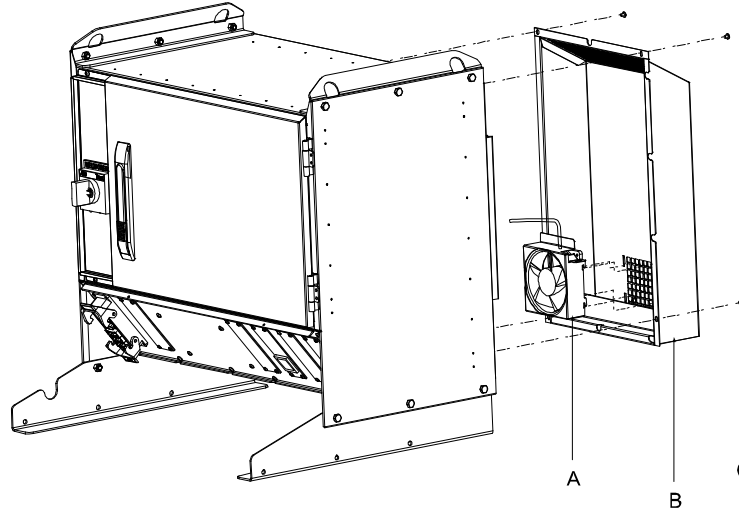

en0500001924

A	Fan holder with fan
B	Fan casing
C	Attachment screws M5x9, Fastite screw (4 pcs)

Required equipment

Equipment	Article number	Note
Standard toolkit DressPack	3HAC17290-7	The contents are defined in section Toolkits, DressPack on page 213 .
Vacuum cleaner	-	

Maintenance procedure

	Action	Note
1	 DANGER Before any work inside the cabinet, please observe the safety information in the section <i>DANGER - Make sure that the main power has been switched off</i> in the product manual for the IRC5 controller.	
2	Remove the attachment screws holding the fan casing.	Shown in the section Location on page 131 Screw M5x9 Fastite (4 pcs)
3	Disconnect the fan connector.	

Continues on next page

3 Maintenance

3.4.3 Cleaning the Fan unit

Continued

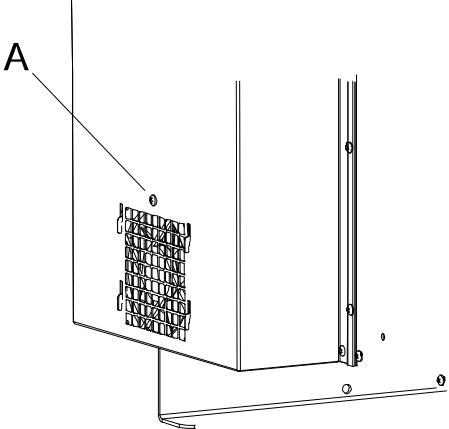
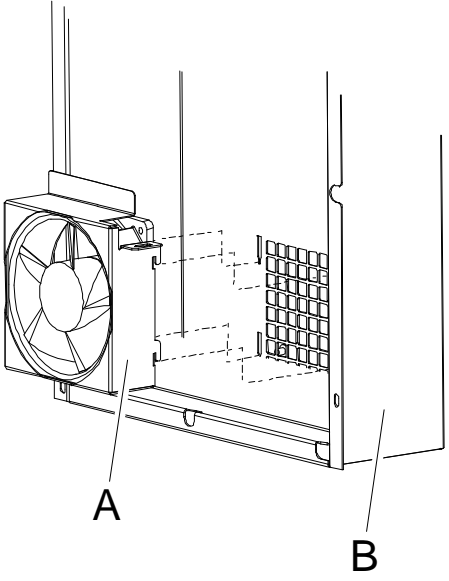
	Action	Note
4	Remove the stop screw.	 <p>xx0500002232</p> <ul style="list-style-type: none">• A: Stop screw
5	Lift out the fan holder with fan.	 <p>xx0500002234</p> <ul style="list-style-type: none">• A: Fan holder with fan• B: Fan casing
6	Clean the fan.	
7	Refit according to the steps above, in reverse order.	

3.4.4 Cleaning the Weld timer cooling fins

Overview

Use this procedure to clean the weld timer cooling fins.

Location

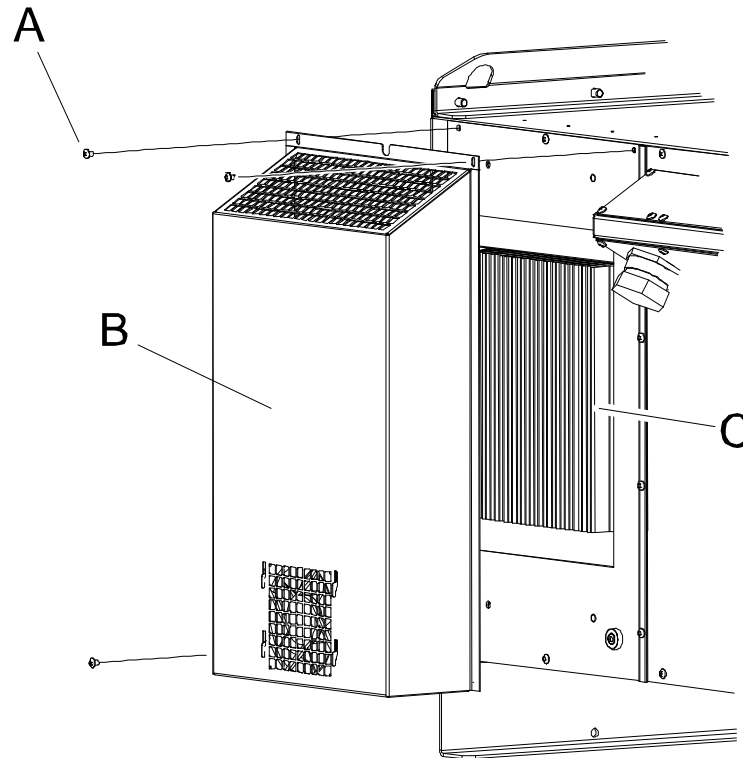

xx0500002240

A	Attachment screws M5x9 Fastite screw (3 pcs)
B	Fan casing
C	Cooling fins

Required equipment

Equipment	Art.no.	Note
Standard toolkit DressPack	3HAC17290-7	The contents are defined in section Toolkits, DressPack on page 213 .
Vacuum cleaner		

Continues on next page

3 Maintenance

3.4.4 Cleaning the Weld timer cooling fins

Continued

Maintenance procedure

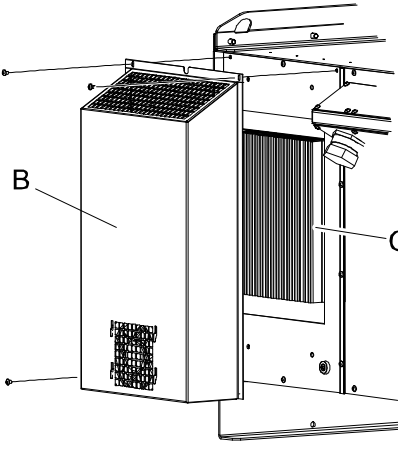
	Action	Note
1	 DANGER Before any work inside the cabinet, please observe the safety information in the section <i>DANGER - Make sure that the main power has been switched off</i> in the product manual for the IRC5 controller.	
2	Remove the attachment screws.	 <p>xx0500002240</p> <ul style="list-style-type: none"> • A: Attachment screw M5x9 Fastite (3 pcs) • B: Fan casing • C: Cooling fins
3	Disconnect the fan connector.	
4	Remove the fan casing.	
5	Clean the cooling fins with a vacuum cleaner.	
6	Refit the fan connector and fan casing.	

4 Repair

4.1 Introduction

Structure of this chapter

This chapter describes repair activities for the DressPack IRB 8700. Each procedure contains the information required to perform the activity, for example spare parts numbers, required special tools, and materials.

**WARNING**

Repair activities not described in this chapter must only be carried out by ABB.

Report replaced units

**Note**

When replacing a part on the DressPack IRB 8700, report to your local ABB the serial number, the article number, and the revision of both the replaced unit and the replacement unit.

This is particularly important for safety equipment to maintain the safety integrity of the installation.

Safety information

Make sure to read through the chapter [Safety on page 15](#) before commencing any service work.

4 Repair

4.2.1 Addition of functional ground (Paramulti)

4.2 DressPack cable package

4.2.1 Addition of functional ground (Paramulti)

Configuration of customer connection plates

Only for Paramulti DressPack and for spare part replacement.

The Paramulti DressPack spare part includes functional ground. If the installed DressPack has not included functional ground previously, following action needs to be done:

Drill an 8.4 mm hole in the customer plate according to the figure.

Customer connection plate at the base

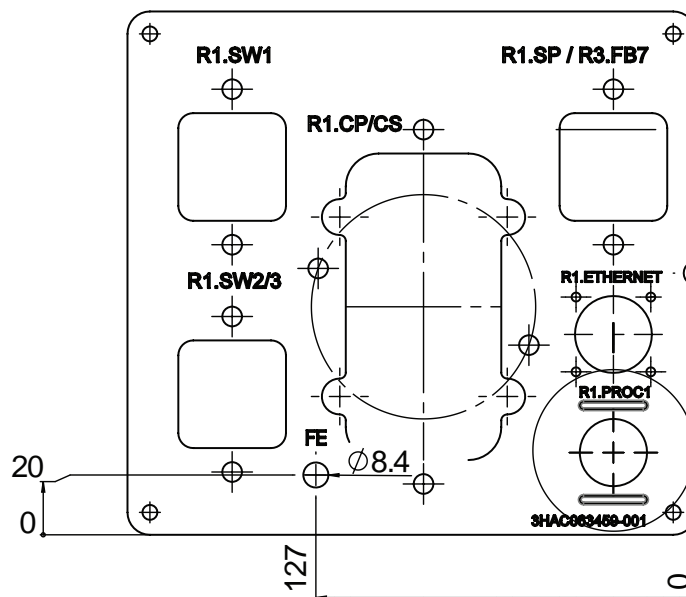

xx1900001268

4.2.2 Replacing the cable package IRBDP MH3 UI

Location of the cable package

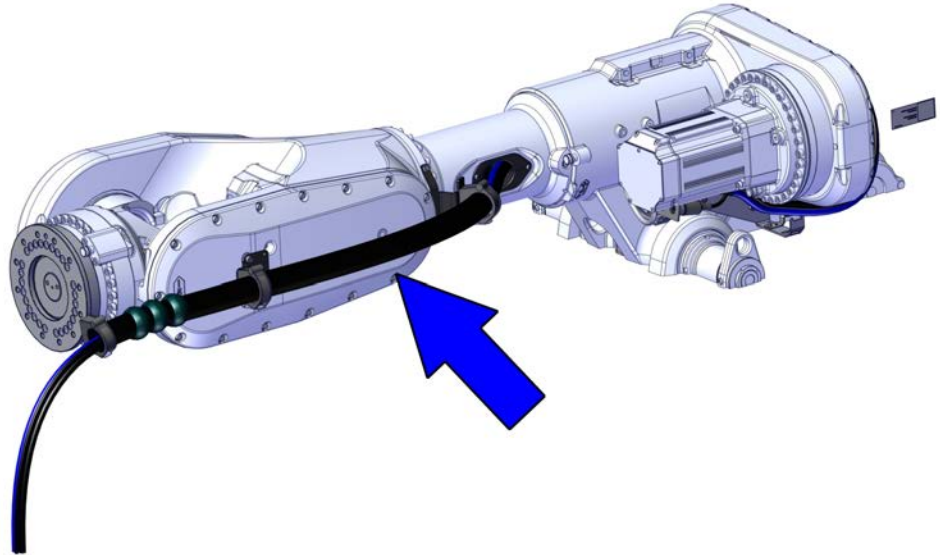

xx1500003018

Spare parts

Spare part	Spare part number	Note
Cable package IRBDP MH3 UI	Also see	

Required tools and equipment

Equipment, etc.	Article number	Note
Standard toolkit	-	Content is defined in section Standard toolkit on page 213 .

Removing the cable package IRBDP MH3 UI

Use this procedure to remove the cable package.

	Action	Note
1	 DANGER Turn off all: <ul style="list-style-type: none"> • electric power supply • hydraulic pressure supply • air pressure supply to the robot, before entering the safe-guarded space.	

Continues on next page

4 Repair

4.2.2 Replacing the cable package IRBDP MH3 UI

Continued

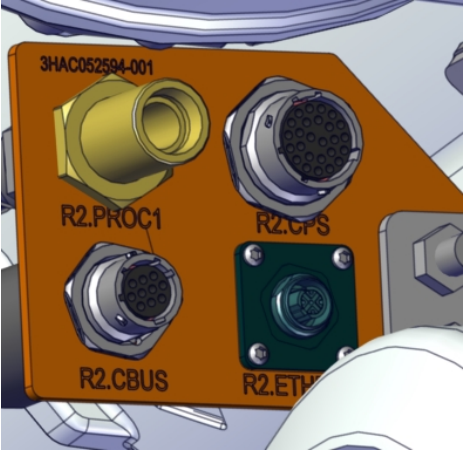
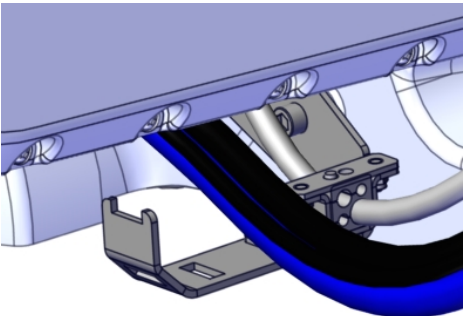
	Action	Note
2	<p> CAUTION</p> <p>The cable package is sensitive to mechanical damage. Handle it with care in order to avoid damaging the cabling or the connectors.</p>	
3	Disconnect the hose and cable connectors on the connection plate.	 <p>xx1500003038</p>
4	Open the velcro strap on the mounting plate.	 <p>xx1500003039</p>

Continues on next page

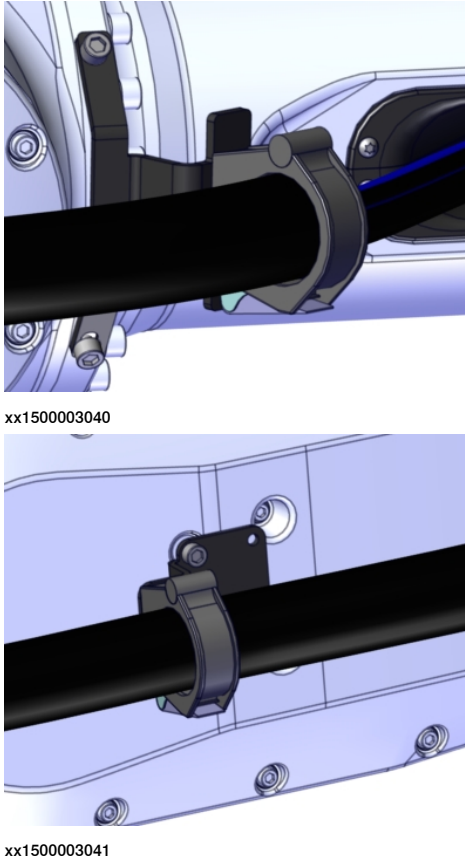
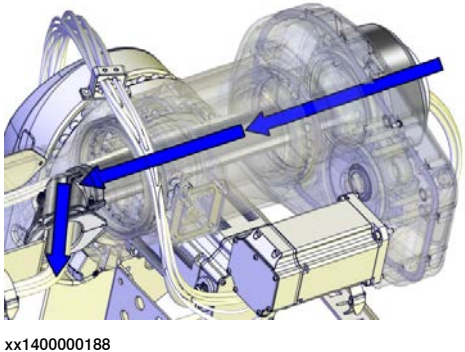
	Action	Note
5	Open the gripping clamps holding the cable package on the upper arm.	 <p>xx1500003040</p> <p>xx1500003041</p>
6	Carefully pull the cable package out of the tube and insert.	 <p>xx140000188</p>



Note

There are cable grease on the cables.

Refitting the cable package

Use this procedure to refit the cable package IRBDP MH3 UI.

Route the cable package





	Action	Note
1	Move the robot to a comfortable working position.	

Continues on next page

4 Repair

4.2.2 Replacing the cable package IRBDP MH3 UI

Continued

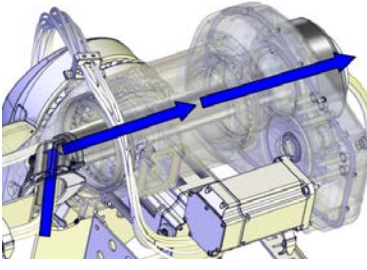

	Action	Note
2	 DANGER Turn off all: <ul style="list-style-type: none"> • electric power supply • hydraulic pressure supply • air pressure supply to the robot, before entering the safeguarded space.	
3	 CAUTION The cable package is sensitive to mechanical damage. Handle it with care in order to avoid damaging the cabling or the connectors.	
4	 Tip This procedure is best done by two persons working together - one pushing cabling and hoses into the tube and the other pulling them out at the wrist.	
5	Carefully push the cable package into the insert, through the tube and out in the back of the arm housing.  Tip The following order is preferable: <ol style="list-style-type: none"> 1 Cables 2 Hoses 3 Weld cables (where applicable) If there is a problem, remove the nut inside the tube.	 <small>xx140000095</small>

Apply cable grease

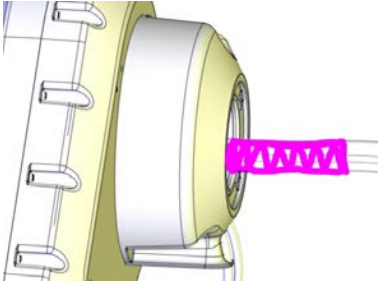
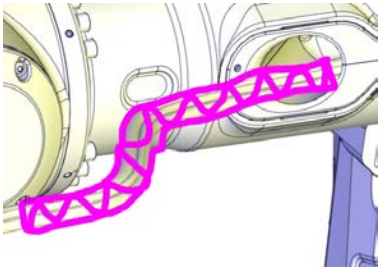

It is necessary to apply cable grease on the cable package inside the tube.

	Action	Note
1	Carefully pull the cable package out 10 to 15 centimeters longer than the final assembly position.	

Continues on next page

	Action	Note
2	Apply grease on the highlighted area.	 xx1400001389
3	Carefully push the cable package back into the tube and out through the insert until the area where grease was applied, is visible and able to reach.	
4	Apply grease on the highlighted area so that the cable package inside the tube is covered with cable grease all the way through.	 xx1400001390
5	Carefully push the cable package back in through the insert and into its mounting position in the tube.	
6	 Note Make sure the cables and hoses are not twisted through the upper arm.	

Connect the cable package



	Action	Note
1	 DANGER Turn off all: <ul style="list-style-type: none"> • electric power supply • hydraulic pressure supply • air pressure supply to the robot, before entering the safeguarded space.	
2	 CAUTION The cable package is sensitive to mechanical damage. Handle it with care in order to avoid damaging the cabling or the connectors.	

Continues on next page

4 Repair

4.2.2 Replacing the cable package IRBDP MH3 UI

Continued

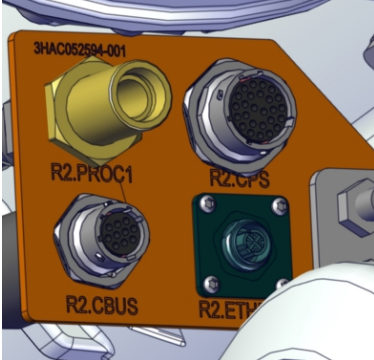
	Action	Note
3	<p>Connect the hose and cable connectors on the connection plate.</p> <p> CAUTION</p> <p>Do not tighten the brass couplings for water and air with excessive force.</p> <p> Tip</p> <p>Start connecting top connectors, and continue downwards.</p> <p> CAUTION</p> <p>If the M12 Ethernet connector is not tightened correctly, there is a risk that the connector can loosen and the cable shield gets disconnected, which will require retightening with the correct torque tools.</p> <p>For secure connection, always tighten at the knurled screw with correct torque and by using proper torque tool, e.g. M12 dynamometric screwdriver SW15 (09 99 000 0646 (article number at Harting Technology Group)).</p>	<p>Tightening torque:</p> <ul style="list-style-type: none"> • Brass coupling 1/2": 31 Nm. • Stainless steel coupling 1/2": 49 Nm. • Brass coupling 3/8": 17 Nm. • Mixed metals: Use the lower tightening torque value of the two metals. <p>Always apply Molykote P1900 to stainless steel couplings and apply if needed for couplings of mixed metals or brass.</p> <p>Tightening torque, Ethernet M12: 0.6 Nm.</p>  <p>xx1500003038</p>

Fitting cable package on the upper arm

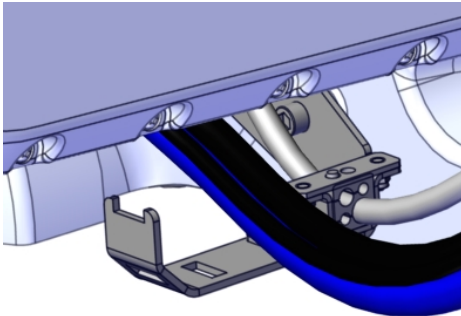
	Action	Note
1	<p>Secure the cable package to the mounting plate with a strap.</p>	 <p>xx1500003039</p>

Continues on next page

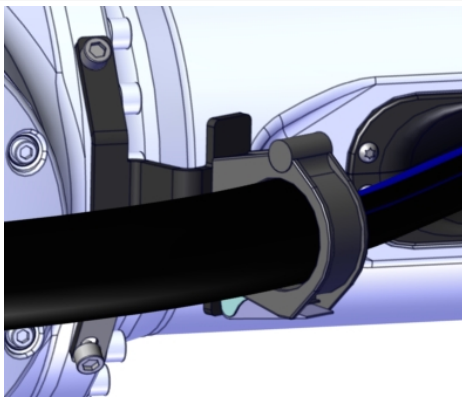
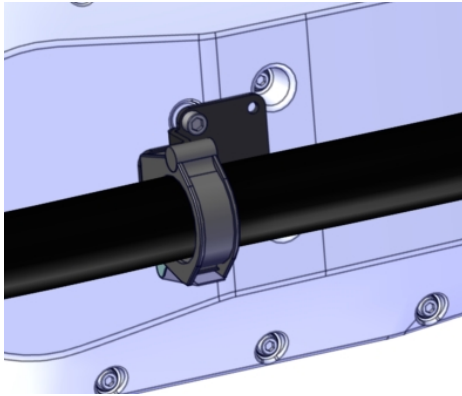
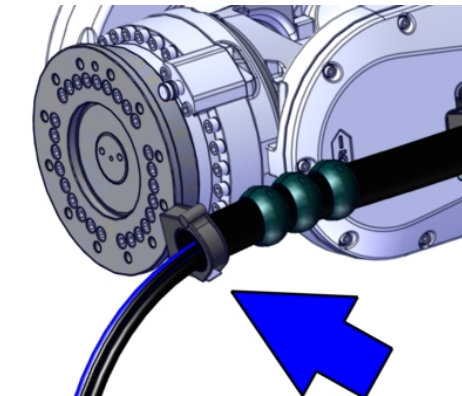
	Action	Note
2	Fasten the cable package in the gripping clamps on the upper arm.	 <p>xx1500003040</p>  <p>xx1500003041</p>
3	The gripping clamp at the front shall be fitted on equipment used by the customer.	 <p>xx1500003042</p>

Continues on next page

4 Repair

4.2.2 Replacing the cable package IRBDP MH3 UI

Continued

Check of protective sleeve

The protective hose is protected against wear in exposed areas with a protective sleeve.

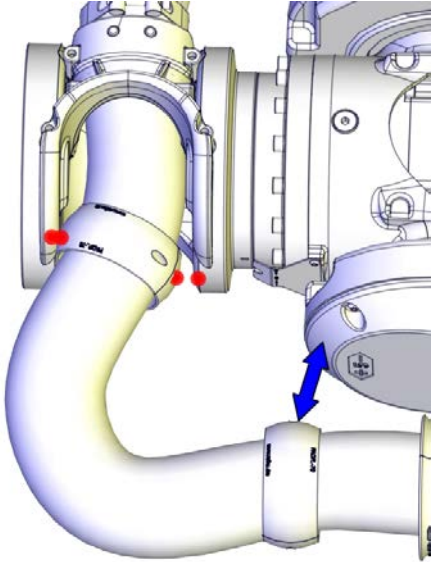
	Action	Note
1	In order to be sure that the protective sleeve is in the correct position, check the position after some hours running.	 <p>xx1400000224</p>
2	If the protective hose is worn somewhere, adjust the position of the protective sleeve.	

4.2.3 Replacing the cable package IRBDP MH LI

Location of the cable package

The cable package is located inside the lower arm.

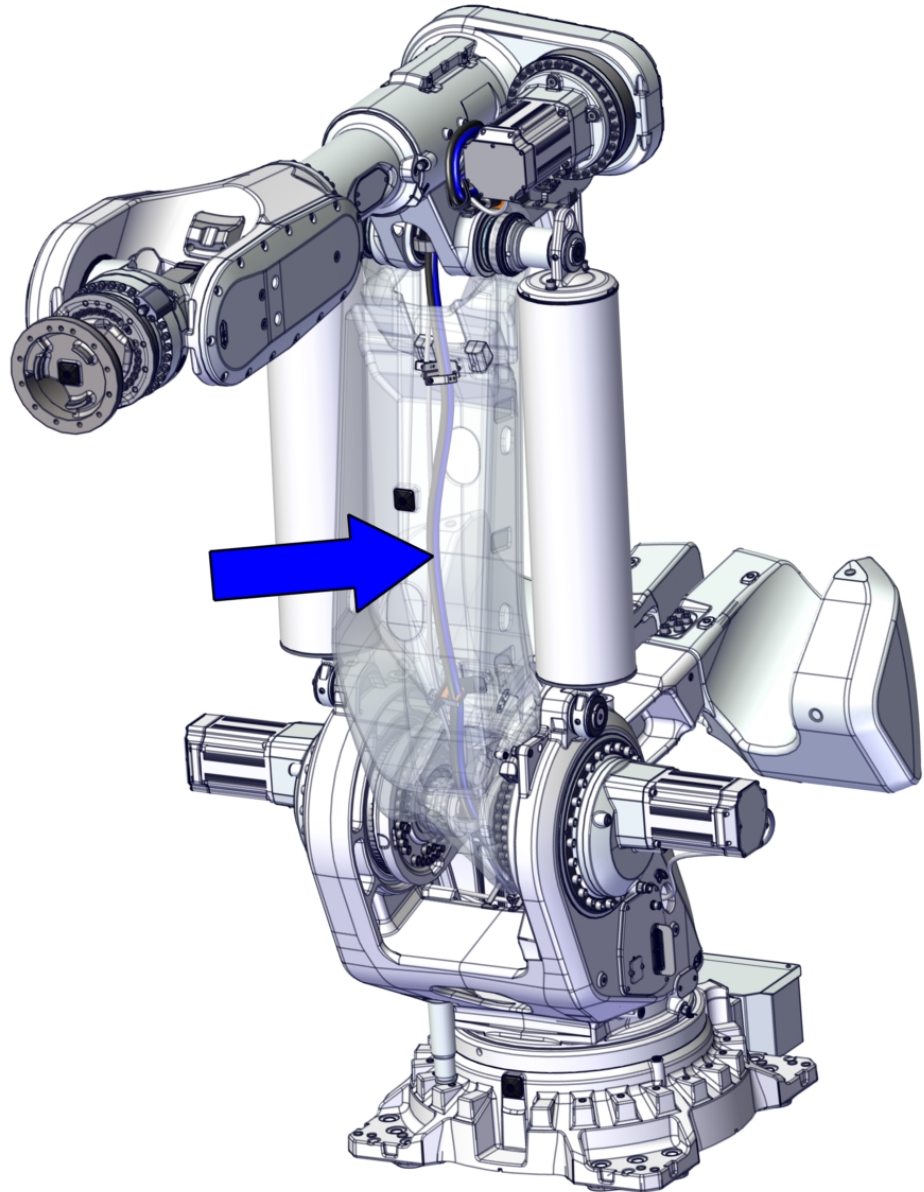

xx1500002962

Spare parts

The following equipment is required for the replacement of the lower arm cable package IRBDP MH LI.

Spare part	Spare part number	Note
Cable package IRBDP MH LI	Also see	

Continues on next page

4 Repair

4.2.3 Replacing the cable package IRBDP MH LI

Continued

Required tools and equipment



The following equipment is required for the replacement of the cable package IRBDP MH LI.

Equipment	Article number	Note
Standard toolkit, DressPack	3HAC17290-7	The contents are defined in section Toolkits, DressPack on page 213 .

Removing the cable package

Use this procedure to remove the cable package IRBDP MH LI.

Disconnecting the cable package

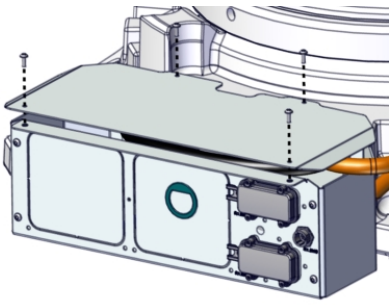
	Action	Note
1	 DANGER Turn off all: <ul style="list-style-type: none">• electric power supply• hydraulic pressure supply• air pressure supply to the robot, before entering the safeguarded space.	
2	 CAUTION The cable package is sensitive to mechanical damage. Handle it with care in order to avoid damaging the cabling or the connectors.	
3	Remove the rear cover plate.	 xx1500002963

Continues on next page

4.2.3 Replacing the cable package IRBDP MH LI
Continued

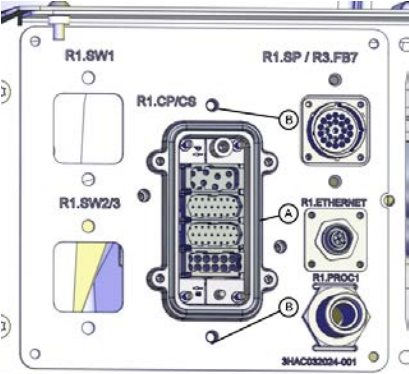
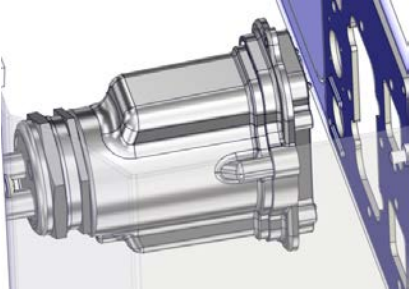
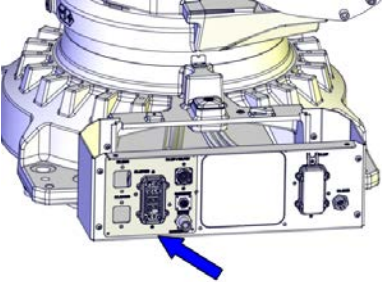
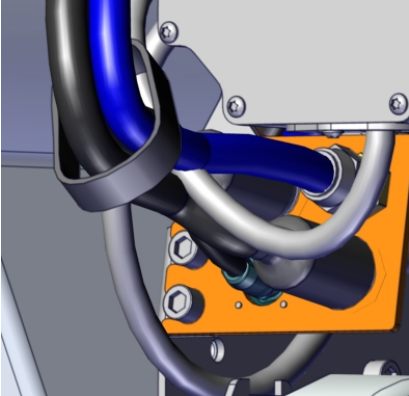
	Action	Note
4	Unscrew the screws that secure the R1.CP/CS connector.	 <p>xx1400001141</p> <p>A Screw M6x16 8.8-A2F (2 pcs) B R1.CP/CS connector</p>
5	Remove the R1.CP/CS connector.	 <p>xx1400001149</p>
6	Disconnect the connectors from the customer plate.	 <p>xx1400000081</p>
7	Disconnect the connectors at the connection plate.	 <p>xx1500003035</p>

Continues on next page

4 Repair

4.2.3 Replacing the cable package IRBDP MH LI

Continued

Removing the cable package

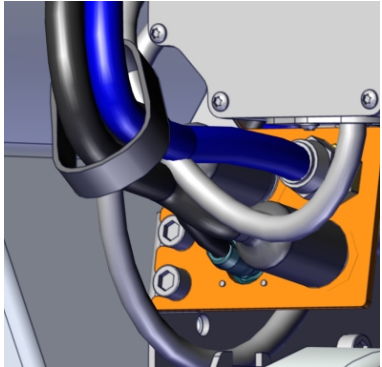
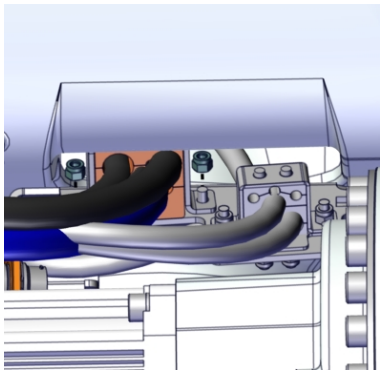
	Action	Note
1	Remove the strap.	 xx1500003035
2	Remove nuts holding the metal clamp.	 xx1500003033
3	Gently push the cabling into the lower arm.	

Continues on next page

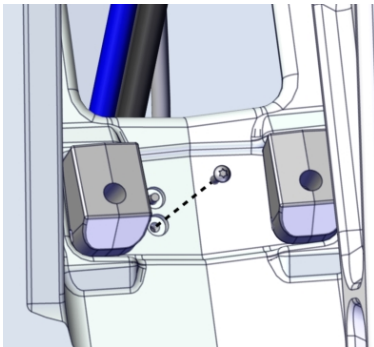
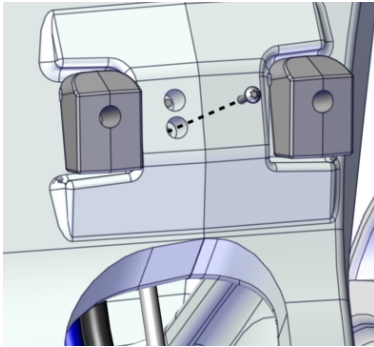
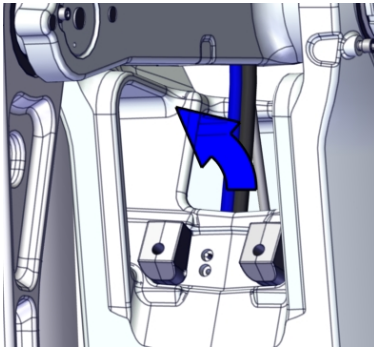
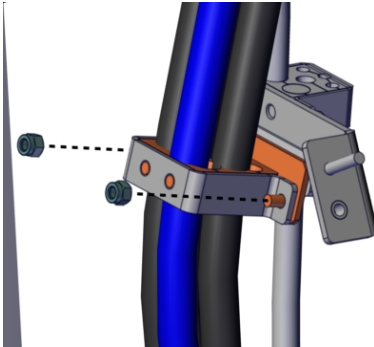
	Action	Note
4	Remove the screws holding the motor cabling brackets inside lower arm.	 <p>xx1500003019</p>  <p>xx1500003020 Figure 4.1:</p>
5	Gently pull the motor cabling upwards until the motor cabling bracket is reachable.	 <p>xx1500003024</p>
6	Remove nuts.	 <p>xx1500003025</p>

Continues on next page

4 Repair

4.2.3 Replacing the cable package IRBDP MH LI

Continued

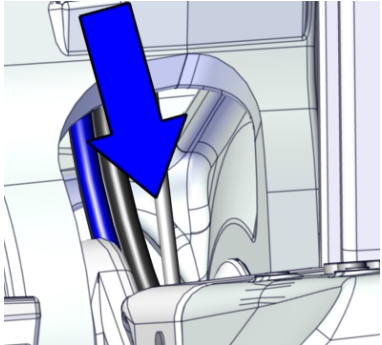
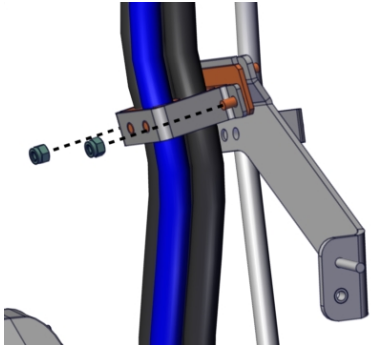
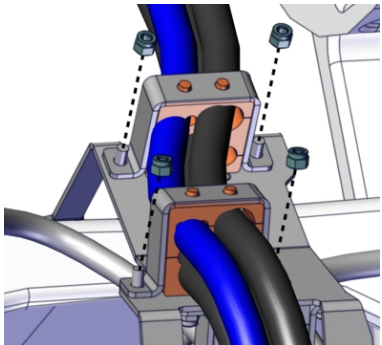

	Action	Note
7	Gently pull out the motor cabling downwards to be able to remove the dresspack cabling from the motor cabling bracket inside lower arm.	 xx1500003021
8	Remove nuts.	 xx1500003023
9	Remove the nuts on the motor cabling bracket.	 xx1500003022
10	Carefully pull out the cable package.	

Continues on next page

Refitting the cable package

Use this procedure to refit the cable package IRBDP MH LI.

Connecting the cable package

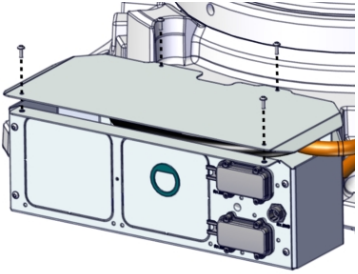
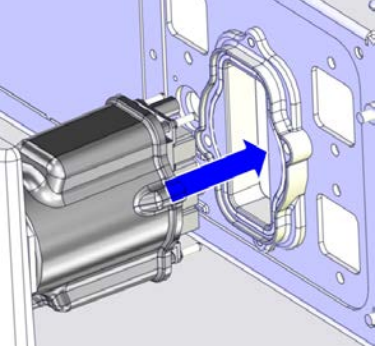

	Action	Note
1	 DANGER Turn off all: <ul style="list-style-type: none"> • electric power supply • hydraulic pressure supply • air pressure supply to the robot, before entering the safeguarded space.	
2	 CAUTION The cable package is sensitive to mechanical damage. Handle it with care in order to avoid damaging the cabling or the connectors.	
3	Remove the rear cover plate.	 <p>xx1500002963</p>
4	Fit the R1.CP/CS cable to the customer plate.	 <p>xx1400001142</p>

Continues on next page

4 Repair

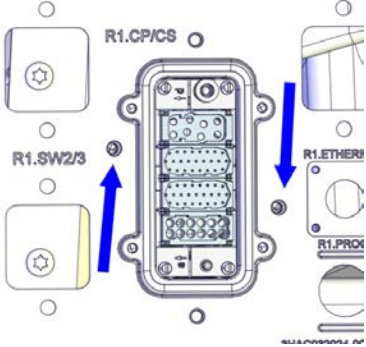

4.2.3 Replacing the cable package IRBDP MH LI

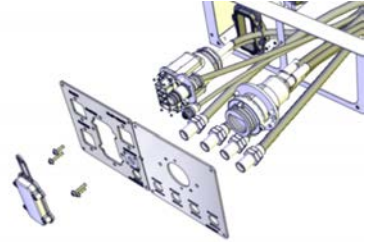
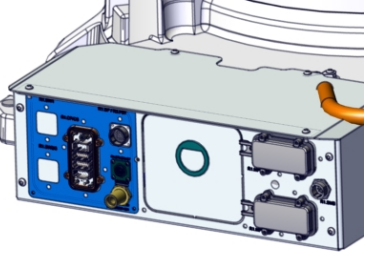
Continued

	Action	Note
5	Secure the R1.CP/CS connector.	 <p>xx1400001143 M6x25 A2-70 (2 pcs)</p>
6	<p>Connect the rest of the cable and hose connectors to the customer plate.</p> <p> CAUTION</p> <p>Do not tighten the brass couplings for water and air with excessive force.</p> <p> CAUTION</p> <p>Make sure that no cables or hoses are twisted or strained. Reroute if necessary.</p>	<p>Tightening torque:</p> <ul style="list-style-type: none"> • Brass coupling 1/2": 31 Nm. • Stainless steel coupling 1/2": 49 Nm. • Brass coupling 3/8": 17 Nm. • Mixed metals: Use the lower tightening torque value of the two metals. <p>Always apply Molykote P1900 to stainless steel couplings and apply if needed for couplings of mixed metals or brass.</p>  <p>xx1200000088</p>
7	Refit the rear cover plate.	 <p>xx1500002969</p>

Continues on next page

Refitting the cable package

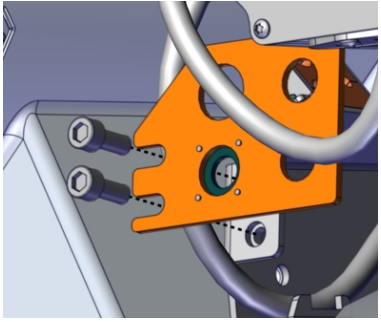
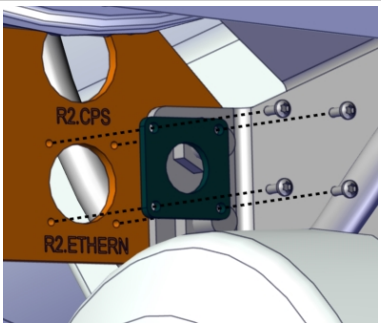
	Action	Note
1	<p> DANGER</p> <p>Turn off all:</p> <ul style="list-style-type: none"> • electric power supply • hydraulic pressure supply • air pressure supply <p>to the robot, before entering the safeguarded space.</p>	
2	<p> CAUTION</p> <p>The cable package is sensitive to mechanical damage. Handle it with care in order to avoid damaging the cabling or the connectors.</p>	
3	<p>Fit the connection plate. Lock screws with locking liquid.</p>	 <p>xx1500002970 M10x25 A2-7 0 (2 pcs)</p>
4	<p>Fasten the Profinet bracket.</p>	 <p>xx1500002971 M3x8 A2-70 (4 pcs)</p>

Continues on next page

4 Repair

4.2.3 Replacing the cable package IRBDP MH LI

Continued

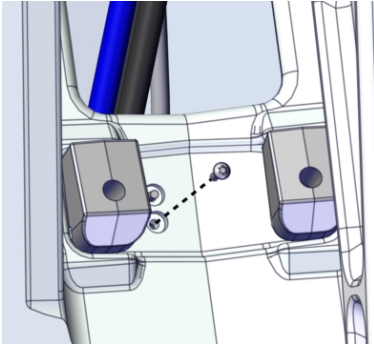
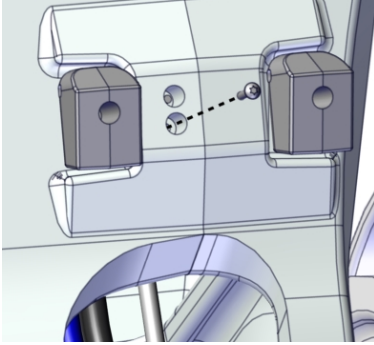
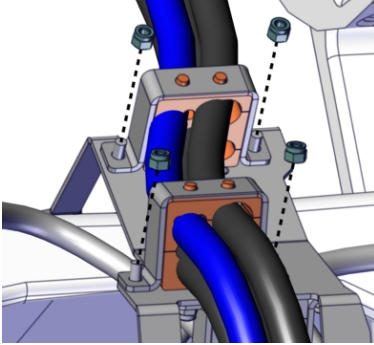
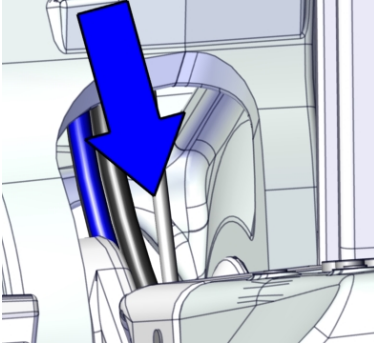
	Action	Note
5	Remove screws for motor cabling brackets inside the lower arm.	 xx1500003019  xx1500003020
6	Gently push the dresspack cables up into the lower arm.	
7	Fit the metal clamps on the motor cabling bracket.	 xx1500003022 M6 Steel 8-A2F (2x 2 pcs)
8	Gently pull out the motor cabling downwards to be able to fit the dresspack cables on the cabling bracket inside lower arm.	 xx1500003021

Continues on next page

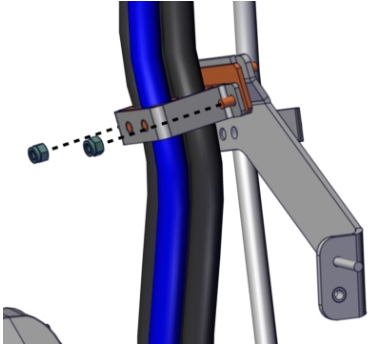
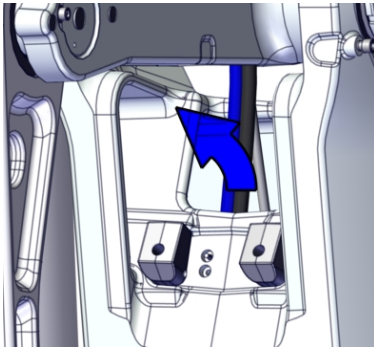
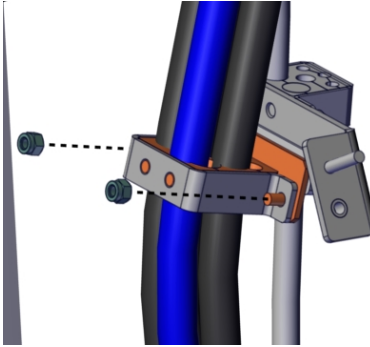
	Action	Note
9	Fit the metal clamp.	 <p data-bbox="1059 667 1166 685">xx1500003023</p> <p data-bbox="1059 696 1310 725">M6 Steel 8-A2F (2 pcs)</p>
10	Pull the motor cabling gently upwards until the motor cabling bracket is reachable.	 <p data-bbox="1059 1097 1166 1115">xx1500003024</p>
11	Fit the metal clamp.	 <p data-bbox="1059 1496 1166 1514">xx1500003025</p> <p data-bbox="1059 1525 1310 1554">M6 Steel 8-A2F (2 pcs)</p>

Continues on next page



4 Repair

4.2.3 Replacing the cable package IRBDP MH LI

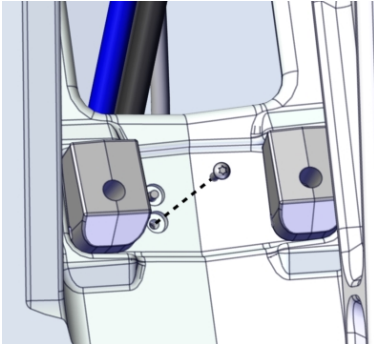
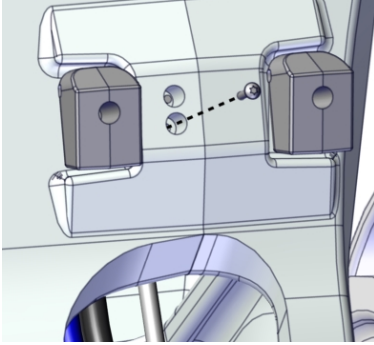
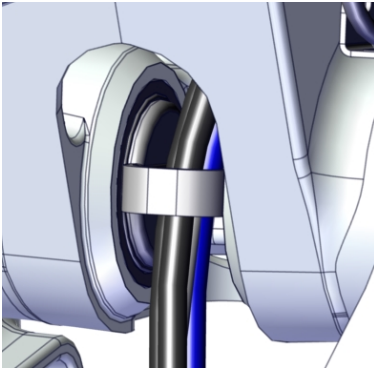
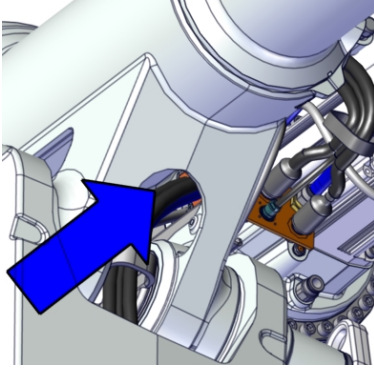
Continued

	Action	Note
12	Fit the motor cabling brackets inside lower arm.	 <p data-bbox="1029 667 1136 685">xx150003019</p>  <p data-bbox="1029 1055 1136 1072">xx150003020</p>
13	Place the cables in the cable guide.	 <p data-bbox="1029 1473 1136 1491">xx150003027</p>
14	Push the cables out of axis 3-4 beside the motor.	 <p data-bbox="1029 1895 1136 1912">xx150003032</p>

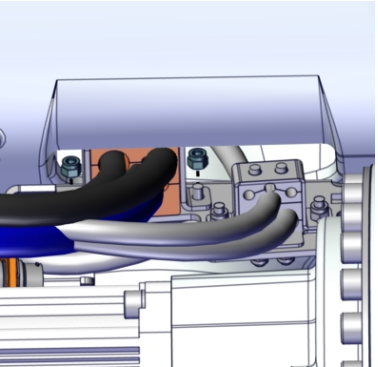
Continues on next page

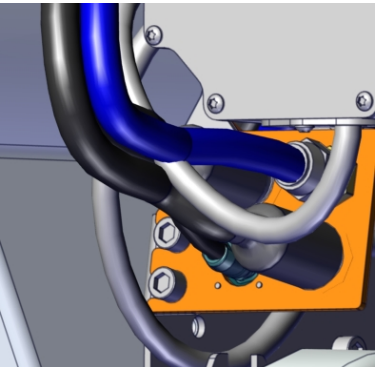
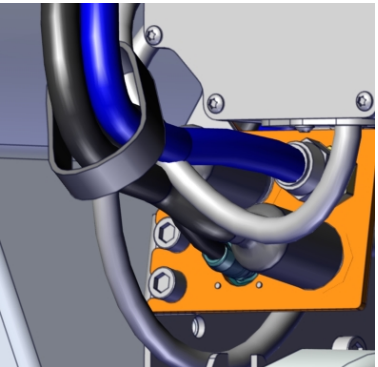
	Action	Note
15	Fit the metal clamp.	 <p>xx1500003033</p>
16	Carefully bend the cabling and attach it to the connection plate.  Tip Start connecting top connectors, and continue downwards.	 <p>xx1500003034</p>
17	Put a strap around the cabling.	 <p>xx1500003035</p>

4 Repair

4.2.4 Replacing the cable package IRBDP SW6 LI LeanID

4.2.4 Replacing the cable package IRBDP SW6 LI LeanID

Location

The DressPack cable package IRBDP SW6 LI, is located as shown in the figure.



xx1500002651

Spare parts

Spare part	Article number	Note
Cable package IRBDP SW6 LI	See DressPack cable package IRBDP SW6 LI on page 218	





Required tools and equipment

Equipment, etc.	Article number	Note
Standard toolkit	-	Content is defined in section Standard toolkit on page 213 .

Continues on next page

Removing the cable package -IRBDP SW6 LI

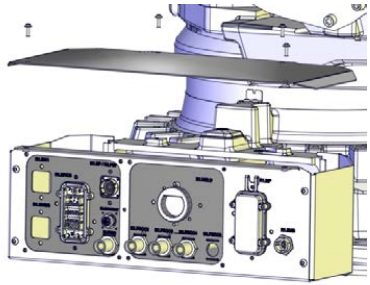
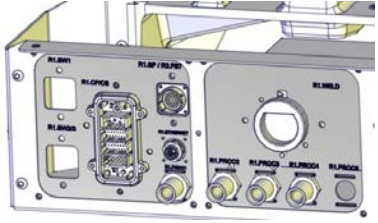
Disconnecting the cable package

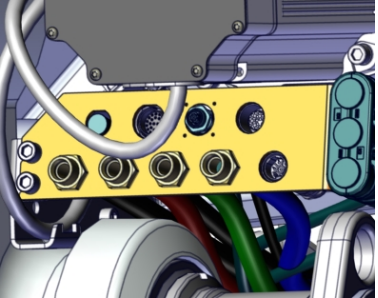
	Action	Note
1	Move the robot to a comfortable working position.	
2	 <p>DANGER</p> <p>Turn off all:</p> <ul style="list-style-type: none"> • electric power supply • hydraulic pressure supply • air pressure supply <p>to the robot, before entering the safeguarded space.</p>	
3	 <p>CAUTION</p> <p>The cable package is sensitive to mechanical damage. Handle it with care in order to avoid damaging the cabling or the connectors.</p>	
4	Remove the rear cover.	 <p>xx1400000197</p>
5	Disconnect connectors at the base.	 <p>xx1400000212</p>
6	<p>Disconnect connectors at the connection plate.</p>  <p>Note</p> <p>Do not disconnect the connectors of the cable package IRBDP SW6 LI. The connection plate is part of IRBDP SW6 LI.</p>	 <p>xx1500003049</p>

Continues on next page

4 Repair



4.2.4 Replacing the cable package IRBDP SW6 LI LeanID

Continued

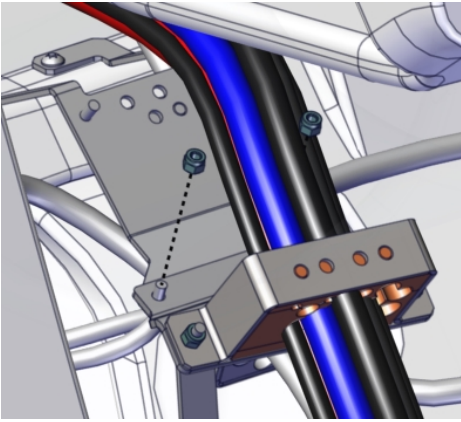
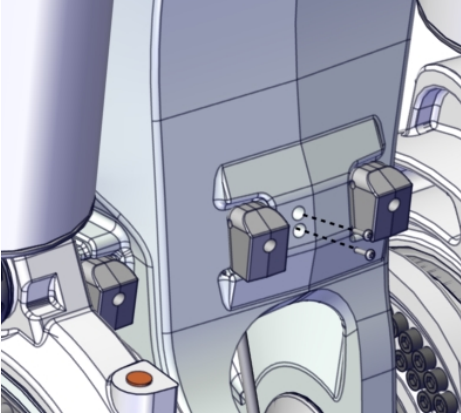
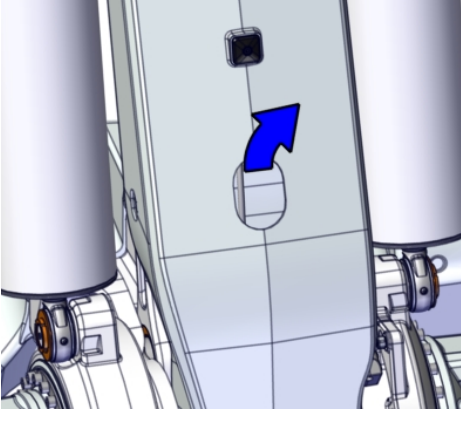
Removing the cable package

	Action	Note
1	Remove nuts inside frame.	 <p>xx1500002659</p>
2	Loosen screws in the back lower arm.	 <p>xx1500002606</p>
3	Carefully pull out the motor cabling with the bracket through the front hole on the lower arm.	 <p>xx1500002607</p>

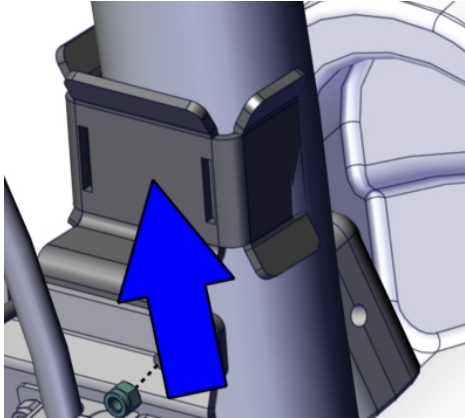
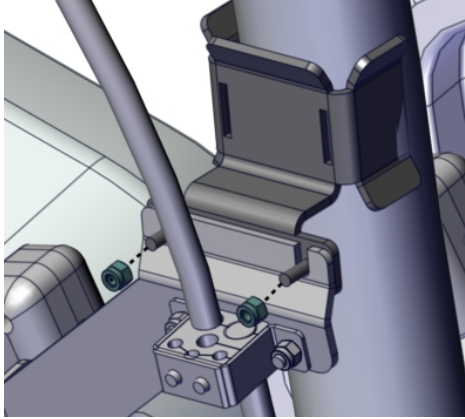
Continues on next page

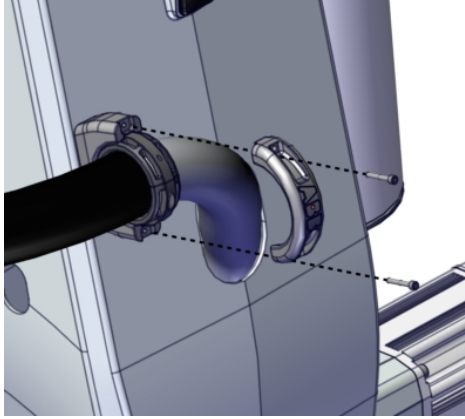



	Action	Note
4	Remove the velcro strap.	 <p>xx1500002657</p>
5	Remove nuts.	 <p>xx1500002655</p>
6	Remove upper part of ball joint housing.  Note Be careful not to loose the small o-ring! The purpose of the o-ring is to keep the screws in place in the housing, upper part.	 <p>xx1500002658</p>

Continues on next page

4 Repair

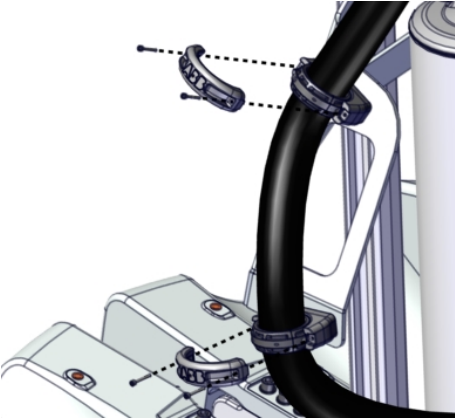
4.2.4 Replacing the cable package IRBDP SW6 LI LeanID

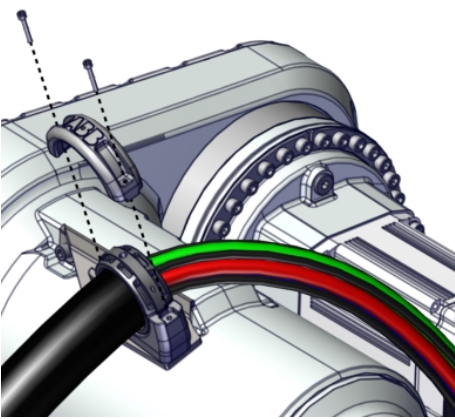
Continued

	Action	Note
7	<p>Remove upper part of ball joint housings.</p> <p> Note</p> <p>Be careful not to loose the small o-ring! The purpose of the o-ring is to keep the screws in place in the housing, upper part.</p>	 <p>xx1500002654</p>
8	<p>Remove upper part of ball joint housing.</p> <p> Note</p> <p>Be careful not to loose the small o-ring! The purpose of the o-ring is to keep the screws in place in the housing, upper part.</p>	 <p>xx1500002653</p>
9	<p>Carefully pull out the cable package.</p> <p> Tip</p> <p>This is best done following this order:</p> <ul style="list-style-type: none"> • Hoses • Weld cables • Motor cables 	

Refitting the cable package - IRBDP SW6 LI

Use this procedure to refit the cable package.



Preparations

	Action	Note
1	Move the robot to a comfortable working position.	

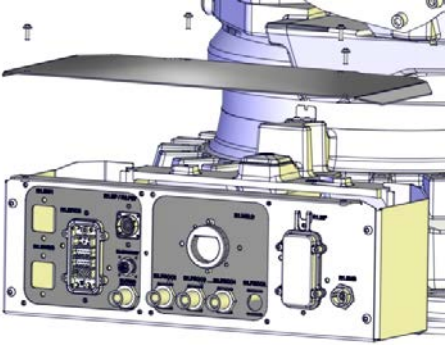
Continues on next page

	Action	Note
2	<p> DANGER</p> <p>Turn off all:</p> <ul style="list-style-type: none"> • electric power supply • hydraulic pressure supply • air pressure supply <p>to the robot, before entering the safe-guarded space.</p>	
3	<p>Remove the rear cover plate (if not already removed).</p>	 <p>xx140000197</p>

Fasten the cable package



	Action	Note
1	<p> DANGER</p> <p>Turn off all:</p> <ul style="list-style-type: none"> • electric power supply • hydraulic pressure supply • air pressure supply <p>to the robot, before entering the safe-guarded space.</p>	
2	<p> CAUTION</p> <p>The cable package is sensitive to mechanical damage. Handle it with care in order to avoid damaging the cabling or the connectors.</p>	
3	<p>Start the assembly of the cabling at the connector plate in axis 3-4. Let the cabling rest over the robots axis 3-4.</p>	

Continues on next page



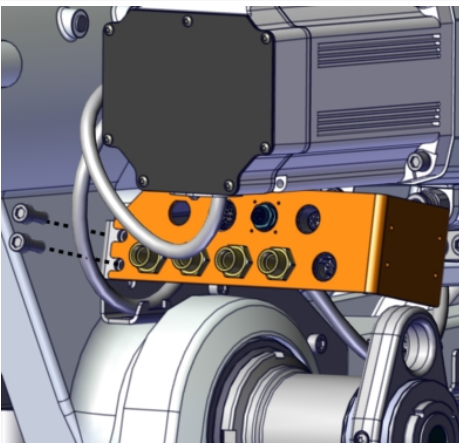
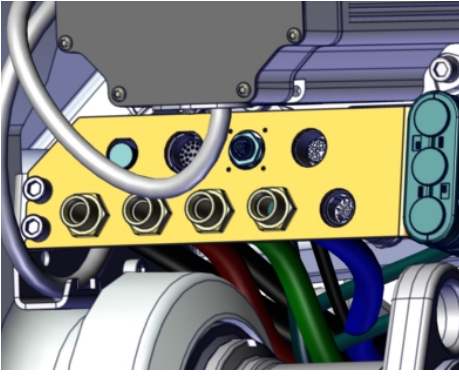

4 Repair

4.2.4 Replacing the cable package IRBDP SW6 LI LeanID

Continued

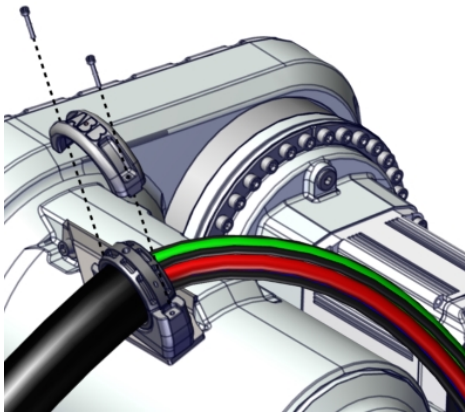
	Action	Note
4	Fasten the connector plate.	 <p data-bbox="943 757 1404 824">xx1500002652 M10x25 8.8-A3F (2 pcs)</p>
5	Connect the connectors.	 <p data-bbox="943 1216 1404 1240">xx1500003049</p>
6	 CAUTION Do not change the position of the clamp inserts on the protection hose, being fitted in the ball joint housings. If the position is changed it will alter the bending movement of the protection hose, when the arms are moved. A change of position of the clamp inserts may result in serious damage to the cable package.	

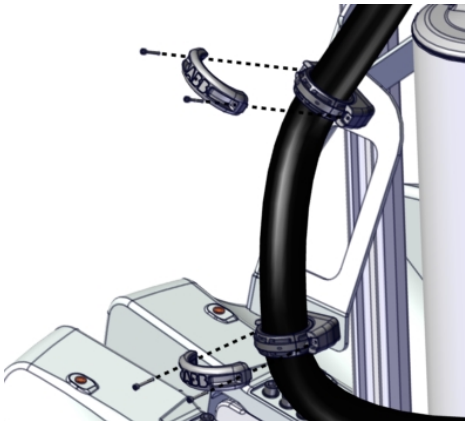
Continues on next page

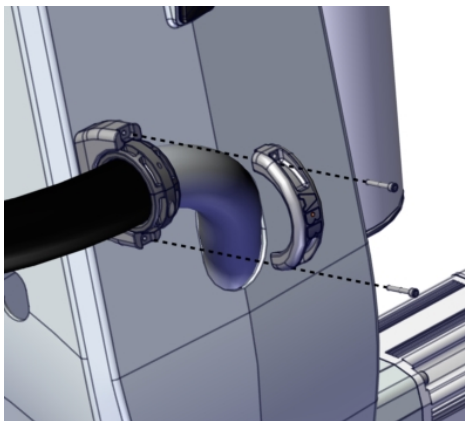
	Action	Note
7	<p>Fasten the cabling in the axis-3 ball joint housing.</p> <p> Note</p> <p>Be careful not to loose the small o-ring! The purpose of the o-ring is to keep the screws in place in the housing, upper part.</p>	 <p>xx1500002653 M8x16 8.8-A2F (2 pcs)</p>
8	<p>Fasten the cabling in the ball joint housings on the lower arm bracket.</p> <p> Note</p> <p>Be careful not to loose the small o-ring! The purpose of the o-ring is to keep the screws in place in the housing, upper part.</p>	 <p>xx1500002654 M8x16 8.8-A2F (2x 2 pcs)</p>
9	<p>Fasten the cabling in the ball joint housings on the lower arm.</p> <p> Note</p> <p>Be careful not to loose the small o-ring! The purpose of the o-ring is to keep the screws in place in the housing, upper part.</p>	 <p>xx1500002658 M8x16 8.8-A2F (2 pcs)</p>

Continues on next page

4 Repair

4.2.4 Replacing the cable package IRBDP SW6 LI LeanID

Continued

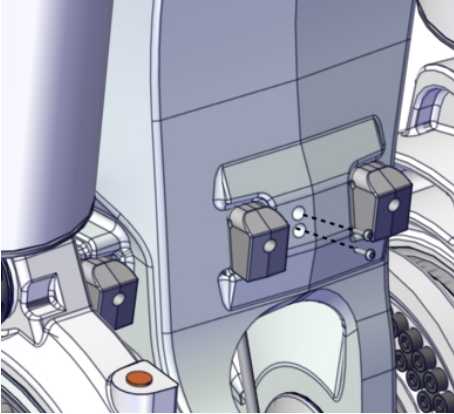
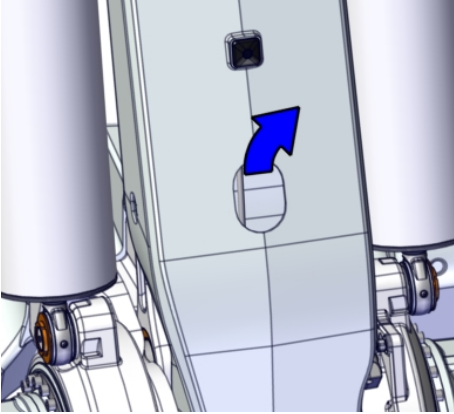
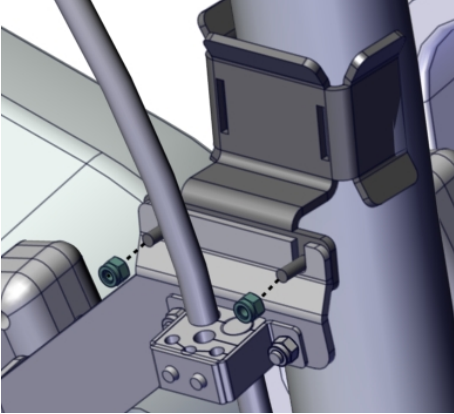
	Action	Note
10	Loosen the screws on the back lower arm. Save the screws for re-assembly.	 xx1500002606
11	Carefully pull out the motor cabling with the bracket through the front hole on the lower arm.	 xx1500002607
12	Fasten the IRBDP SW6 LE cabling bracket on the motor cabling bracket.	 xx1500002655 Prev. torque nut M6 (2 pcs)

Continues on next page

4.2.4 Replacing the cable package IRBDP SW6 LI LeanID

Continued

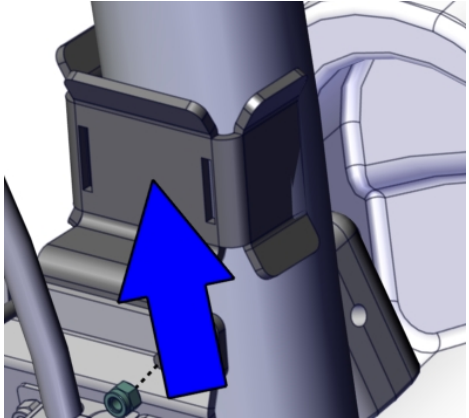
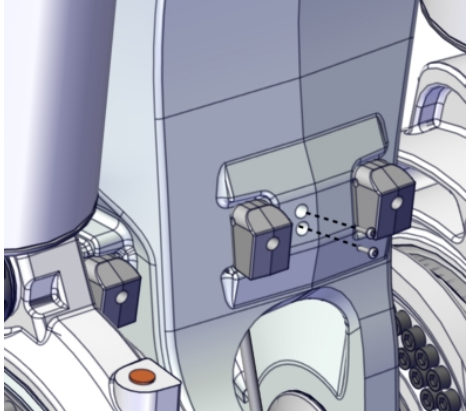
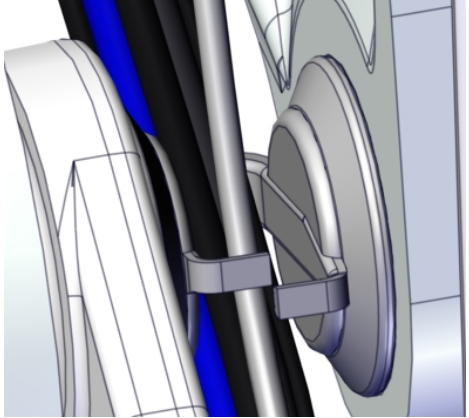
Action	Note
<p>13 Fasten a velcro strap around the bracket and the cabling.</p>	 <p>xx1500002657</p>
<p>14 Carefully push the cabling down through the lower arm.</p>	
<p>15 Fasten the bracket in the back lower arm. Use previously removed screws.</p>	 <p>xx1500002606</p>
<p>16 Put the cabling through the cable guide in axis 2.</p>	 <p>xx1500002656</p>

Continues on next page



4 Repair

4.2.4 Replacing the cable package IRBDP SW6 LI LeanID

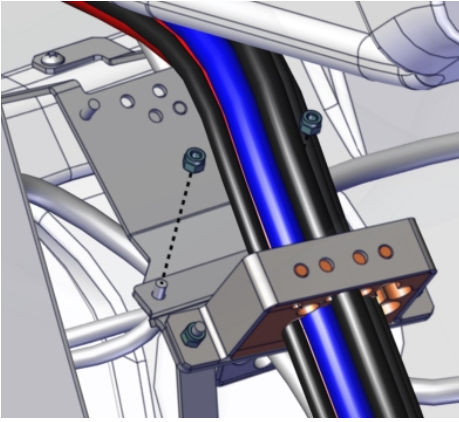
Continued

	Action	Note
17	Fasten the IRBDP cabling on the cabling bracket in the frame.	 <p>xx1500002659</p> <p>Prev. torque nut M6 (2 pcs)</p>
18	Run the cables down through the center hole of axis 1, in the following order: <ul style="list-style-type: none"> • Signal cables (Spot welding) • Hoses • Make a check that cables and hoses do not cross each other. 	

Connect the lower cable package at the base

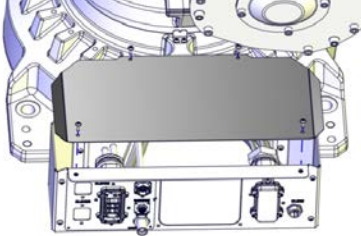
	Action	Note
1	 <p>DANGER</p> <p>Turn off all:</p> <ul style="list-style-type: none"> • electric power supply • air pressure supply <p>to the robot, before starting the repair work on the robot.</p>	
2	 <p>CAUTION</p> <p>The cable package is sensitive to mechanical damage. Handle it with care in order to avoid damaging the cabling or the connectors.</p>	
3	Remove the rear cover plate.	 <p>xx1400000080</p>

Continues on next page

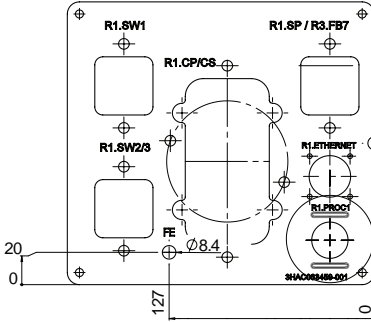
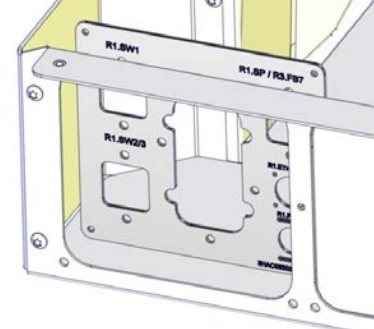
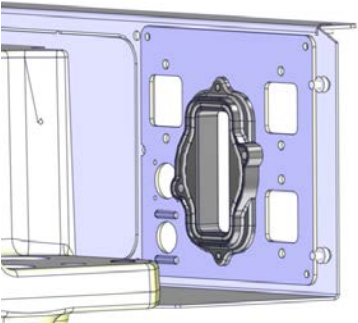
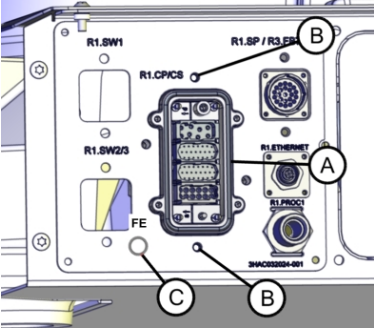
	Action	Note
4	<p>Only for Paramulti DressPack and for spare part replacement.</p> <p>The Paramulti DressPack spare part includes functional ground. If the installed DressPack has not included functional ground previously, following action needs to be done:</p> <p>Drill an 8.4 mm mm hole in the customer plate according to the figure.</p>	 <p>xx1900001268</p>
5	<p>Fit the customer plate.</p>	 <p>xx1400001146</p> <p>M6x16 8.8-A2F (4 pcs)</p>
6	<p>Fit the adapter complete to the customer plate.</p>	 <p>xx1400001140</p>
7	<p>Fasten the adapter complete to the customer plate.</p>	 <p>xx1400001141</p> <p>Parts:</p> <ul style="list-style-type: none"> • A: Adapter complete • B: M6x16 8.8-A2F (2 pcs) • C: Functional ground

Continues on next page

4 Repair

4.2.4 Replacing the cable package IRBDP SW6 LI LeanID

Continued

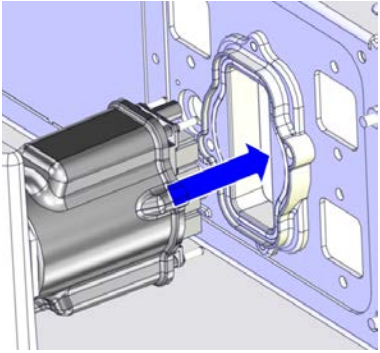
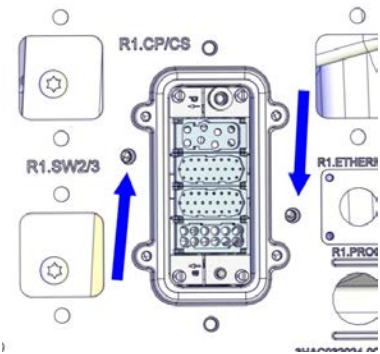
	Action	Note
8	Fit the R1.CP/CS cable to the customer plate.	 <p>xx1400001142</p>
9	Secure the R1.CP/CS connector.	 <p>xx1400001143</p> <p>M6x25 8.8-A2F (2 pcs)</p>
10	<p>Connect the rest of the cable and hose connectors to the customer plate.</p> <p>Only for Paramulti DressPack: Also connect functional ground.</p> <p>! CAUTION</p> <p>Do not tighten the brass couplings for water and air with excessive force.</p> <p>! CAUTION</p> <p>Make sure that no cables or hoses are twisted or strained. Reroute if necessary.</p> <p>! CAUTION</p> <p>If the M12 Ethernet connector is not tightened correctly, there is a risk that the connector can loosen and the cable shield gets disconnected, which will require retightening with the correct torque tools.</p> <p>For secure connection, always tighten at the knurled screw with correct torque and by using proper torque tool, e.g. M12 dynamometric screwdriver SW15 (09 99 000 0646 (article number at Harting Technology Group)).</p>	<p>Tightening torque:</p> <ul style="list-style-type: none"> • Brass coupling 1/2": 31 Nm. • Stainless steel coupling 1/2": 49 Nm. • Brass coupling 3/8": 17 Nm. • Mixed metals: Use the lower tightening torque value of the two metals. <p>Always apply Molykote P1900 to stainless steel couplings and apply if needed for couplings of mixed metals or brass.</p> <p>Tightening torque, Ethernet M12: 0.6 Nm.</p>

4.2.5 Replacing the cable packages IRBDP SW6 UI and IRBDP MH6 UI LeanID

Location of the cable package IRBDP SW6 UI and IRBDP MH6 UI

The cable packages IRBDP SW6 UI and IRBDP MH6 UI, are located as shown in the figure. The figure shows cable package IRBDP SW6 UI. The principle of IRBDP MH6 UI is the same as IRBDP SW6 UI.

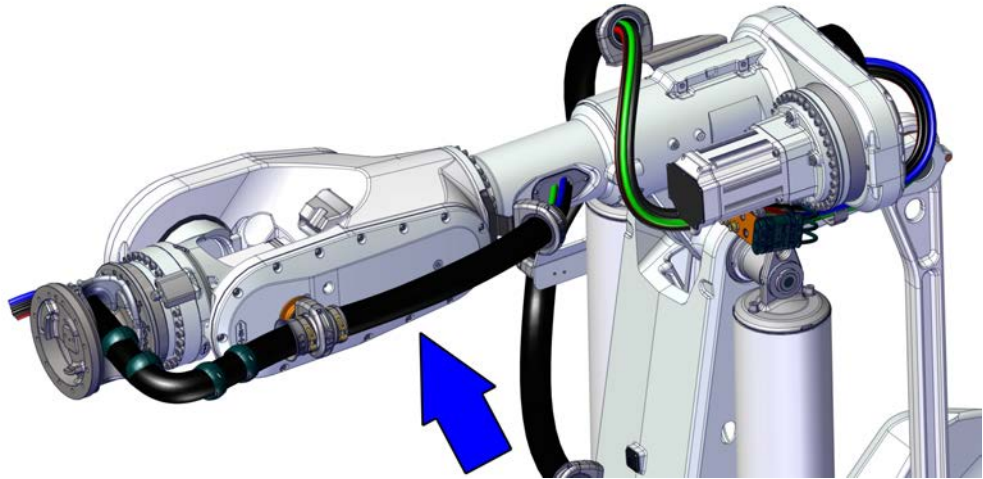

xx1500002777

Spare parts

Equipment, etc.	Article number	Note
Cable package IRBDP SW6 UI	See DressPack cable package IRBDP SW6 UI on page 219	
Cable package IRBDP MH6 UI	See DressPack cable package IRBDP SW6 LI on page 218	

Required tools and equipment

Equipment, etc.	Article number	Note
Standard toolkit	-	Content is defined in section Standard toolkit on page 213 .

Removing cable packages IRBDP SW6 UI and IRBDP MH6 UI

Use this procedure to remove the cable packages IRBDP SW6 UI and IRBDP MH6 UI.

Disconnecting the cable package



	Action	Note
1	Move the robot to a comfortable working position.	

Continues on next page

4 Repair

4.2.5 Replacing the cable packages IRBDP SW6 UI and IRBDP MH6 UI LeanID

Continued

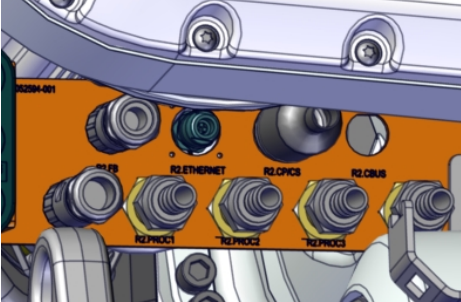
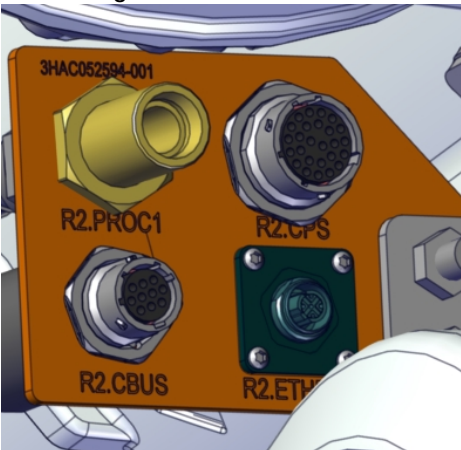
	Action	Note
2	<p> DANGER</p> <p>Turn off all:</p> <ul style="list-style-type: none"> • electric power supply • hydraulic pressure supply • air pressure supply <p>to the robot, before entering the safe-guarded space.</p>	
3	<p> CAUTION</p> <p>The cable package is sensitive to mechanical damage. Handle it with care in order to avoid damaging the cabling or the connectors.</p>	
4	<p>Disconnect hose and cable connectors on the connection plate.</p>	<p>SW-cabling:</p>  <p>xx1500002812</p> <p>MH-cabling:</p>  <p>xx1500003038</p>

Continues on next page

4.2.5 Replacing the cable packages IRBDP SW6 UI and IRBDP MH6 UI LeanID
Continued

Disconnecting the weld connector

Only valid for IRBDP SW6 UI.

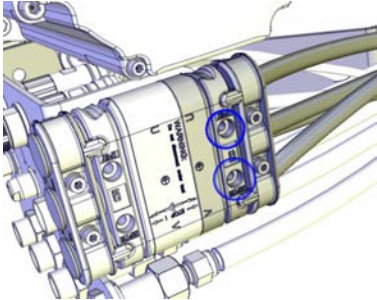
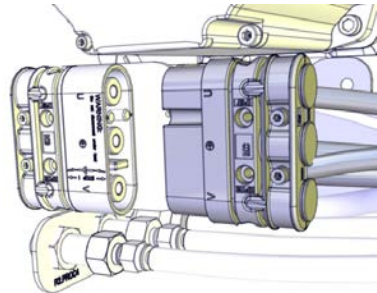
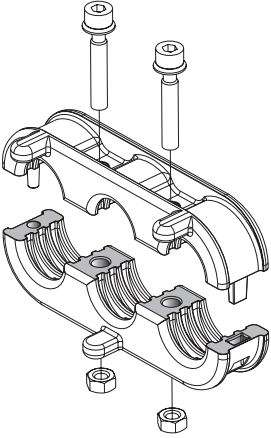
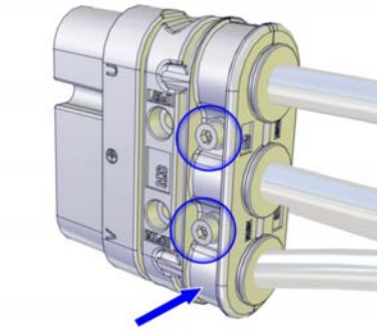
	Action	Note
1	Remove the screws securing the weld connector to the connection plate.	 <p>xx120000089 Screw, M5x40 8.8-A2F (2 pcs)</p>
2	Disconnect the weld connector.	 <p>xx120000075</p>
3	Remove the cable strain relief.  <p>xx1300000836 Figure 4.2:</p>	 <p>xx120000058 Screw, M5x25 8.8-A2F (2 pcs)</p>

Continues on next page



4 Repair

4.2.5 Replacing the cable packages IRBDP SW6 UI and IRBDP MH6 UI LeanID

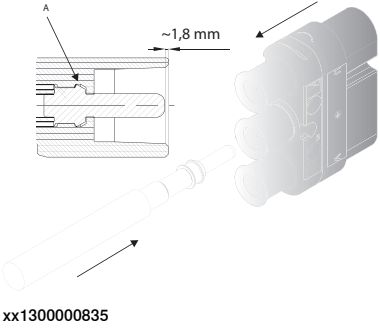
Continued

	Action	Note
4	<p>Unplug the connectors in the weld connector. Manually pull the cables with the crimped-on contact part out of the insulation.</p> <p> Note</p> <p>The unplugging will facilitate the removal of the cable package through the tube in the upper arm.</p>	

Removing the cable package

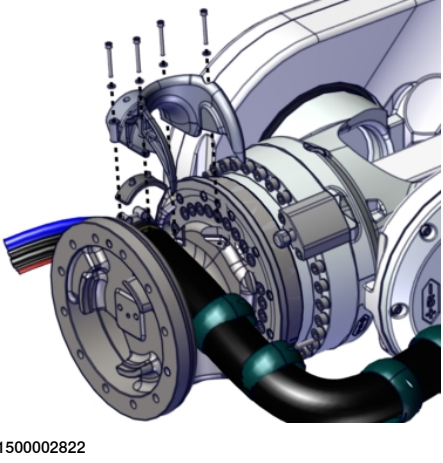
	Action	Note
1	<p> DANGER</p> <p>Turn off all:</p> <ul style="list-style-type: none"> • electric power supply • hydraulic pressure supply • air pressure supply <p>to the robot, before entering the safe-guarded space.</p>	
2	<p> CAUTION</p> <p>The cable package is sensitive to mechanical damage. Handle it with care in order to avoid damaging the cabling or the connectors.</p>	
3	<p>Only valid for IRBDP SW6 UI: Remove the cable package from the process turning disc cable guide.</p> <p> Note</p> <p>There is cable grease in the turning disc cable guide.</p>	

Continues on next page

4.2.5 Replacing the cable packages IRBDP SW6 UI and IRBDP MH6 UI LeanID
Continued

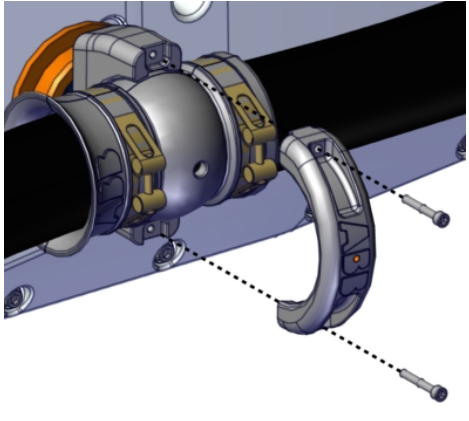
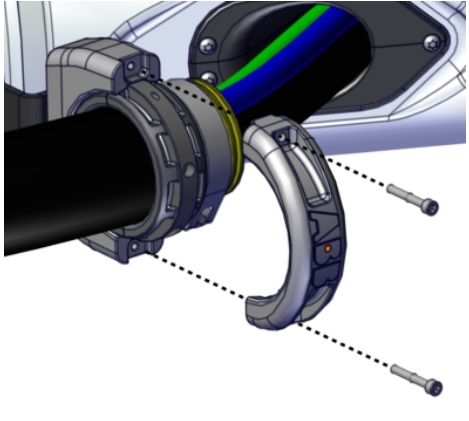
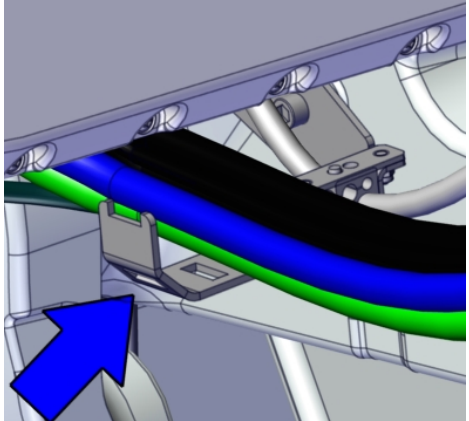

	Action	Note
4	<p>Remove upper part of ball joint housing.</p> <p> Note</p> <p>Be careful not to loose the small o-ring! The purpose of the o-ring is to keep the screws in place in the housing, upper part.</p>	 <p>xx1500002820</p>  <p>xx1500002819</p>
5	<p>Remove the velcro strap.</p>	 <p>xx1500002818</p>

Continues on next page

4 Repair

4.2.5 Replacing the cable packages IRBDP SW6 UI and IRBDP MH6 UI LeanID

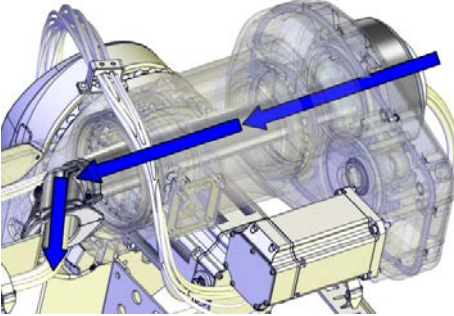

Continued

	Action	Note
6	<p>Carefully pull the cable package out of the tube and insert.</p> <p> Note</p> <p>There is cable grease on the cables.</p> <p> Tip</p> <p>This operation is best performed by two persons working together.</p>	 <p>xx140000188</p>

Refitting cable packages IRBDP SW6 UI and IRBDP MH6 UI

Use this procedure to refit the cable packages IRBDP SW6 UI and IRBDP MH6 UI.

Route the cable package

	Action	Note
1	<p>Move the robot to a comfortable working position.</p>	
2	<p> DANGER</p> <p>Turn off all:</p> <ul style="list-style-type: none"> • electric power supply • hydraulic pressure supply • air pressure supply <p>to the robot, before entering the safeguarded space.</p>	
3	<p> CAUTION</p> <p>The cable package is sensitive to mechanical damage. Handle it with care in order to avoid damaging the cabling or the connectors.</p>	
4	<p> Tip</p> <p>This procedure is best done by two persons working together - one pushing cabling and hoses into the tube and the other pulling them out at the wrist.</p>	

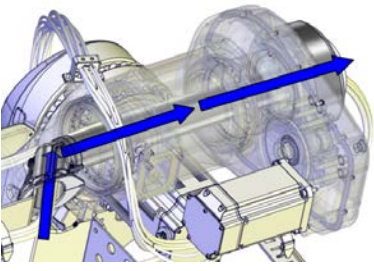

Continues on next page

4.2.5 Replacing the cable packages IRBDP SW6 UI and IRBDP MH6 UI LeanID
Continued

	Action	Note
5	<p>Carefully push the cable package into the insert, through the tube and out in the back of the arm housing.</p> <p> Tip</p> <p>The following order is preferable:</p> <ol style="list-style-type: none"> 1 Cables 2 Hoses 3 Weld cables (where applicable) <p>If there is a problem, remove the nut inside the tube.</p>	 <p>xx140000095</p>

Apply cable grease

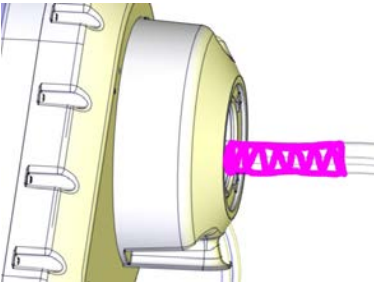
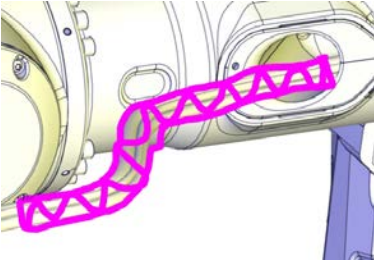
It is necessary to apply cable grease on the cable package inside the tube.

	Action	Note
1	<p>Carefully pull the cable package out 10 to 15 centimeters longer than the final assembly position.</p>	
2	<p>Apply grease on the highlighted area.</p>	 <p>xx1400001389</p>
3	<p>Carefully push the cable package back into the tube and out through the insert until the area where grease was applied, is visible and able to reach.</p>	
4	<p>Apply grease on the highlighted area so that the cable package inside the tube is covered with cable grease all the way through.</p>	 <p>xx1400001390</p>
5	<p>Carefully push the cable package back in through the insert and into its mounting position in the tube.</p>	
6	<p> Note</p> <p>Make sure the cables and hoses are not twisted through the upper arm.</p>	



Continues on next page

4 Repair

4.2.5 Replacing the cable packages IRBDP SW6 UI and IRBDP MH6 UI LeanID

Continued

Connect the cable package

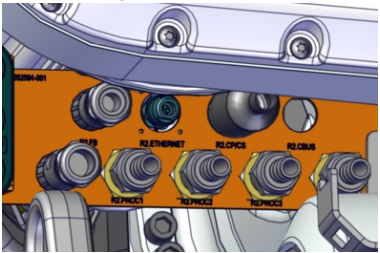
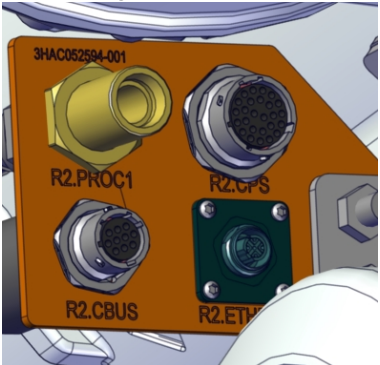
	Action	Note
1	<p>Connect the hose and cable connectors on the connection plate.</p> <p> CAUTION</p> <p>Do not tighten the brass couplings for water and air with excessive force.</p> <p> Tip</p> <p>Start connecting top connectors, and continue downwards.</p> <p> CAUTION</p> <p>If the M12 Ethernet connector is not tightened correctly, there is a risk that the connector can loosen and the cable shield gets disconnected, which will require retightening with the correct torque tools.</p> <p>For secure connection, always tighten at the knurled screw with correct torque and by using proper torque tool, e.g. M12 dynamometric screwdriver SW15 (09 99 000 0646 (article number at Harting Technology Group)).</p>	<p>Tightening torque:</p> <ul style="list-style-type: none"> • Brass coupling 1/2": 31 Nm. • Stainless steel coupling 1/2": 49 Nm. • Brass coupling 3/8": 17 Nm. • Mixed metals: Use the lower tightening torque value of the two metals. <p>Always apply Molykote P1900 to stainless steel couplings and apply if needed for couplings of mixed metals or brass.</p> <p>Tightening torque, Ethernet M12: 0.6 Nm.</p> <p>SW-cabling:</p>  <p>xx1500002812</p> <p>MH-cabling:</p>  <p>xx1500003038</p>

Continues on next page

4.2.5 Replacing the cable packages IRBDP SW6 UI and IRBDP MH6 UI LeanID
Continued

Weld connector

Only valid for IRBDP SW6 UI.

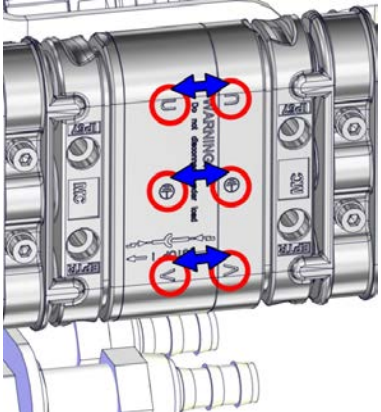
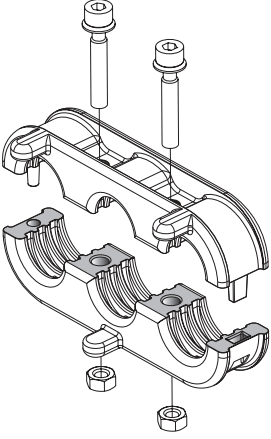
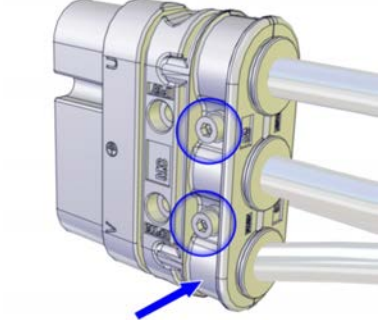
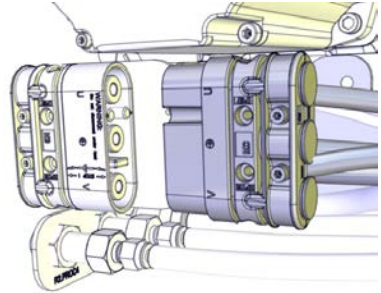
	Action	Note
1	<p>Press (manually) the cables with the crimped-on contact part into the insulation from the back until it perceptibly engages into place to the detent.</p> <p> Note Make sure the pins are pushed all the way into the connector.</p>	 <p>xx1400000216</p>
2	<p>Fit the cable strain relief.</p>  <p>xx1300000836</p>	 <p>xx1200000058 M5x25 8.8-A2F (2 pcs)</p>
3	<p>Connect the weld cable.</p>	 <p>xx1200000075</p>

Continues on next page

4 Repair

4.2.5 Replacing the cable packages IRBDP SW6 UI and IRBDP MH6 UI LeanID

Continued

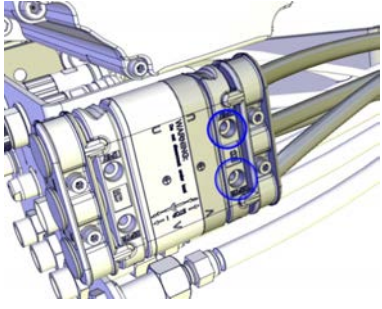

	Action	Note
4	Fasten the weld connector to the connection plate.	 xx120000089 M5x40 8.8-A2F (2 pcs)

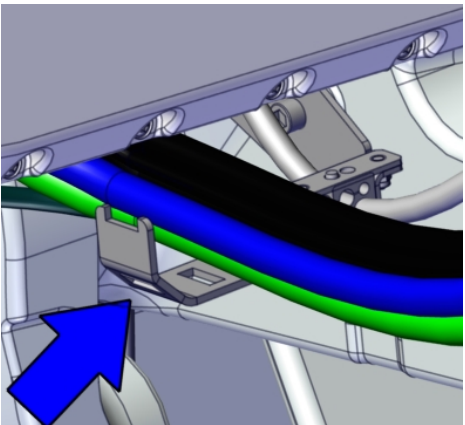
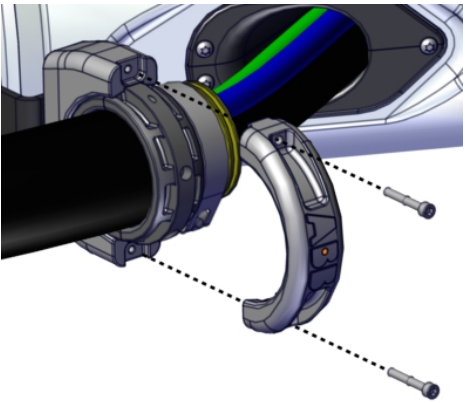
Fasten the cable package IRBDP SW6 UI and IRBDP MH6 UI

	Action	Note
1	Fasten the cable package to the bracket with a strap.	 xx1500002818
2	Fasten the cable package in the ball joint housing.	 xx1500002819 M8x16 A2-7 0 (2 pcs)

Continues on next page

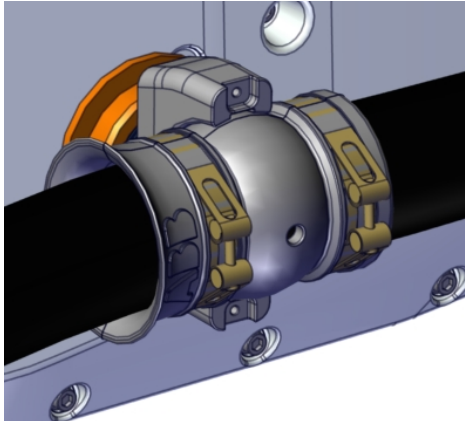
4.2.5 Replacing the cable packages IRBDP SW6 UI and IRBDP MH6 UI LeanID
Continued

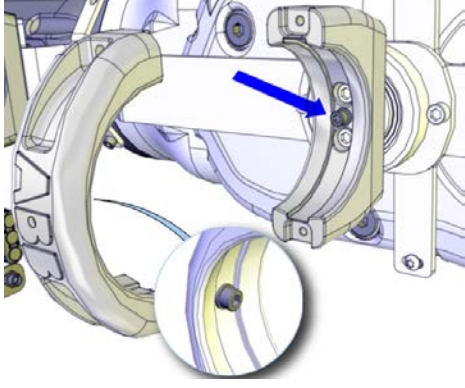
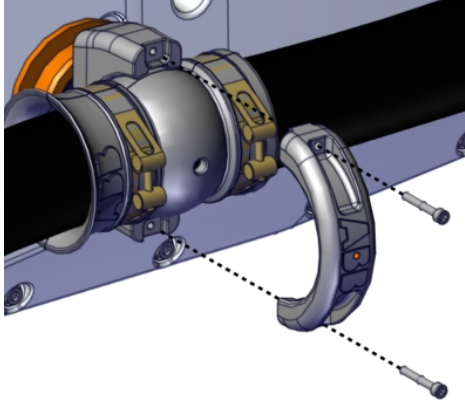

	Action	Note
3	<p>Make sure that the hose reinforcement funnel is fitted correctly, in the direction shown in the figure.</p>	 <p>xx1500002821</p>
4	<p>Make sure that the screws (M6x12) fits into the guiding holes of the hose reinforcement funnel when it is fitted in the ball joint housing.</p> <p> CAUTION</p> <p>The hose reinforcement funnel must not be able to rotate inside the ball joint housing when fitted.</p>	 <p>xx1200000153 M6x12 8.8-A2F (1 pc)</p>
5	<p>Fasten the cable package in the ball joint housing.</p>	 <p>xx1500002820 M8x16 A2-7 0 (2 pcs)</p>
6	<p>Only valid for IRBDP SW6 UI: Put cable grease on the process turning disc and the cable guide.</p>	<p>Cable grease 3HAC14807-1</p>

Continues on next page

4 Repair

4.2.5 Replacing the cable packages IRBDP SW6 UI and IRBDP MH6 UI LeanID

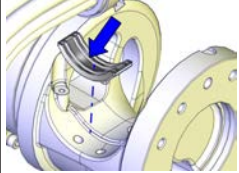
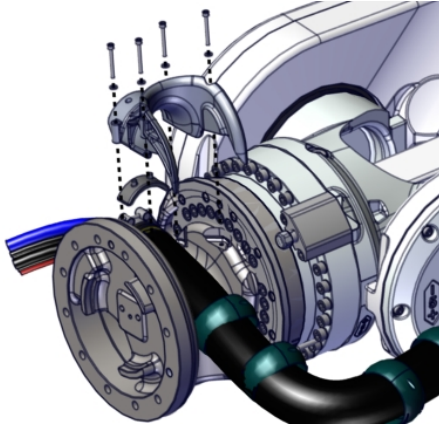
Continued

	Action	Note
7	<p>Only valid for IRBDP SW6 UI: Fasten the cable package in the clamp jaw with the process turning disc cable guide.</p>  <p>xx140000223</p>	 <p>xx1500002822</p>
8	<p> CAUTION</p> <p>Check potential collision risks between the cable package and the wrist, as well as between the cable package and any equipment fitted on the wrist, before restarting the normal production.</p>	
9	<p>Turn on the power and run the present programming at a very slow speed, while checking all movements for collision risk between cable package and wrist.</p>	
10	<p> DANGER</p> <p>Make sure all safety requirements are met when performing the first test run. See Test run after installation, maintenance, or repair on page 116.</p>	

4.2.6 Replacing the protection hose IRBDP SW6 UI and IRBDP MH6 UI LeanID

Location of protection hose, upper arm

The protection hose upper arm is located as shown in the figure.

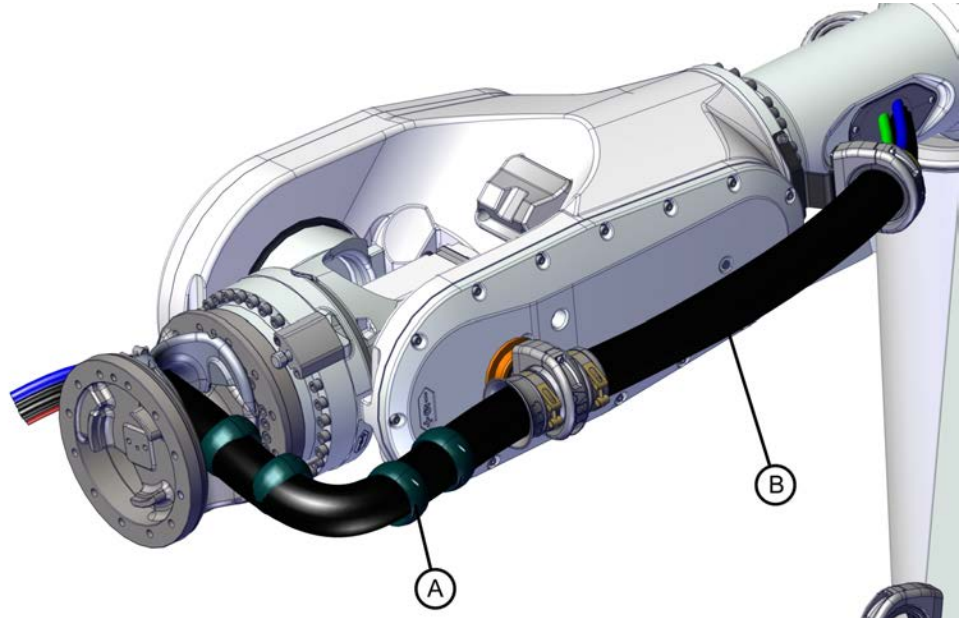

xx150003061

A	Protection hose, front part
B	Protection hose, back part

Spare parts

Wear parts	Article number	Note
Protection hose, upper arm, front part (1,150 mm)	See Wear parts on page 224	
Protection hose, upper arm, back part (745 mm)		

Required equipment

Equipment, etc.	Article number	Note
Standard toolkit	-	Content is defined in section Standard toolkit on page 213 .

Consumables

Equipment	Article number	Note
Cable grease	3HAC14807-1	Optitemp RB2

Continues on next page

4 Repair



4.2.6 Replacing the protection hose IRBDP SW6 UI and IRBDP MH6 UI LeanID

Continued

Removing the protection hose

Use these procedures to remove the protection hose

Remove cable guide

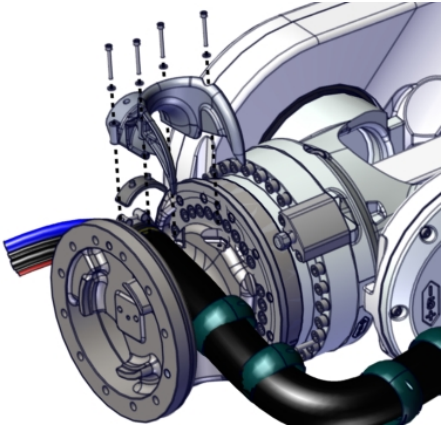
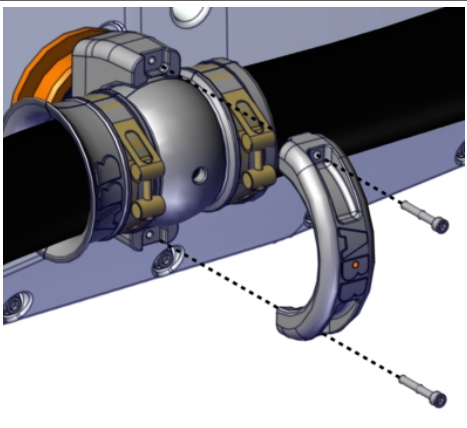
	Action	Note
1	Move the robot to a comfortable working position.	
2	 DANGER Turn off all: <ul style="list-style-type: none">• electric power supply• hydraulic pressure supply• air pressure supply to the robot, before entering the safeguarded space.	
3	 CAUTION The cable package is sensitive to mechanical damage. Handle it with care in order to avoid damaging the cabling or the connectors.	
4	Only valid for IRBDP SW6: Remove screws and washers to remove the cable guide.  Note There is cable grease in the turning disc cable guide.	 xx1500002822
5	Open the ball joint housing.	 xx1500002820

Continues on next page

4.2.6 Replacing the protection hose IRBDP SW6 UI and IRBDP MH6 UI LeanID
Continued

	Action	Note
6	 Note Let the cable package stay fitted in the second ball joint housing during the procedure.	

Remove the front part of the protection hose

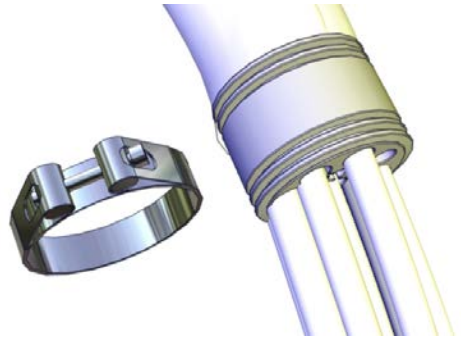
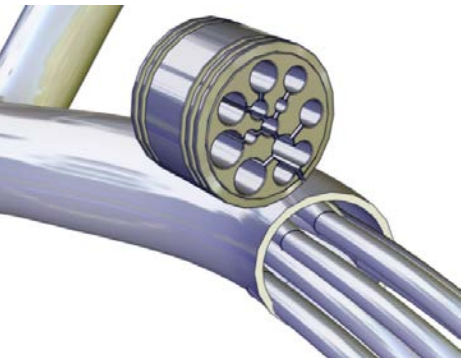
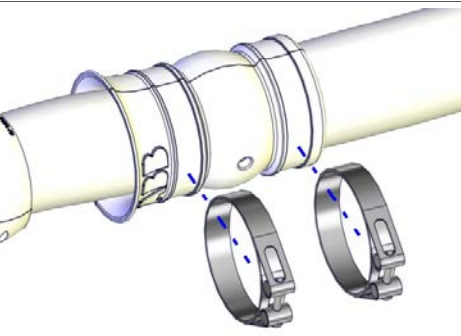

	Action	Note
1	Remove the hose clamp securing the cable and hose retainer.	 <p>xx1200000159</p>
2	Remove the cable and hose retainer.	 <p>xx1200000103</p>
3	Remove the hose clamps (2 pcs) securing the hose reinforcement funnel.	 <p>xx1400000209</p>

Continues on next page

4 Repair

4.2.6 Replacing the protection hose IRBDP SW6 UI and IRBDP MH6 UI LeanID

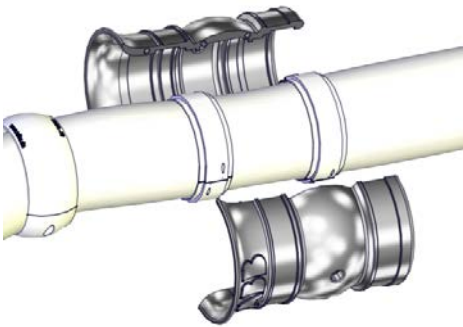
Continued

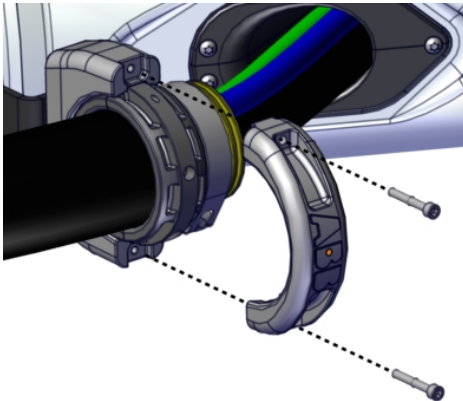

	Action	Note
4	Remove the hose reinforcement funnel (two parts).	 <p data-bbox="938 667 1046 685">xx140000210</p>
5	Carefully pull the cables and hoses out and remove the front part of the protection hose.  Tip The following order is preferred: <ol style="list-style-type: none"> 1 Cables with small connectors 2 Hoses 3 Cables with large connectors 	Best performed in this order: <ol style="list-style-type: none"> 1 Cables with the smallest connectors 2 Hoses 3 Cables with the biggest connectors.

Remove the back part protection hose

	Action	Note
1	Open the ball joint housing at the upper arm tube.	 <p data-bbox="938 1576 1046 1594">xx1500002819</p>

Continues on next page

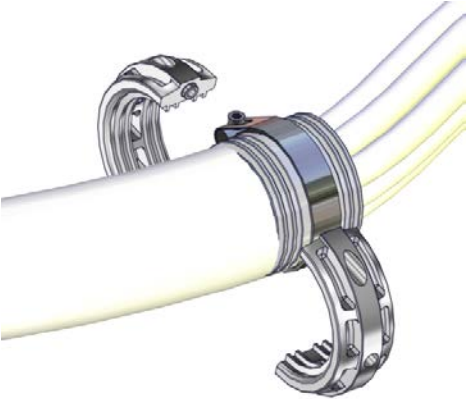
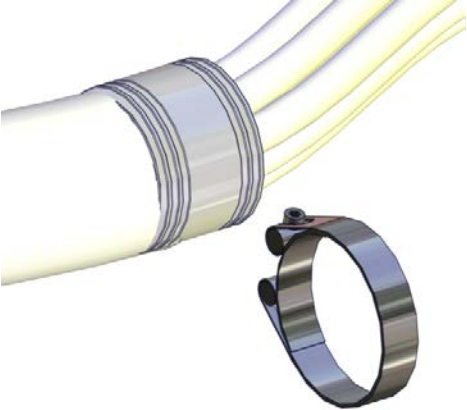
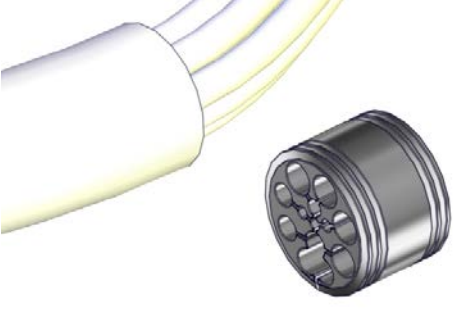
4.2.6 Replacing the protection hose IRBDP SW6 UI and IRBDP MH6 UI LeanID
Continued

	Action	Note
2	Remove the clamp jaw.	 <p>xx1400000347</p>
3	Open the hose clamps securing the cable and hose retainer.	 <p>xx1400000348</p>
4	Remove the cable and hose retainer.	 <p>xx1400000349</p>
5	<p>Carefully pull the cables and hoses out and remove the back part of the protection hose.</p> <p> Tip</p> <p>The following order is preferred:</p> <ol style="list-style-type: none"> 1 Cables with small connectors 2 Hoses 3 Cables with large connectors 	<p>Best performed in this order:</p> <ol style="list-style-type: none"> 1 Cables with the smallest connectors 2 Hoses 3 Cables with the biggest connectors.

Continues on next page

4 Repair





4.2.6 Replacing the protection hose IRBDP SW6 UI and IRBDP MH6 UI LeanID

Continued

Refitting the protection hose



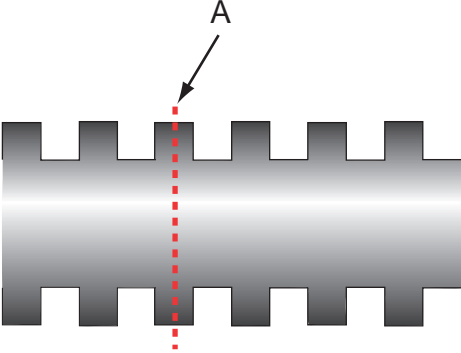

Use these procedures to refit the protection hose

Refitting the back part protection hose

	Action	Note
1	 <p>DANGER</p> <p>Turn off all:</p> <ul style="list-style-type: none"> • electric power supply • hydraulic pressure supply • air pressure supply <p>to the robot, before entering the safe-guarded space.</p>	
2	<p>Cut the new protection hose, back part to the length required.</p>  <p>Note</p> <p>Place the cut on top of a ridge.</p>	 <p>xx030000061</p> <p>Length: 745 mm</p>
3	<p>Put some cable grease on cables and hoses on the area where they run through the protection hose and hose reinforcement funnel.</p>	
4	<p>Carefully push cables and hoses into the protection hose.</p>  <p>Tip</p> <ol style="list-style-type: none"> 1 Cables with large connectors 2 Hoses 3 Cables with small connectors 	
5	<p>Make sure that cables and hoses are not twisted.</p>	

Continues on next page

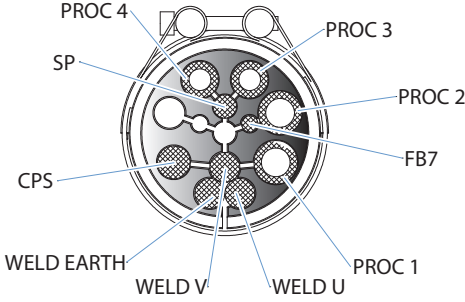
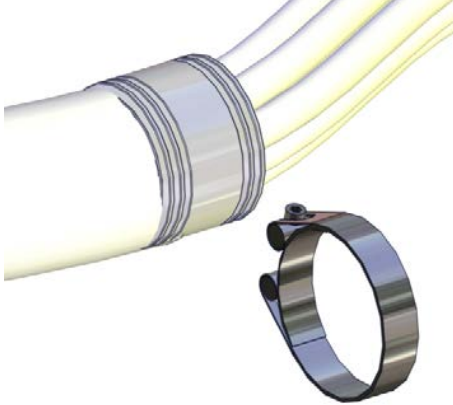
4.2.6 Replacing the protection hose IRBDP SW6 UI and IRBDP MH6 UI LeanID
Continued

	Action	Note
6	Fit the cable and hose retainer.	 <p>xx140000349</p>
7	Arrange the cables and hoses and put them in their position in the cable and hose retainer.  Note This is an example showing the Paracom cable harness. If in doubt check the positions on a cable and hose retainer that still is fitted.	 <p>xx120000106</p>
8	Secure the cable and hose retainer with the hose clamp.	 <p>xx140000348</p>
9	Fit the clamp jaw.	 <p>xx140000347</p>

Continues on next page



4 Repair

4.2.6 Replacing the protection hose IRBDP SW6 UI and IRBDP MH6 UI LeanID

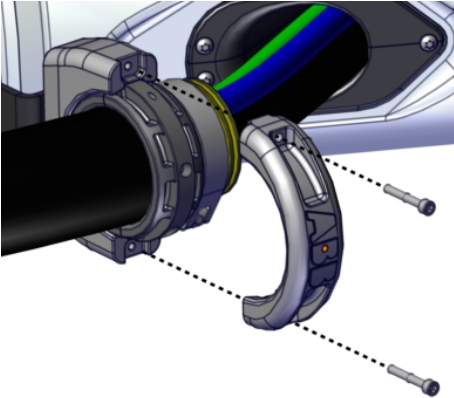
Continued

	Action	Note
10	Put the clamp jaw in the ball joint housing.	 <p data-bbox="943 745 1050 763">xx1500002819</p>

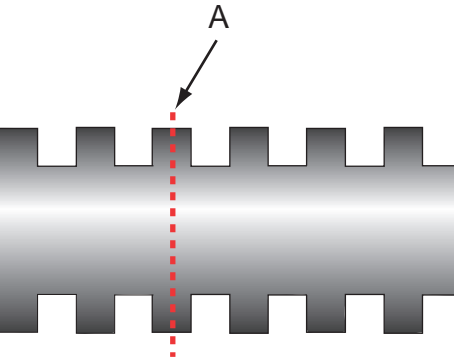
Refit the front part protection hose

	Action	Note
1	<p data-bbox="464 898 916 958">Cut the protection hose, front part, to the length required.</p> <p data-bbox="464 972 916 1077">  Note Place the cut on top of a ridge. </p>	 <p data-bbox="943 1267 1050 1285">xx0300000061</p> <p data-bbox="943 1296 1169 1326">Front end: 1,150 mm</p>
2	<p data-bbox="464 1348 916 1408">Carefully push cables and hoses into the protection hose.</p> <p data-bbox="464 1422 916 1603">  Tip 1 Cables with large connectors 2 Hoses 3 Cables with small connectors </p>	
3	<p data-bbox="464 1632 916 1680">Make sure that cables and hoses are not twisted.</p>	

Continues on next page

4.2.6 Replacing the protection hose IRBDP SW6 UI and IRBDP MH6 UI LeanID
Continued

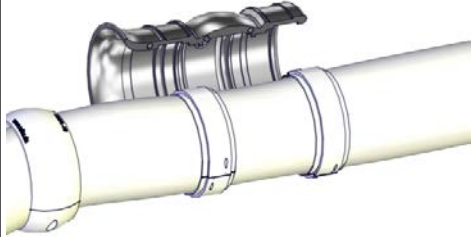
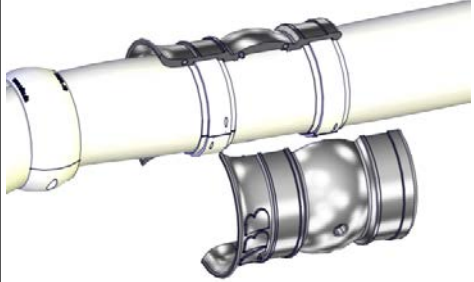
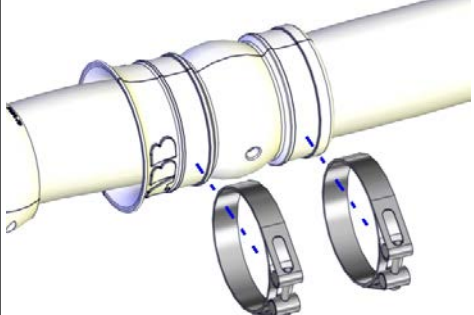
Action	Note
<p>4 Fit the middle jaws in one of the hose reinforcement funnel halves.</p> <p> Note</p> <p>The side of the hose reinforcement funnel which has the bigger outer diameter shall be turned towards the wrist.</p>	 <p>xx1400000350</p>
<p>5 Fit the other half of the funnel.</p>	 <p>xx1400000351</p>
<p>6 Fasten the hose reinforcement funnel with the hose clamps.</p>	 <p>xx1400000209</p>

Cable and hose retainer wrist

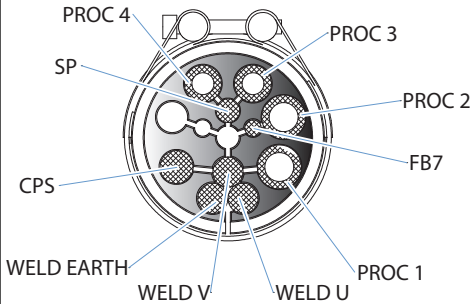
Action	Note
<p>1 Arrange cable and hoses according to their position in the cable and hose retainer.</p> <p> Note</p> <p>This is an example showing the Paracom cable harness. If in doubt check the positions on a cable and hose retainer that still is fitted.</p>	 <p>xx1200000106</p>

Continues on next page



4 Repair

4.2.6 Replacing the protection hose IRBDP SW6 UI and IRBDP MH6 UI LeanID

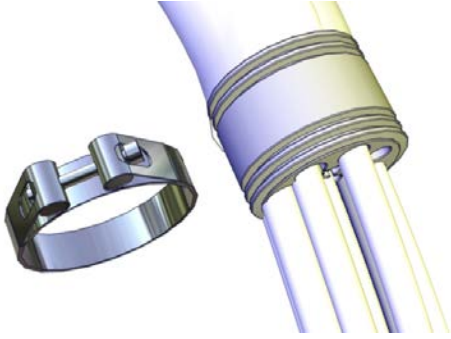
Continued

Action	Note
<p>2 Secure the cable and hose retainer with the hose clamp.</p>	 <p>xx1200000159</p>

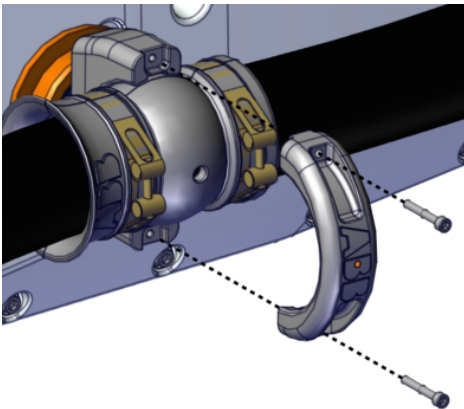
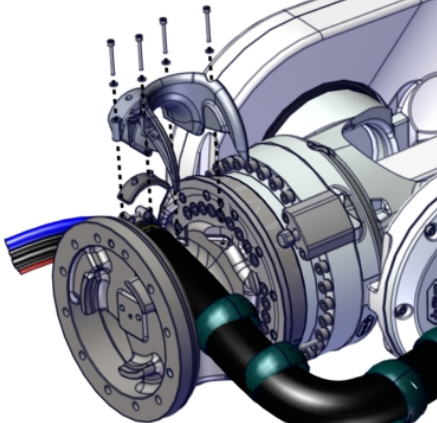
Refitting cable package

Action	Note
<p>1 Fasten the cable package in the ball joint housing.</p>	 <p>xx1500002820</p>
<p>2 Only valid for IRBDP SW6: Put some cable grease on the cable guide and the process turning disc.</p>	
<p>3 Only valid for IRBDP SW6: Fasten cable package with the cable guide.</p>	 <p>xx1500002822</p>
<p>4  DANGER Make sure all safety requirements are met when performing the first test run.</p>	

4.3 Water & Air unit

4.3.1 Replacement of Air supply circuit

Location of Water and air unit

The Water and air unit is located as shown in the figure.

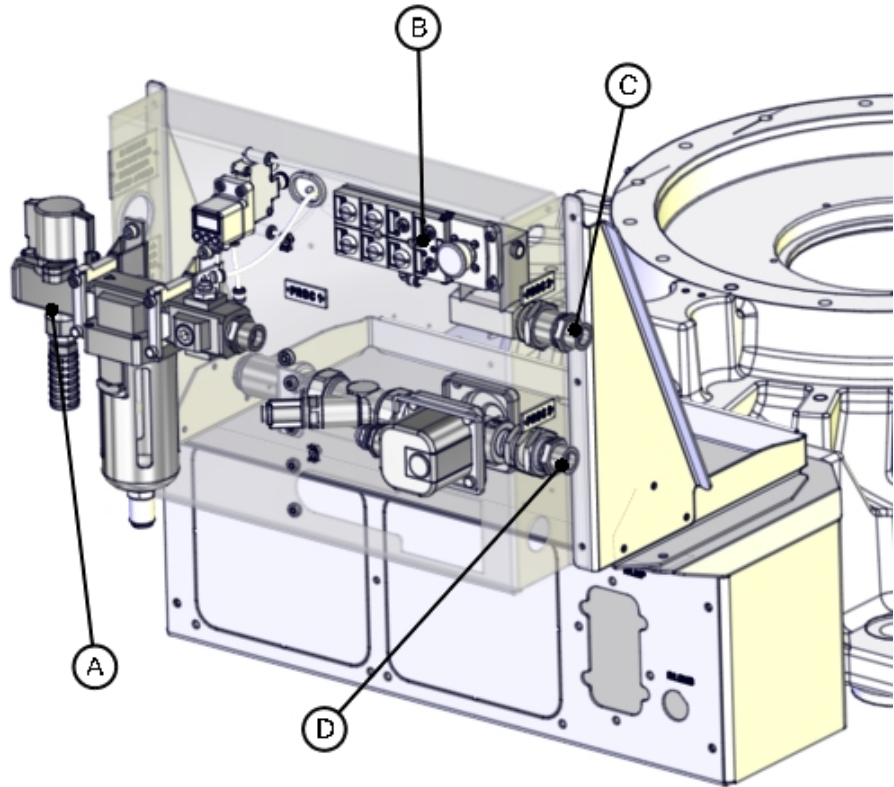

xx1300002328

A	Air supply circuit
B	Split box
C	Water in circuit
D	Water return circuit

Required equipment

Equipment	Art. no.	Note
Water and air unit	See <i>Spare parts</i> .	A number of versions are available. The Water and Air unit assembly contains all required hardware for fitting and connecting.
Standard toolkit, DressPack	3HAC17290-7	The contents are defined in section Toolkits, DressPack on page 213 .
Circuit diagram	3HAC026208-001	Dresspack for spotwelding

Continues on next page

4 Repair

4.3.1 Replacement of Air supply circuit

Continued

Removal

The procedure below details how to remove the Air supply circuit. It does not deal with details specific to each version, such as article numbers, connector types etc. For details see the *Spare parts* section.



	Action	Note
1	 CAUTION The system contains compressed air. Observe the safety information in section <i>Pneumatic or hydraulic related hazards on page 26</i> .	
2	Turn off the hand operated air valve on the air supply circuit.	The air hoses on the robot will be decompressed.
3	Turn off the shop floor air supply to the Water and Air unit.	
4	Remove the hose of the compressed air supply of the workshop.	
5	Remove the Proc 1 hose from the air supply unit.	
6	Remove the Proc 4 hose from the air supply unit.	Only if the option Proportional valve has been selected.
7	Disconnect the pressure switch tube from the Air circuit Cross interface.	
8	Disconnect the pressure switch connector on the split box, according to the circuit diagram.	
9	Disconnect the pressure switch from the mounting plate.	
10	If the option proportional valve is selected, disconnect the proportional valve connectors on the split box according to the circuit diagram.	
11	Unscrew the four attachment screws holding the air supply circuit and remove it.	

Refitting

The procedure below details how to refit the air supply circuit. It does not deal with details specific to each version, such as article numbers, connector types etc. For details see the *Spare parts* section.

	Action	Note
1	Fit the air supply circuit with its four attachment screws.	
2	Connect the proportional valve connectors on the split box according to the circuit diagram.	Only if the option Proportional valve has been selected.
3	Connect the pressure switch to the mounting plate.	
4	Connect the pressure switch connector on the split box according to the circuit diagram.	
5	Connect the pressure switch tube from the Air circuit Cross interface.	

Continues on next page

	Action	Note
6	Connect the Proc 4 hose from the Air supply unit.  CAUTION Do not tighten the brass couplings for water and air with excessive force.	Only if the option Proportional valve has been selected. Tightening torque: <ul style="list-style-type: none"> • Brass coupling 1/2": 31 Nm. • Stainless steel coupling 1/2": 49 Nm. • Brass coupling 3/8": 17 Nm. • Mixed metals: Use the lower tightening torque value of the two metals. Always apply Molykote P1900 to stainless steel couplings and apply if needed for couplings of mixed metals or brass.
7	Connect the Proc 1 hose from the Air supply unit.  CAUTION Do not tighten the brass couplings for water and air with excessive force.	Tightening torque: <ul style="list-style-type: none"> • Brass coupling 1/2": 31 Nm. • Stainless steel coupling 1/2": 49 Nm. • Brass coupling 3/8": 17 Nm. • Mixed metals: Use the lower tightening torque value of the two metals. Always apply Molykote P1900 to stainless steel couplings and apply if needed for couplings of mixed metals or brass.
8	Connect the hose of the compressed air supply of the workshop.	
9	Turn on the air supply to the Water and Air unit.	
10	Turn on the hand operated air valve on the air supply circuit.	The hoses at the robot will be compressed.
11	See if there are any leakages.	Tighten if there is leakage.

4 Repair

4.3.2 Replacement of Water-in circuit

4.3.2 Replacement of Water-in circuit

Location of Water-in circuit, type S

The water in circuit is located on the rear side of the Water and air unit as shown in the figure.

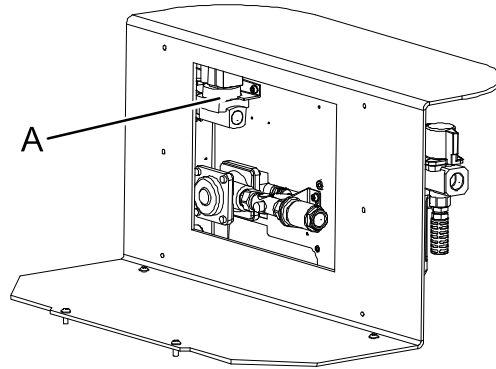

xx0600003462

A	Water-in circuit
---	------------------

Location of Water-in circuit, type Sb

The water in circuit is located on the rear side of the Water and air unit as shown in the figure.

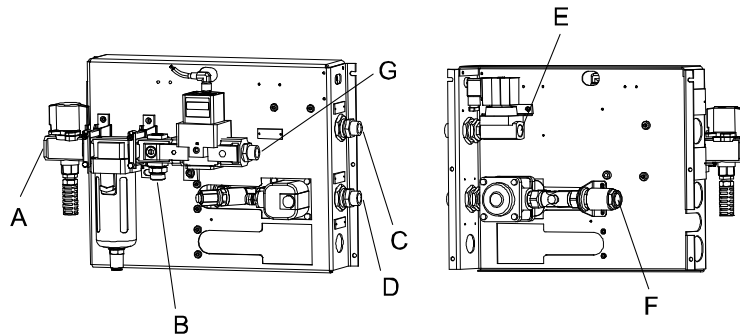

xx0800000122

A	Air supply circuit
B	PROC 1 on robot base
C	PROC 2 on robot base
D	PROC 3 on robot base
E	Water-in circuit
F	Water drain
G	PROC 4 on robot base (option)

Continues on next page

Required equipment

Equipment	Art. no.	Note
Water and Air unit	See <i>Spare parts</i> section!	A number of versions are available. The Water and Air unit assembly contains all required hardware for fitting and connecting.
Standard toolkit, DressPack	3HAC17290-7	The contents are defined in section Toolkits, DressPack on page 213 .
Circuit diagram	3HAC026208-001	Dresspack for spotwelding

Removal

The procedure below details how to remove the water-in circuit. It does not deal with details specific to each version, such as article numbers, connector types etc. For details see the *Spare parts* section.

	Action	Note
1	Turn off the water supply to the Water and Air unit.	
2	Remove the hose of the water supply of the workshop to the Water-in circuit.	
3	Remove the Proc 2 hose from the Water and Air unit.	
4	Remove the Pushlok nipple.	
5	Loosen the locking nut.	
6	Unscrew the two attachment screws holding the water-in circuit.	
7	Remove the Water-in circuit from the mounting plate.	
8	Remove the DIN-connector from the electrical water valve.	

Refitting

The procedure below details how to refit the water-in circuit. It does not deal with details specific to each version, such as article numbers, connector types etc. For details see the *Spare parts* section.

	Action	Note
1	Attach the DIN-connector to the electrical water valve.	
2	Fit the water-in circuit with its two attachment screws on the mounting plate.	
3	Tighten the locking nut.	
4	Fit the Pushlok nipple.	

Continues on next page

4 Repair

4.3.2 Replacement of Water-in circuit

Continued

	Action	Note
5	<p>Connect the Proc 2 hose on the Water and Air unit.</p> <p> CAUTION</p> <p>Do not tighten the brass couplings for water and air with excessive force.</p>	<p>Tightening torque:</p> <ul style="list-style-type: none">• Brass coupling 1/2": 31 Nm.• Stainless steel coupling 1/2": 49 Nm.• Brass coupling 3/8": 17 Nm.• Mixed metals: Use the lower tightening torque value of the two metals. <p>Always apply Molykote P1900 to stainless steel couplings and apply if needed for couplings of mixed metals or brass.</p>
6	Connect the hose of the workshop water supply to the Water-in circuit.	
7	Turn on the water supply to the Water and Air unit.	
8	Check for leakages.	Tighten if there are any leaks.

4.3.3 Replacement of Water-return circuit

Location of Water-return circuit, type S

The Water-return circuit (or circuits) is located on the rear side of the Water and air unit as shown in the figure.

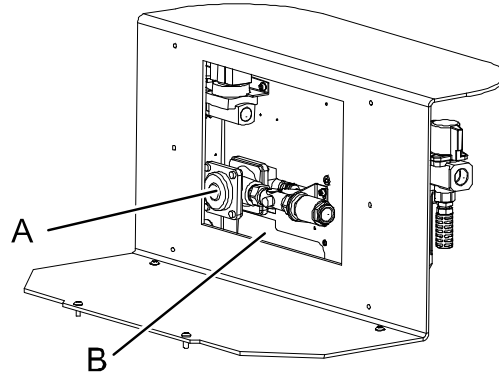

xx0600003464

A	Water-return circuit
B	Position for second Water-return circuit

Location of Water-return circuit, type Sb

The Water-return circuit (or circuits) is located on the rear side of the Water and air unit as shown in the figure.

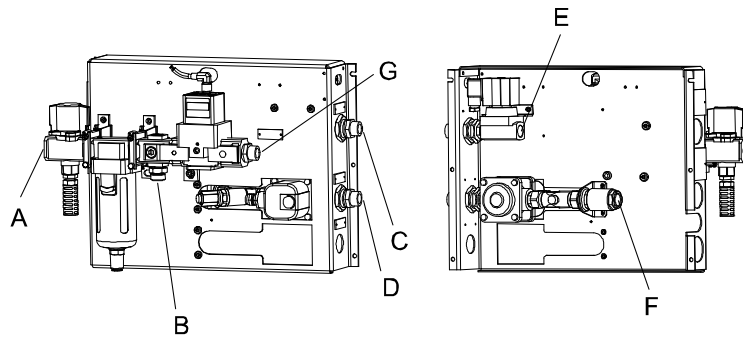

xx0800000122

A	Air supply circuit
B	PROC 1 on robot base
C	PROC 2 on robot base
D	PROC 3 on robot base
E	Water-in circuit
F	Water-return circuit
G	PROC 4 on robot base (option)

Continues on next page

4 Repair

4.3.3 Replacement of Water-return circuit

Continued

Required equipment

Equipment	Art. no	Note
Water and Air unit	See Spare Parts section.	A number of versions are available. The Water and Air unit assembly contains all required hardware for fitting and connecting.
Standard toolkit, DressPack	3HAC17290-7	The contents are defined in section Toolkits, DressPack on page 213 .
Circuit diagram	3HAC026208-001	Dresspack for spotwelding

Removal

The procedure below details how to remove the water-return circuit. It does not deal with details specific to each version, such as article numbers, connector types etc. For details see *Spare parts* section.



	Action	Note
1	Turn off the water supply to the Water and Air unit.	
2	Turn off the shop water drain from the Water and Air unit.	
3	Remove the hose of the shop floor water drain from the Water-return circuit.	One water-return: <ul style="list-style-type: none">• Disconnect the hose from the check valve Second water-return: <ul style="list-style-type: none">• Disconnect the hose from the bulkhead connector.
4	Loosen the locking nut.	Only if the option <i>Second water return</i> has been selected.
5	Remove the Proc 3 hose from the Water and Air unit.	
6	Remove the Proc 4 hose from the Water and Air unit.	Only if the option <i>Second water return</i> has been selected.
7	Remove the Pushlok nipple (or nipples) for return water.	
8	Loosen and remove the locking nut (or nuts).	
9	Unscrew the two attachment screws securing the mounting bracket (or brackets).	
10	Remove the Water-return circuit (or circuits) from the mounting plate.	

Refitting

The procedure below details how to refit the water-return circuit. It does not deal with details specific to each version, such as article numbers, connector types etc. For details see *Spare parts* section.

	Action	Note
1	Place the Water-return circuit (or circuits) on the mounting plate.	
2	Fit the two attachment screws securing the mounting bracket (or brackets).	

Continues on next page

	Action	Note
3	Fit and tighten the locking nut (or nuts).	
4	Fit the Pushlok nipple (or nipples).	
5	<p>Connect the Proc 3 hose from the Water and Air unit.</p> <p> CAUTION</p> <p>Do not tighten the brass couplings for water and air with excessive force.</p>	<p>Tightening torque:</p> <ul style="list-style-type: none"> • Brass coupling 1/2": 31 Nm. • Stainless steel coupling 1/2": 49 Nm. • Brass coupling 3/8": 17 Nm. • Mixed metals: Use the lower tightening torque value of the two metals. <p>Always apply Molykote P1900 to stainless steel couplings and apply if needed for couplings of mixed metals or brass.</p>
6	<p>Connect the Proc 4 hose from the Water and Air unit.</p> <p> CAUTION</p> <p>Do not tighten the brass couplings for water and air with excessive force.</p>	<p>Tightening torque:</p> <ul style="list-style-type: none"> • Brass coupling 1/2": 31 Nm. • Stainless steel coupling 1/2": 49 Nm. • Brass coupling 3/8": 17 Nm. • Mixed metals: Use the lower tightening torque value of the two metals. <p>Always apply Molykote P1900 to stainless steel couplings and apply if needed for couplings of mixed metals or brass.</p> <p>Only if the option <i>Second water return</i> has been selected.</p>
7	Tighten the locking nut, at the shop floor side.	Only if the option <i>Second water return</i> has been selected.
8	Connect the hose of the shop water drain to the water-return circuit.	
9	Turn on the water supply to the Water and Air unit.	
10	Activate the electrical valve.	
11	First turn on and then turn off the shop water drain.	This is done in order to evacuate all air in the circuit.
12	Wait a couple of minutes and check for leakage.	Tighten if there is any leakage.
13	Turn on the shop water drain.	

4 Repair

4.3.4 Replacement of Air filter element

4.3.4 Replacement of Air filter element

Replacement of air filter

Type S

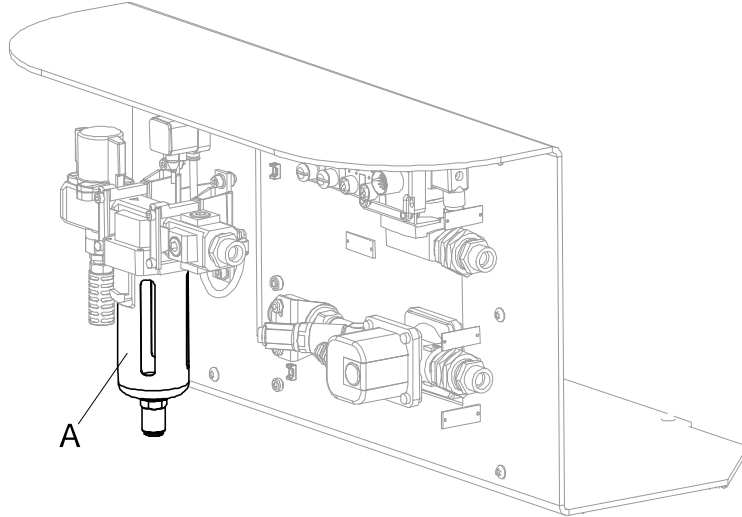

xx0700000400

A	Air filter
---	------------

Type Sb

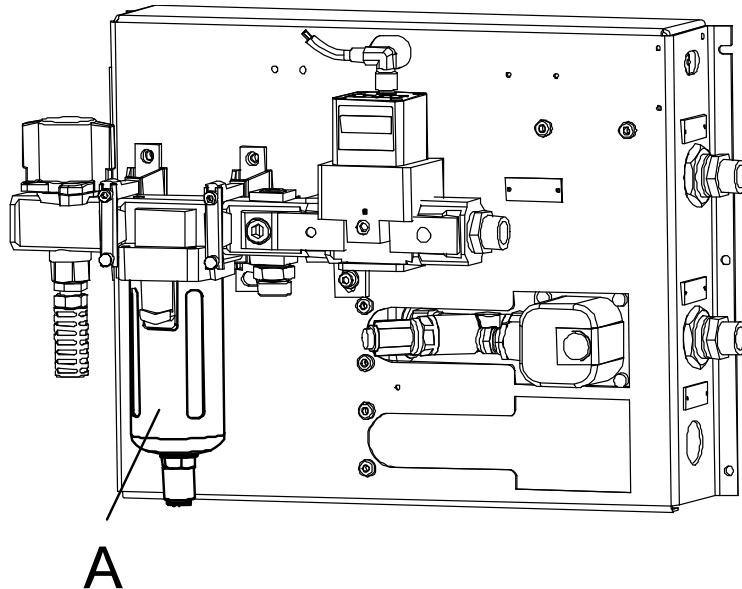

xx0800000125

A	Air filter
---	------------

Continues on next page

The procedure below details how to replace the air filter element on the Water and Air unit.

	Action	Note
1	Turn off the hand operated air valve and make sure that the air filter is not pressurized.	
2	Remove the bowl assembly, by following these steps: <ul style="list-style-type: none"> • Push the bowl assembly lock button. • Lift the bowl assembly. • Rotate the bowl assembly 45° (right or left). • Pull out the assembly. 	
3	Remove the baffle, filter element and deflector by rotating the baffle counterclockwise by hand.	
4	Fit the deflector to the body assembly. Mind the fitting direction of the deflector (concave in which the element goes into).	Deflector direction: Concave, facing the filter element.
5	Fit the new filter element by inserting it to the deflector concave.	
6	Fit the baffle by inserting it to the filter element. Mind the fitting direction of the baffle (convex to which the element goes).	Baffle direction: Convex, facing the filter element.
7	Tighten the baffle to settle the baffle, filter element and deflector by rotating the baffle counterclockwise until it contacts the element and deflector lightly. Rotate approximately one half revolution counterclockwise further in order to tighten them.	Tightening torque: 0.9 Nm
8	Fit the bowl assembly. Match the mating mark of the body and the bowl assembly to insert the assembly to the body. Rotate the assembly 45° (right or left) until the lock button is tossed up to fit the bowl assembly.	 Note Check that the lock button has tossed up!

This page is intentionally left blank

5 Decommissioning

5.1 Environmental information

Introduction

ABB robots contain components in different materials. During decommissioning, all materials shall be dismantled, recycled, or reused responsibly, according to the relevant laws and industrial standards. Robots or parts that can be reused or upcycled helps to reduce the usage of natural resources.

Disposal symbol

The following symbol indicates that the product must not be disposed of as common garbage. Handle each product according to local regulations for the respective content (see table below).

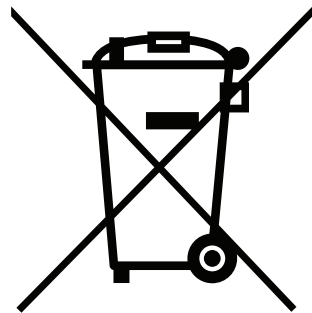

xx180000058

Materials used in the product

The table specifies some of the materials in the product and their respective use throughout the product.

Dispose components properly according to local regulations to prevent health or environmental hazards.

Material	Example application
Aluminium	Covers, synchronization brackets
Batteries, Lithium	Serial measurement board
Cast iron/nodular iron	Base, lower arm, upper arm
Copper	Cables, motors
Neodymium	Brakes, motors
Nickel	Turning disc (foundry)
Plastic/rubber	Cables, connectors, drive belts, and so on.
Steel	Gears, screws, base frame, and so on.

Continues on next page

5 Decommissioning

5.1 Environmental information

Continued

Oil and grease

Where possible, arrange for oil and grease to be recycled. Dispose of via an authorized person/contractor in accordance with local regulations. Do not dispose of oil and grease near lakes, ponds, ditches, down drains, or onto soil. Incineration must be carried out under controlled conditions in accordance with local regulations.

Also note that:

- Spills can form a film on water surfaces causing damage to organisms. Oxygen transfer could also be impaired.
- Spillage can penetrate the soil causing ground water contamination.

6 Reference information

6.1 Introduction

General

This chapter includes general information, complementing the more specific information in the different procedures in the manual.

6 Reference information

6.2 Unit conversion

6.2 Unit conversion

Converter table

Use the following table to convert units used in this manual.

Quantity	Units		
Length	1 m	3.28 ft.	39.37 in
Weight	1 kg	2.21 lb.	
Weight	1 g	0.035 ounces	
Pressure	1 bar	100 kPa	14.5 psi
Force	1 N	0.225 lbf	
Moment	1 Nm	0.738 lbf-ft	
Volume	1 L	0.264 US gal	

6.3 Screw joints

General

This section describes how to tighten the various types of screw joints on ABB robots.

The instructions and torque values are valid for screw joints comprised of metallic materials and do *not* apply to soft or brittle materials.

UNBRAKO screws

UNBRAKO is a special type of screw recommended by ABB for certain screw joints. It features special surface treatment (Gleitmo as described below) and is extremely resistant to fatigue.

Whenever used, this is specified in the instructions, and in such cases, *no other type of replacement screw* is allowed. Using other types of screws will void any warranty and may potentially cause serious damage or injury.

Gleitmo treated screws

Gleitmo is a special surface treatment to reduce the friction when tightening the screw joint. It is recommended by ABB for M6-M20 screw joints. Screws treated with Gleitmo may be reused 3-4 times before the coating disappears. After this the screw must be discarded and replaced with a new one.

When handling screws treated with Gleitmo, protective gloves of nitrile rubber type should be used.

Generally, screws are lubricated with *Gleitmo 603* mixed with *Geomet 500* or *Geomet 702* in proportion 1:3. *Geomet* thickness varies according to screw dimensions, refer to the following.

Dimension	Lubricant	Geomet thickness
M6-M20 (any length except M20x60)	<i>Gleitmo 603 + Geomet 500</i>	3-5 µm
M6-M20 (any length except M20x60)	<i>Gleitmo 603 + Geomet 720</i>	3-5 µm
M20x60	<i>Gleitmo 603 + Geomet 500</i>	8-12 µm
M20x60	<i>Gleitmo 603 + Geomet 720</i>	6-10 µm

Screws lubricated in other ways

Screws lubricated with Molykote 1000 or Molykote P1900 should *only* be used when specified in the repair, maintenance or installation procedure descriptions.

In such cases, proceed as follows:

- 1 Apply lubricant to the screw thread.
- 2 Apply lubricant between the plain washer and screw head.
- 3 Screw dimensions of M8 or larger must be tightened with a torque wrench. Screw dimensions of M6 or smaller may be tightened without a torque wrench *if* this is done by trained and qualified personnel.

Continues on next page

6 Reference information

6.3 Screw joints

Continued

Lubricant	Article number
Molykote 1000 (molybdenum disulphide grease)	3HAC042472-001
Molykote P1900 (molybdenum disulphide grease)	3HAC070875-001

Tightening torque

Before tightening any screw, note the following:

- Determine whether a **standard** tightening torque or **special** torque is to be applied. The **standard torques** are specified in the following tables. Any **special torques** are specified in the repair, maintenance or installation procedure descriptions. **Any special torque specified overrides the standard torque!**
- Use the *correct tightening torque* for each type of screw joint.
- Only use *correctly calibrated* torque keys.
- *Always tighten the joint by hand*, and never use pneumatic tools.
- Use the *correct tightening technique*, that is *do not* jerk. Tighten the screw in a slow, flowing motion.
- Maximum allowed total deviation from the specified value is **10%!**

Tightening torque for oil-lubricated screws with slotted or cross-recess head screws

The following table specifies the recommended standard tightening torque for *oil-lubricated screws with slotted or cross-recess head screws*.



Note

A special torque specified in the repair, maintenance or installation procedure overrides the standard torque.

Tightening torque for oil-lubricated screws with allen head screws

The following table specifies the recommended standard tightening torque for *oil-lubricated screws with allen head screws*.



Note

A special torque specified in the repair, maintenance or installation procedure overrides the standard torque.

Dimension	Tightening torque (Nm)	Tightening torque (Nm)	Tightening torque (Nm)
	Class 8.8, oil-lubricated	Class 10.9, oil-lubricated	Class 12.9, oil-lubricated
M5	6	-	-
M6	10	-	-
M8	24	34	40
M10	47	67	80
M12	82	115	140
M16	200	290	340
M20	400	560	670

Continues on next page

Dimension	Tightening torque (Nm) Class 8.8, oil-lubricated	Tightening torque (Nm) Class 10.9, oil-lubricated	Tightening torque (Nm) Class 12.9, oil-lubricated
M24	680	960	1150

Tightening torque for lubricated screws (Molykote, Gleitmo or equivalent) with allen head screws
The following table specifies the recommended standard tightening torque for *screws lubricated with Molykote 1000, Gleitmo 603 or equivalent with allen head screws.*

**Note**

A special torque specified in the repair, maintenance or installation procedure overrides the standard torque.

Dimension	Tightening torque (Nm) Class 10.9, lubricated ⁱ	Tightening torque (Nm) Class 12.9, lubricated ⁱ
M5		8
M6		14
M8	28	35
M10	55	70
M12	96	120
M16	235	300
M20	460	550
M24	790	950

ⁱ Lubricated with Molykote 1000, Gleitmo 603 or equivalent

Water and air connectors

The following table specifies the recommended standard tightening torque for *water and air connectors.*

**Note**

A special torque specified in the repair, maintenance or installation procedure overrides the standard torque.

Dimension	Material	Tightening torque Nm - Nominal	Tightening torque Nm - Min.	Tightening torque Nm - Max.
ALL	Mixed	The lower tightening torque of the two materials.		
1/8	Brass only	12	8	15
1/4	Brass only	15	10	20
3/8	Brass only	20	15	25
1/2	Brass only	40	30	50
1/2	Stainless steel only	49	47	59
3/4	Brass only	70	55	90

6 Reference information

6.4 Weight specifications

6.4 Weight specifications

Definition

In installation, repair, and maintenance procedures, weights of the components handled are sometimes specified. All components exceeding 22 kg (50 lbs) are highlighted in this way.

To avoid injury, ABB recommends the use of a lifting accessory when handling components with a weight exceeding 22 kg. A wide range of lifting accessories and devices are available for each manipulator model.

Example

Following is an example of a weight specification in a procedure:

	Action	Note
	 CAUTION The arm weighs 25 kg. All lifting accessories used must be sized accordingly.	

6.5 Toolkits, DressPack

General

All service (repair, maintenance and installation) instructions contain lists of tools required to perform the specified activity. All special tools, that is all tools that are not considered standard as defined below, are listed in their instructions respectively.

This way, the tools required are the sum of the Standard Toolkit and any tools listed in the instruction.

Standard toolkit

This standard toolkit contains a set of standard tools used for DressPack, 3HAC17290-7.

Qty	Article number	Tool	Note
1	-	Socket head cap, 5-17mm	-
1	-	Torx socket no: 20-60	-
1	-	Phillips screwdriver, small	For Harting connectors
1	-	Flat screwdriver, medium	For Harting connectors
2	-	Ring-open-end spanner 8-19 mm	For water connectors on water and air unit
1	-	Open end wrench, 27 mm.	For Tension arm unit and water connectors on DressPack
1	-	Open end wrench, 36 mm	For water connectors on DressPack

Toolkit, cables

This toolkit contains tools needed for work with cables:

Qty	Article number	Tool	Note
1	0999 000 0171 (D-sub)	Removal and Insertion tool for pins and sockets	Art. no. from Harting
1	0999 000 0012 (HAN DD)	Removal tool for pins and sockets	Art. no. from Harting
1	0999 000 0319 (HAN EE)	Removal tool for pins and sockets	Art. no. from Harting
1	0999 000 0059 (HAN DD and HAN EE)	Insertion tool for pins and sockets	Art. no. from Harting
1	-	Stripping pliers	
1	09 99 000 0021	Crimping tool HARTING with locator	Art. no. from Harting
1	09 99 000 0001	Crimping tool BUCHANAN, HARTING	Art. no. from Harting
1	09 99 000 0175 09 99 000 0169	Crimping tool HARTING	Art. no. from Harting

Continues on next page

6 Reference information

6.5 Toolkits, DressPack

Continued

Qty	Article number	Tool	Note
1	M12 torque screwdriver and M12 assembly tool (bit)	<p>TSD 04 SAC (article number at Phoenix Contact)</p> <p>SAC BIT M12-D15 (article number at Phoenix Contact)</p>  <p>xx2200001262</p>	<p>Order both parts and assemble.</p> <p>The screwdriver has a preset torque of 0.4 Nm.</p> <p>Used to tighten M12 Ethernet connectors.</p>

6.6 Lifting accessories and lifting instructions

General

Many repair and maintenance activities require different pieces of lifting accessories, which are specified in each procedure.

The use of each piece of lifting accessories is *not* detailed in the activity procedure, but in the instruction delivered with each piece of lifting accessories.

The instructions delivered with the lifting accessories should be stored for later reference.

This page is intentionally left blank

7 Spare parts

7.1 Introduction

General

This chapter contains more specific article information. It is to be regarded as a complement to the slightly generic procedure information found in the Installation, Maintenance and Repair chapters.

The robot system itself, consisting of robot and controller cabinet, is described in its own technical documents.

7 Spare parts

7.2 DressPack cable package IRBDP SW6 LI

7.2 DressPack cable package IRBDP SW6 LI

General

This chapter contains more specific article information. It is to be regarded as a complement to the slightly generic procedure information found in the Installation, Maintenance and Repair chapters.

The robot system itself, consisting of robot and controller cabinet, is detailed in its own technical documents.

IRBDP SW6 LI

This section describes the spare parts for DressPack cable package IRBDP SW6 LI.

Spare part number	800/3.50	550/4.20
3HAC055113-001 Paracom	X	X
3HAC055113-002 Paracom Servo Gun	X	X
3HAC055114-001 Parabus Com	X	X
3HAC055114-002 Parabus Com Servo Gun	X	X
3HAC055115-001 Paramulti	X	X
3HAC055115-002 Paramulti Servo Gun	X	X

7.3 DressPack cable package IRBDP SW6 UI

General

This chapter contains more specific article information. It is to be regarded as a complement to the slightly generic procedure information found in the Installation, Maintenance and Repair chapters.

The robot system itself, consisting of robot and controller cabinet, is detailed in its own technical documents.

IRBDP SW6 UI

This section describes the spare parts for DressPack cable package IRBDP SW6 UI.

Spare part number	800/3.50	550/4.20
3HAC055584-001 Paracom	X	
3HAC055584-002 Paracom Long		X
3HAC055584-004 Paracom Servo Gun	X	
3HAC055584-006 Paracom Servo Gun Long		X
3HAC055585-001 Parabus com	X	
3HAC055585-002 Parabus com Long		X
3HAC055585-003 Parabus com Servo Gun	X	
3HAC055585-004 Parabus Com Servo Gun Long		X
3HAC055586-001 Paramulti	X	
3HAC055586-002 Paramulti Long		X
3HAC055586-003 Paramulti Servo Gun	X	
3HAC055586-004 Paramulti Servo Gun Long		X

7 Spare parts

7.4 DressPack cable package IRBDP MH3 UI

7.4 DressPack cable package IRBDP MH3 UI

General

This chapter contains more specific article information. It is to be regarded as a complement to the slightly generic procedure information found in the Installation, Maintenance and Repair chapters.

The robot system itself, consisting of robot and controller cabinet, is detailed in its own technical documents.

IRBDP MH3 UI

This section describes the spare parts for DressPack cable package IRBDP MH3 UI.

Spare part number	800/3.50	550/4.20
3HAC055588-001 Paracom	X	
3HAC055588-002 Paracom Long		X
3HAC055589-001 Parabus Com	X	
3HAC055589-002 Parabus Com Long		X
3HAC055590-001 Paramulti	X	
3HAC055590-002 Paramulti Long		X

7.5 DressPack cable package IRBDP MH LI

General

This chapter contains more specific article information. It is to be regarded as a complement to the slightly generic procedure information found in the Installation, Maintenance and Repair chapters.

The robot system itself, consisting of robot and controller cabinet, is detailed in its own technical documents.

IRBDP MH LI

This section describes the spare parts for DressPack cable package IRBDP MH6 LI.

Spare part number	800/3.50	550/4.20
3HAC052425-001 Paracom	X	X
3HAC052426-001 Parabus com	X	X
3HAC052427-001 Paramulti	X	X

7 Spare parts

7.6 DressPack cable package IRBDP MH6 UI

7.6 DressPack cable package IRBDP MH6 UI

General

This chapter contains more specific article information. It is to be regarded as a complement to the slightly generic procedure information found in the Installation, Maintenance and Repair chapters.

The robot system itself, consisting of robot and controller cabinet, is detailed in its own technical documents.

IRBDP MH6 UI

This section describes the spare parts for DressPack cable package IRBDP MH6 UI.

Spare part number	800/3.50	550/4.20
3HAC054634-001 Paracom	X	
3HAC054634-003 Paracom Long		X
3HAC054635-001 Parabus Com	X	
3HAC054635-002 Parabus Com Long		X
3HAC054636-001 Paramulti	X	
3HAC054636-002 Paramulti Long		X

7.7 Sub cables

Spare parts

This section describes the spare parts for DressPack Sub cables.

Spare part number	800/3.50	550/4.20
3HAC054648-001 CPS axes 3-6	X	
3HAC054801-001 CPS axes 3-6 Long		X
3HAC055620-001 SP axes 3-6	X	
3HAC055621-001 SP axes 3-6 Long		X
3HAC055618-001 FB axes 3-6	X	
3HAC055619-001 FB axes 3-6 Long		X
3HAC054650-001 CBUS axes 3-6	X	
3HAC054802-001 CBUS axes 3-6 Long		X
3HAC054654-001 Ethernet Upper arm	X	
3HAC054803-001 Ethernet Upper arm, long		X

7 Spare parts

7.8 Wear parts

7.8 Wear parts

Wear parts

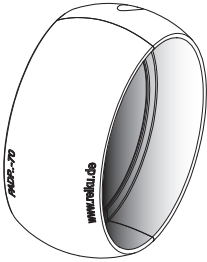
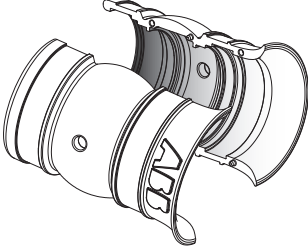
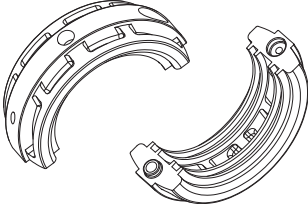
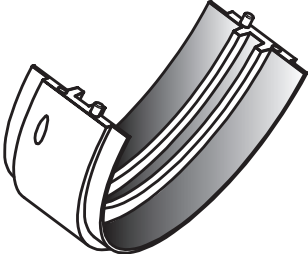
Spare part number	Illustration	Note
3HAC5320-2 Protection hose Lower arm		Only delivered in full meters.
3HAC042173-004 Protection hose Upper arm, back part (745 mm)		This length is ready to use.
3HAC042173-005 Protection hose Upper arm, front part (1,150 mm)		This length is ready to use.
3HAC032660-001 Protective sleeve, rotary	 xx1400001981	Delivered complete (both parts).
3HAC032916-001 Hose reinforcement funnel	 xx1400001982	Delivered complete (both parts).
3HAC042483-001 Clamp insert	 xx1400001400	Delivered complete (both parts).
3HAC14290-1 Middle jaw	 xx1400001399	Delivered complete (both parts).

Continues on next page

7 Spare parts

7.8 Wear parts

Continued

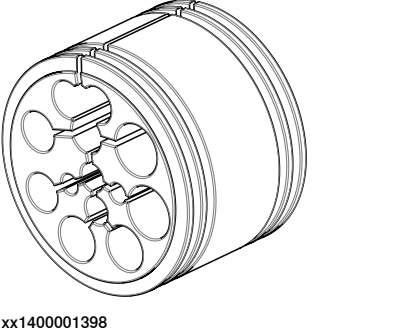
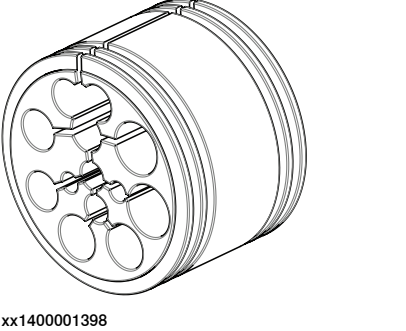
Spare part number	Illustration	Note
3HAC035251-001 Cable & hose retainer 60	 <p>xx1400001398</p>	
3HAC035251-002 Cable & hose retainer 40	 <p>xx1400001398</p>	

7 Spare parts

7.9 Connection kits

7.9 Connection kits

General

This chapter contains more specific article information. It is to be regarded as a complement to the slightly generic procedure information found in the Installation, Maintenance and Repair chapters.

The robot system itself, consisting of robot and controller cabinet, is detailed in its own technical documents.

Spare parts

Spare part	Spare part number	Note
CP/CS Proc 1 on base	3HAC16667-1	
Weld, Proc axis 6	3HAC043502-001	
CP/CS/CBUS Ethernet, Proc axis 3	3HAC048464-001	
CP/CS/CBUS Ethernet, Proc axis 6	3HAC043503-001	
7th axis on base	3HAC023441-001	

7.10 7th axis to base

General

This chapter contains more specific article information. It is to be regarded as a complement to the slightly generic procedure information found in the Installation, Maintenance and Repair chapters.

The robot system itself, consisting of robot and controller cabinet, is detailed in its own technical documents.

Spare parts

Spare part	Spare part number	Note
7th axis, serial cable	3HAC023278-001	

7 Spare parts

7.11 DressPack floor

7.11 DressPack floor

Spare parts

Spare part	Spare part number	Note
Floor weld cable	3HAC16847-1	7 m 3x35 mm ² MC connector
Floor weld cable	3HAC16847-2	15 m 3x35 mm ² MC connector
Floor weld cable	3HAC16847-4	22 m 3x35 mm ² MC connector
Cable to split box	3HAC16844-1	7 m Used with Water and air unit
Cable to split box	3HAC16844-2	15 m Used with Water and air unit
Cable to split box	3HAC16844-13	22 m Used with Water and air unit
Cable to split box	3HAC16844-3	30 m Used with Water and air unit
Process cable to stat gun	3HAC025117-001	7 m
Process cable to stat gun	3HAC025117-002	15 m
Process cable to stat gun	3HAC025117-003	22 m
Process cable to stat gun	3HAC025117-006	30 m

7.12 Customer signal/power

General

This chapter contains more specific article information. It is to be regarded as a complement to the slightly generic procedure information found in the Installation, Maintenance and Repair chapters.

The robot system itself, consisting of robot and controller cabinet, is detailed in its own technical documents.

Spare parts

Spare part	Spare part number	Note
Harness - CP/CS/DeviceNet	3HAC022978-001	7 m Parallel DeviceNet
	3HAC022978-002	15 m Parallel DeviceNet
	3HAC022978-006	22 m Parallel DeviceNet
	3HAC022978-003	30 m Parallel DeviceNet
Harness - CP/CS/ProfiBus ⁱ	3HAC022988-001	7 m ProfiBus
	3HAC022988-002	15 m ProfiBus
	3HAC022988-006	22 m ProfiBus
	3HAC022988-003	30 m ProfiBus
Harness - CP/CS CC-Link ⁱⁱ EtherCat ⁱⁱ	3HAC022957-001	7 m Parallel
	3HAC022957-002	15 m Parallel
	3HAC022957-006	22 m Parallel
	3HAC022957-003	30 m Parallel
Harness - Profinet	3HAC031924-001	7 m
	3HAC031924-002	15 m
	3HAC031924-003	22 m
	3HAC031924-004	30 m

Continues on next page

7 Spare parts

7.12 Customer signal/power

Continued

Spare part	Spare part number	Note
Ethernet cable ⁱⁱ	3HAC079476-001	7 m
CC-Link	3HAC079476-002	15 m
EtherCat	3HAC079476-003	22 m
	3HAC079476-004	30 m

ⁱ Only valid for IRC5.

ⁱⁱ Only valid for OmniCore.

7.13 Water and air unit**Spare parts**

This section details spare parts for the water and air unit.

Spare part	Spare part number	Note
Water and air unit	3HAC027294-001	Basic Type S
Water and air unit	3HAC027294-002	2:nd water return
Water and air unit	3HAC027294-003	E/P valve Type S

Continues on next page

7 Spare parts

7.13.1 DressPack - Water and air unit

7.13.1 DressPack - Water and air unit

Overview

The following section details spare parts for DressPack Water and air unit.

Water and air unit

Parts	Article no.	Note
Water and air unit	3HAC048636-001	Basic
Water and air unit	3HAC048636-002	2:nd water return
Water and air unit	3HAC048636-003	E/P valve

Hoses for Water and air unit

Parts	Article number	Note
Air hose if E/P valve	3HAC16845-2	Orange
Air hose if E/P valve	3HAC16845-4	Black
Hose water and air unit (3 pcs)	3HAC16845-1	Orange
Hose water and air unit (3 pcs)	3HAC16845-5	Black

8 Circuit diagrams

8.1 Circuit diagrams

Overview

The circuit diagrams are not included in this manual, but are available for registered users on myABB Business Portal, www.abb.com/myABB.

See the article numbers in the tables below.

Controllers

Product	Article numbers for circuit diagrams
<i>Circuit diagram - IRC5</i>	<i>3HAC024480-011</i>

DressPack

Product	Article numbers for circuit diagrams
<i>Circuit diagram - DressPack IRB 5710 / IRB 5720</i>	<i>3HAC081433-001</i>
<i>Circuit diagram - DressPack 6650S/7600 LeanID</i>	<i>3HAC022327-002</i>
<i>Circuit diagram - DressPack 6650S/7600</i>	<i>3HAC026209-001</i>
<i>Circuit diagram - DressPack 6620</i>	<i>3HAC026136-001</i>
<i>Circuit diagram - DressPack IRB 6640, IRB 6650S, IRB 7600</i>	<i>3HAC026209-001</i>
<i>Circuit diagram - DressPack 6660</i>	<i>3HAC029940-001</i>
<i>Circuit diagram - DressPack 6700</i>	<i>3HAC044246-002</i>
<i>Circuit diagram - DressPack IRB 6710 / IRB 6720 / IRB 6730 / IRB 6740</i>	<i>3HAC087933-001</i>
<i>Circuit diagram - DressPack 8700</i>	<i>3HAC053524-002</i>
<i>Circuit diagram - DressPack for spotwelding SWC IRC5 M2004</i>	<i>3HAC026208-001</i>
<i>Circuit diagram - DressPack SWC IRC5 Design 2014 PROFINET</i>	<i>3HAC044736-001</i>

This page is intentionally left blank

Index

A

allergenic material, 25
aluminum
 disposal, 205
assessment of hazards and risks, 25

B

batteries
 disposal, 205

C

cabinet lock, 25
carbon dioxide extinguisher, 26
cast iron
 disposal, 205
climbing on robot, 28
copper
 disposal, 205

E

environmental information, 205

F

fire extinguishing, 26
functional ground, 136

G

grease, 28
grounding, 136

H

hanging
 installed hanging, 25
hazard levels, 17
hazardous material, 205
height
 installed at a height, 25
hot surfaces, 28
HRA, 25

I

integrator responsibility, 25

L

labels
 robot, 18
lifting accessory, 212
limitation of liability, 15
Lithium
 disposal, 205
lock and tag, 25
lubricants, 28

M

magnesium
 disposal, 205

N

national regulations, 25
neodymium
 disposal, 205
nodular iron

disposal, 205

O

oil, 28
original spare parts, 15

P

pedestal
 installed on pedestal, 25
personnel
 requirements, 16
plastic
 disposal, 205
PPE, 16
protective equipment, 16
protective wear, 16

R

recycling, 205
regional regulations, 25
replacements, report, 135
report replacements, 135
responsibility and validity, 15
risk of burns, 28
robot
 labels, 18
 symbols, 18
rubber
 disposal, 205

S

safety
 fire extinguishing, 26
 signals, 17
 signals in manual, 17
 symbols, 17
 symbols on robot, 18
 test run, 116
safety devices, 26
safety hazard
 hydraulic system, 26
 pneumatic system, 26
safety signals
 in manual, 17
screw joints, 209
signals
 safety, 17
steel
 disposal, 205
symbols
 safety, 17
system integrator requirements, 25

T

troubleshooting
 safety, 31

U

upcycling, 205
users
 requirements, 16

V

validity and responsibility, 15



ABB AB

Robotics & Discrete Automation

S-721 68 VÄSTERÅS, Sweden

Telephone +46 10-732 50 00

ABB AS

Robotics & Discrete Automation

Nordlysvegen 7, N-4340 BRYNE, Norway

Box 265, N-4349 BRYNE, Norway

Telephone: +47 22 87 2000

ABB Engineering (Shanghai) Ltd.

Robotics & Discrete Automation

No. 4528 Kangxin Highway

PuDong New District

SHANGHAI 201319, China

Telephone: +86 21 6105 6666

ABB Inc.

Robotics & Discrete Automation

1250 Brown Road

Auburn Hills, MI 48326

USA

Telephone: +1 248 391 9000

abb.com/robotics